

2D Color Analyzer CA-2000 Series

Instruction Manual

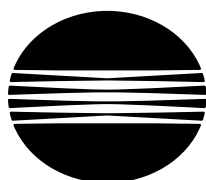

KONICA MINOLTA

Safety Symbols

The following symbols are used in this manual to prevent accidents which may occur as a result of incorrect use of the instrument.



Denotes a sentence regarding safety warning or precaution.
Read the sentence carefully to ensure safe and correct use.



Denotes a prohibited operation.
The operation must never be performed.



Denotes an instruction.
The instruction must be strictly adhered to.



Denotes an instruction.
Disconnect AC adapter from AC outlet.













Denotes a prohibited operation.
Never disassemble this instrument.



Notes on this manual

- Copying or reproduction of all or any part of the contents of this manual without KONICA MINOLTA SENSING's permission is strictly prohibited.
- Contents of this manual are subject to change without prior notice.
- Every effort has been made in the preparation for this manual to ensure the accuracy of its contents. However, should you have any questions or find any errors, contact the nearest KONICA MINOLTA SENSING authorized service facility.
- KONICA MINOLTA SENSING will not accept any responsibility for consequences arising from the use of this instrument.

Safety Warnings and Cautions

To ensure correct use of this instrument, read the following points carefully and adhere to them. After you have read this manual, keep it in a safe place where it can be referred to anytime a question arises.

	Warning (Failure to adhere to the following points may result in death or serious injury.)
	Do not use this instrument in places where flammable or combustible gases (gasoline etc.) are present. Doing so may cause fire.
	Always use the AC adapter and power cord supplied as a standard accessory or optional (AC-A22), and connect it to indoor AC outlet of rated voltage 100 V-240 V ~ and frequency 50 Hz-60 Hz. Failure to follow either of these may result in damage to instrument or AC adapter, fire or electric shock.
	If this instrument is not used for a long time, disconnect AC adapter from AC outlet. Accumulated dirt or water on prongs of AC adapter plug may cause fire. Be sure to remove before use.
	Do not forcibly pull any part on power cord when unplugging since this may damage power cord, resulting in fire or electric shock. Gently disconnect by holding plug. Also, do not handle power plug with wet hands. Doing so may cause electric shock.
	Dust could enter inside this instrument from air duct. Do not leave such dust accumulated while using for this may cause fire. Contact with the nearest KONICA MINOLTA SENSING authorized service facility for periodical checkup.
	Do not forcibly bend, twist or pull power cord. Also, do not place heavy object on power cord, or damage or modify one. Any of these may cause fire or electric shock due to damage to power cord.
	Do not disassemble or modify this instrument or AC adapter. Doing so may cause fire or electric shock.
	Do not expose this instrument to liquid or metal object which may cause fire or electric shock. Should either of these happen, switch power off immediately, unplug AC adapter, and contact the nearest KONICA MINOLTA SENSING authorized service facility.
	Should this instrument or AC adapter be damaged or smoke or odd smell be generated, do not keep using one without correction. Doing so may cause fire. In such cases, switch power off immediately, unplug AC adapter from AC outlet, and then contact the nearest KONICA MINOLTA SENSING authorized service facility.

	Caution (Failure to adhere to following points may result in injury or damage to this instrument or other property.)
	Use this instrument near AC outlet for easy plugging or unplugging in using AC adapter.
	Do not place this instrument on unstable or sloping surface which may drop or overturn it. Dropping or overturning may injure someone around. Take care not to drop this instrument when carrying.

Introduction

Thank you for purchasing our 2D Color Analyzer CA-2000 series. This instrument measures unevenness of luminance and color on various display unit or projector, backlight and car instrument panel in 2 dimension. Read this manual carefully before use.

"CA-2000" and CA-2000S are applied as representative examples for explanation and illustration respectively in this instruction manual. Only those with different specification are indicated model by model.

Packaging material

Retain accompanying packaging materials (carton, protector, and plastic bag) for future use.

This is delicate measurement instrument. Use packaging materials supplied in purchasing in case this instrument needs to be transferred for such purpose as maintenance in KONICA MINOLTA SENSING authorized service facility. These packaging materials are useful for minimizing shock or vibration to this instrument in such situation.

Should any of these packaging materials be lost or broken, contact the nearest KONICA MINOLTA SENSING authorized service facility.

Note on use

Operating environment

- Do not use this instrument outdoor since standard accessory AC adapter (AC-A22) is designed for indoor use.
- Never disassemble this instrument for being composed of delicate electronic components.
- Use this instrument at rated voltage of 100 V-240 V \sim . Connect AC power cord to AC outlet with rated voltage 100 V-240 V \sim and frequency 50 Hz-60 Hz. Connected voltage should not be outside the range of $\pm 10\%$ of nominal.
- This instrument is classified into a Pollution Degree 2 as instrument used mainly in manufacturing plant, laboratory, warehouse or equivalents. Use this instrument in metal dust free and non condensing potential environment.
- This instrument is categorized into Installation Category II as equipment connected to commercially available power source.
- If protective earth terminal is equipped with the PC to control this instrument, connect the PC terminal to a protective earth outlet. If not, electric shock may occur due to earth leakage.
- Take care not to enter foreign substance like water or metal in this instrument. Operating in such state causes serious danger.
- Do not use this instrument under direct sunlight or near heater. The internal temperature of this instrument becomes much higher than ambient temperature which may break this instrument. Also, be sure to keep good ventilation in using this instrument. Never cover air duct of this instrument.
- Avoid rapid change in ambient temperature which may form dew condensation.
- Avoid using this instrument in extremely dusty or humid place.
- Use this instrument at ambient temperature between 10°C and 30°C and relative humidity 70% or less with no condensation. Operating this instrument outside specified temperature and humidity range may unsatisfy its original performance.
- Even if the product is used within the specified operating temperature/humidity range, the displayed values may be affected by long-term conditions of use. If you have any question about specification, please contact the nearest KONICA MINOLTA SENSING authorized service facility.

This instrument

- Do not subject this instrument to strong impact or vibration.
- Do not forcibly pull, bend, or apply strong force to power cord for attached AC adapter or USB cable. This may result in snapping.
- Connect this unit to power source with minimal noise.
- Should breakage or abnormality be found during operation, switch power off immediately and unplug. Then, refer to "Error Check" on pages 35-37.
- Should this instrument break down, do not try to disassemble and repair it by yourself. Contact the nearest

Lens and filter inside lens mount on body

- Be sure that there is no dirt on surface of lens and filter inside lens mount on body before measurement. Correct measurement result cannot be obtained if dirt, dust or handsoil is left or uncleaned.
- Do not touch surface of lens and filter inside lens mount on body with hand.
- Lens and filter inside lens mount on body could become fogged up if ambient temperature fluctuates under high humidity. Be careful not to generate such condition for correct measurement cannot be performed.

Storage

Body

- Cover lens mount with standard accessory mount cover in storing lens in removed state.
- Do not store this instrument under direct sunlight or near heater. The internal temperature of this instrument could become much higher than ambient temperature which may break this instrument.
- Store this instrument at ambient temperature between 0°C and 30°C and relative humidity 70% or less with no condensation or between 30°C and 35°C and relative humidity 55% or less with no condensation. Storage under high temperature and humidity may deteriorate performance of this instrument. For added safety, we recommend storage with such drying agent as silica gel at room temperature.
- Even if the product is stored within the specified storage temperature/humidity range, the displayed values may be affected by long-term conditions of storage. If you have any question about specification, please contact the nearest KONICA MINOLTA SENSING authorized service facility.
- Take care not to form condensation. Avoid rapid change in ambient temperature when transferring body for storage.
- Put body in packaging box supplied when purchased or optional soft case (CA-A60) to store in safe place.

Lens

- Cover lens with lens cap, or lens hood with hood cap for storage.
- When you remove lens from body for storage, cover lens with lens cap and mount cap.

Temperature/Humidity conditions under which the instrument is used and stored

It is recommended that the instrument be used and stored under standard conditions (Temperature: 23°C; Relative humidity: 40%), and that areas subject to high temperature and/or humidity be avoided. In addition in order to maintain the measurement accuracy of this instrument, it is recommended that it be inspected regularly about once a year. For details on having the instrument inspected, please contact the nearest Konica Minolta Sensing authorized service facility.

Even if the product is used within the specified operating temperature/humidity range or stored within the specified storage temperature/humidity range, the displayed values may be affected by long-term conditions of use or storage.

If the instrument is left under the following high-temperature conditions for a long period of time, the displayed values may change as follows:

Temperature: 30°C; Relative humidity: 70%; Period under these conditions: 720 hours (30 days)

Accuracy: Luminance: ± 0.4 %; Chromaticity: ± 0.003

Inter-point error: Luminance: ± 0.2 %; Chromaticity: ± 0.0003

Temperature: 35°C; Relative humidity: 55%; Period under these conditions: 336 hours (14 days)

Accuracy: Luminance: ± 1 %; Chromaticity: ± 0.006

Inter-point error: Luminance: ± 0.5 %; Chromaticity: ± 0.001

These differences in display values are due to the instrument materials and/or components being affected by the temperature and humidity conditions of long-term use or storage. In particular, optical filters are easily affected by temperature or humidity. Although measures have been taken to improve resistance to temperature/humidity changes, the accumulated effect of long-term use or storage may affect the displayed values.

Cleaning

Body

- If this unit becomes dirty, wipe with dry and soft cloth. Do not use organic solvent like benzine or thinner and other chemical agent for cleaning. Should none of these methods be helpful, contact the nearest KONICA MINOLTA SENSING authorized service facility.

Lens and filter inside lens mount on body

- Should it be gotten dirt or dust, wipe off with dry and soft cloth or lens cleaning paper. Do not use organic solvent like benzine or thinner and other chemical agent for cleaning. Should none of these methods be helpful, contact the nearest KONICA MINOLTA SENSING authorized service facility.

Notes on transfer

- Use packaging material supplied when purchased to minimize vibration or shock generated during transfer.
- Put all materials including unit and accessories together in original packaging material when returning this instrument for service.

Maintenance

- Periodical checkup is recommended annually to maintain measurement accuracy of instrument. For details on checkup, contact the nearest KONICA MINOLTA SENSING authorized service facility.

CONTENTS

Safety Warnings and Cautions	1
Introduction	2
Note on use	2
Operating environment	2
This instrument	2
Lens and filter inside lens mount on body	3
Storage	3
Body	3
Lens	3
Cleaning	3
Body	3
Lens and filter inside lens mount on body	3
Notes on transfer	3
Maintenance	3
Standard Accessory	6
Optional Accessory	7
System Configuration	8
Names and Functions of Parts	10
<Body>	10
<Lens>	11

Installing

Goods/Environment to Prepare on Customer's Side ...	14
Controlling PC	14
Mounting stage	14
Blackout curtain (To quickly make darkroom-like condition) / Dark room	14
Installing	15
Placing Lens	16
Replacing lens	17
Connecting AC Adapter	18
Connection procedure	18
ON (I) / OFF (O) of Power Switch	19
To ON	19
To OFF	19
Connecting with PC	19
Operation procedure	19

Measurement

Measuring Flow	22
Starting Up and Ending System	23
Starting up	23
Connection recognition error	23
Ending	23
Setting Measurement Distance	24
Setting measurement distance	24

<Preparation>	24
<Shutter speed adjustment>	25
<Focusing>	25
Caution	26
Example of reference position to read distance ...	27
How to read distance in case of standard lens or telephoto lens ...	27
How to read distance in case of wide lens	27

Description

Sync Measurement	30
Backlight Cancellation	31
User Calibration	31
Influence by viewing angle	31
L_vTΔuv	32
<Relation between correlated color temperature T and color difference from blackbody locus Δuv>	32
Dominant Wavelength and Excitation Purity ...	33
<Dominant wavelength and excitation purity of spectrum color> ...	33
<Complementary wavelength and excitation purity of non-spectrum color>	33
Outer Dimensions	34
Error Check	35
Main Specification	38

Standard Accessory

Attached lens cap, mount cap, lens hood and hood cap corresponding with lens type for each model.

Lens Cap

- Place on lens for protection in not using this instrument.
For standard or telephoto lens
For wide lens

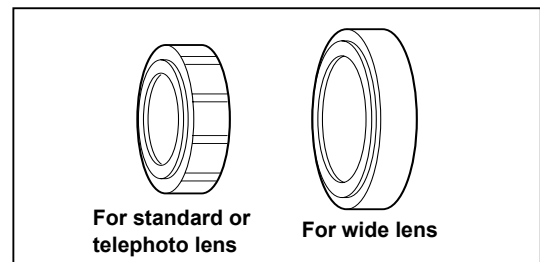

Mount Cap

- Place on lens mount for protection when lens is removed from body.
For standard or telephoto lens
For wide lens

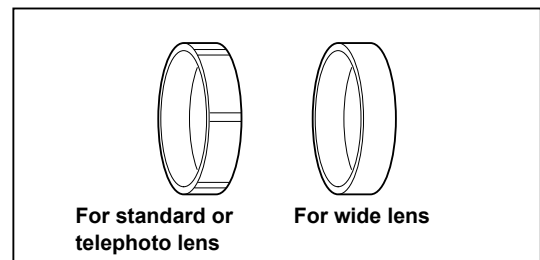

Lens Hood

- For standard or telephoto lens **CA-A68**
- For wide lens **CA-A69**
- For macro measurement **CA-A70**

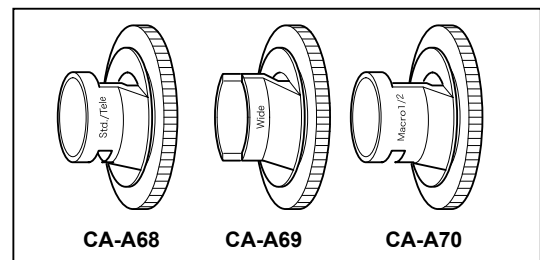

Hood Cap

- Place on lens for protection in not using this instrument.
For standard lens, telephoto lens, or macro measurement **CA-A71**
For wide lens **CA-A75**

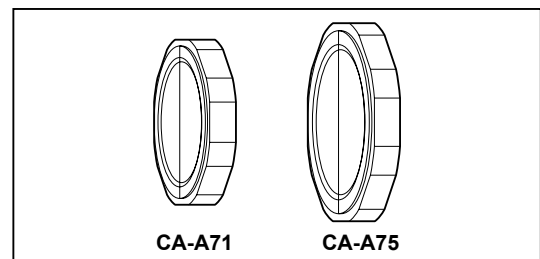

Mount Cover CA-A61

- Place for protection of lens mount of body when lens is removed.

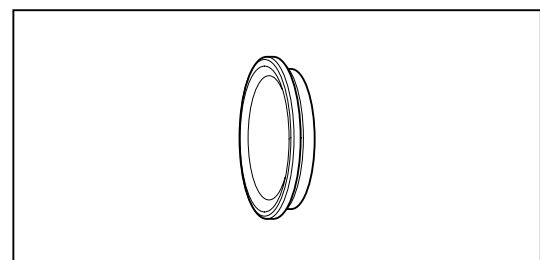

AC Adapter AC-A22

- Supplies power from AC outlet.
Input: 100 V-240 V ~ 1.2 A
50 Hz-60 Hz
Output: 12 V \equiv 4.0 A

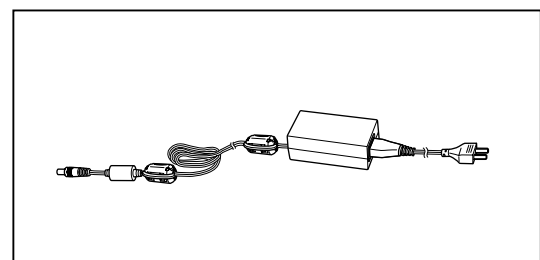

Data Management Software CA-S20w

- For data management of this instrument from PC.

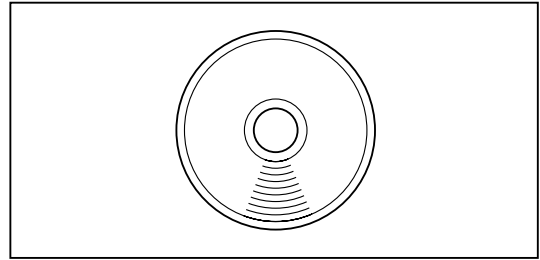
**USB Cable (3 m) IF-A18**

- Used for communication between this instrument and PC.

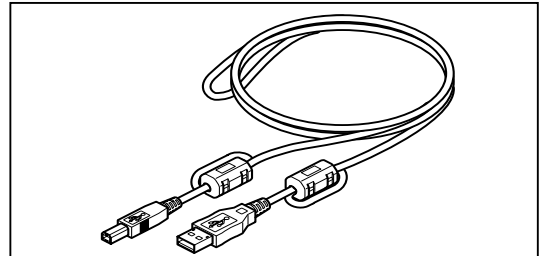
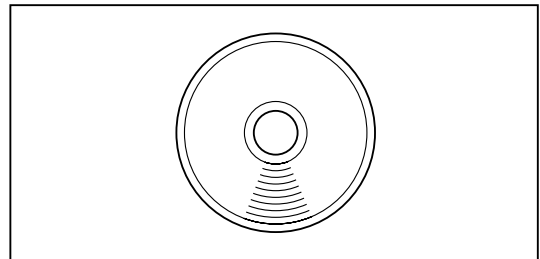
**Calibration Data DVD**

Optional Accessory

Soft Case CA-A60

- Used to keep this instrument and accessories or carry them with hand. Never use for transfer.

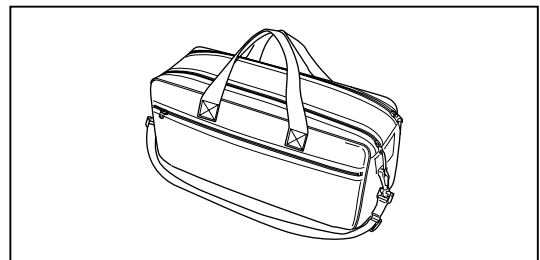
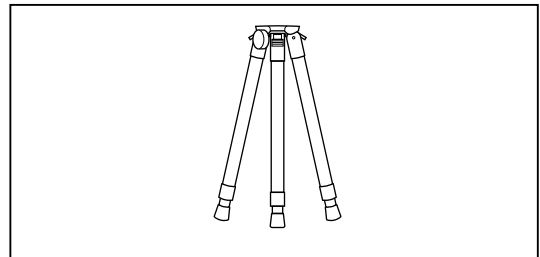
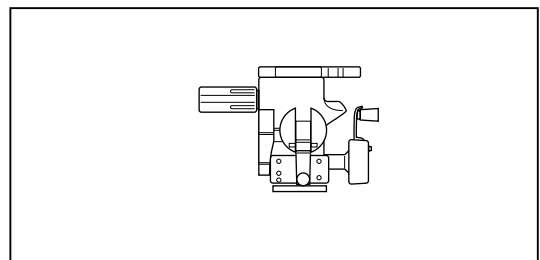
**Tripod CS-A3****Pan Head CS-A4**

System Configuration

CA-2000A (With all lenses)

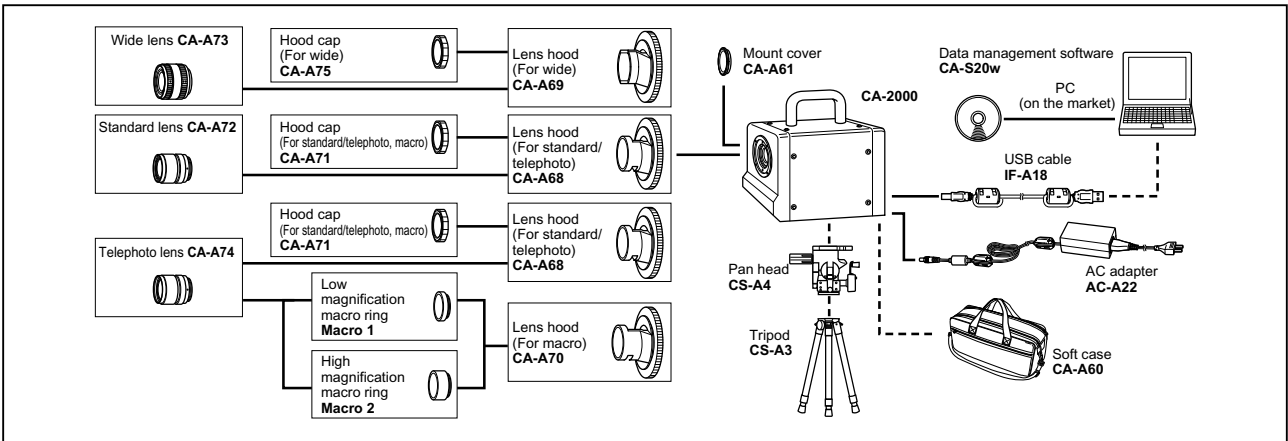

CA-2000S (With standard lens)

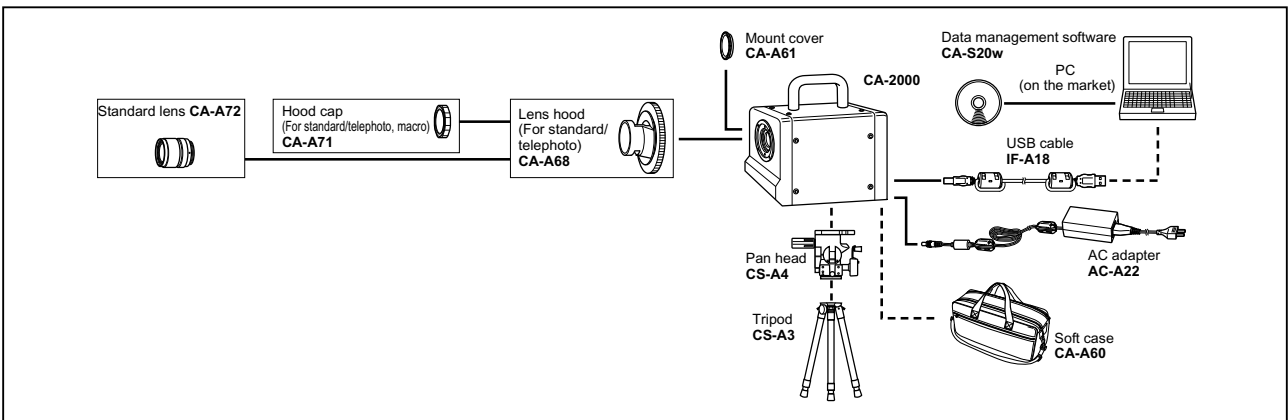

CA-2000W (With wide lens)

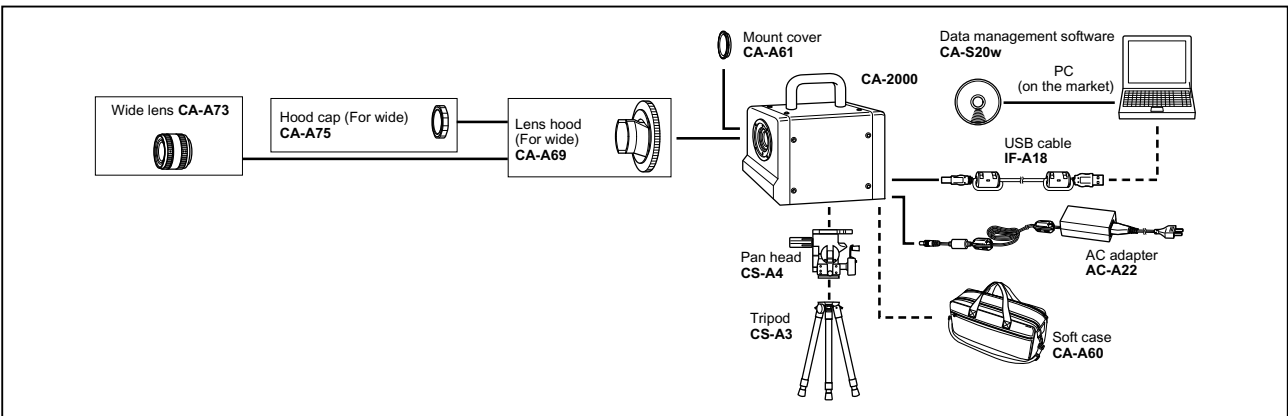

CA-2000T (With telephoto lens)

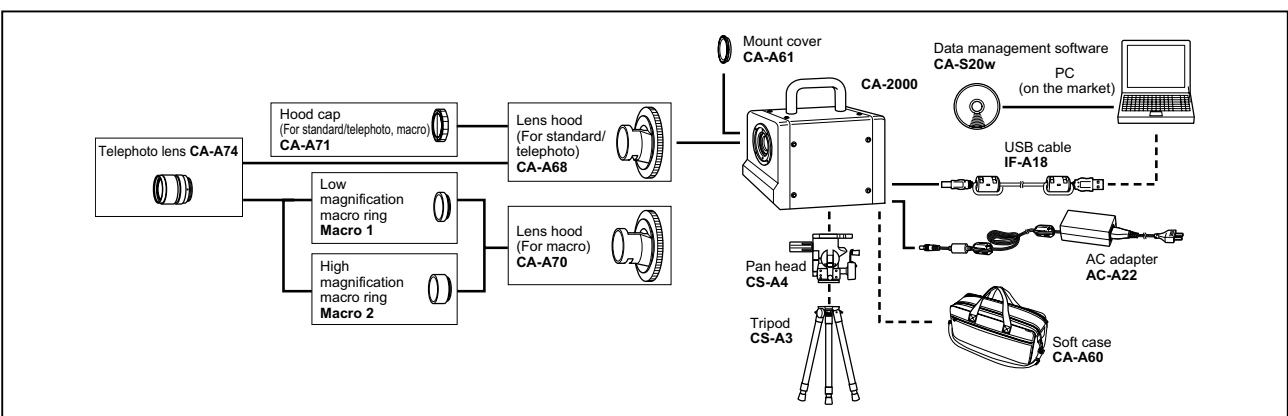

CA-2000SW (With standard and wide lenses)

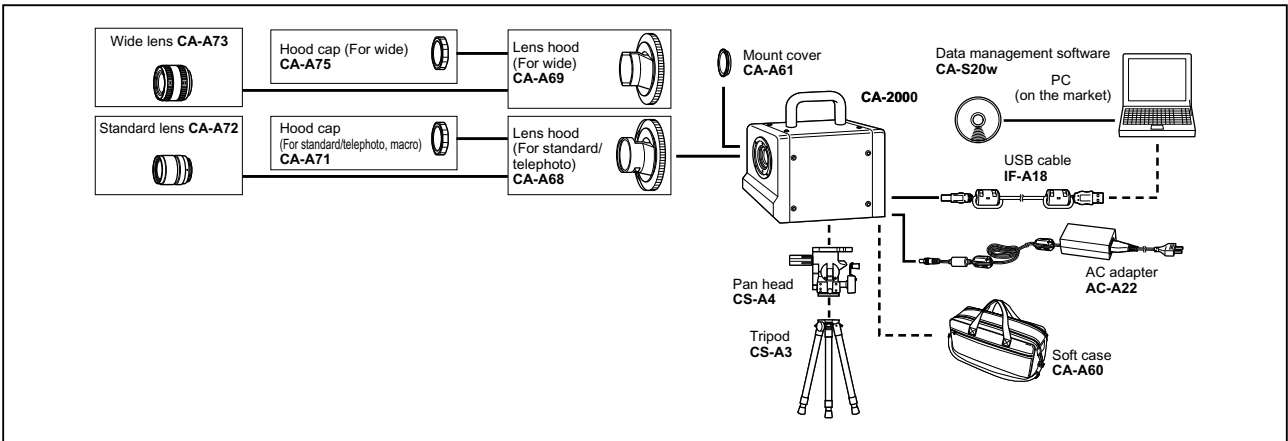

CA-2000ST (With standard and telephoto lenses)

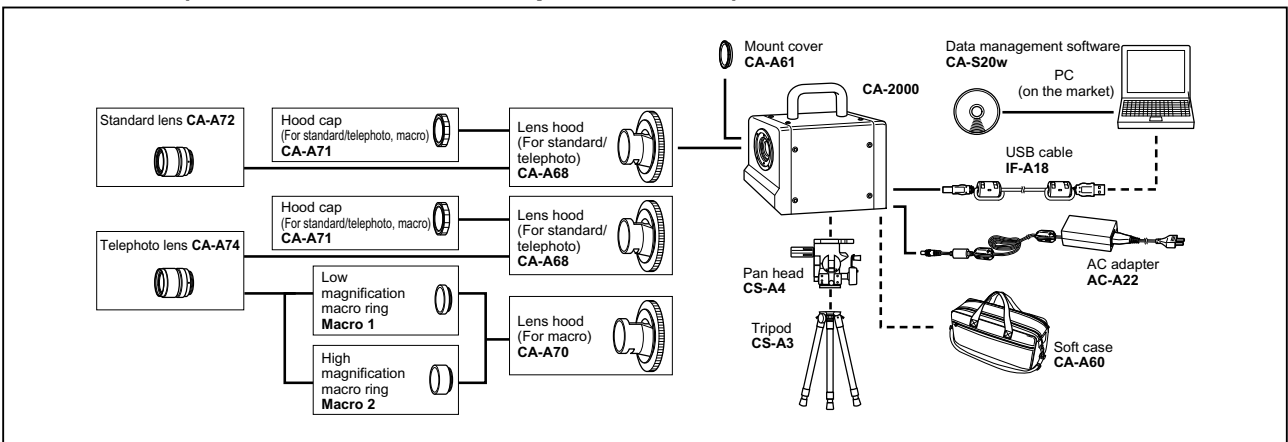

CA-2000WT (With wide and telephoto lenses)

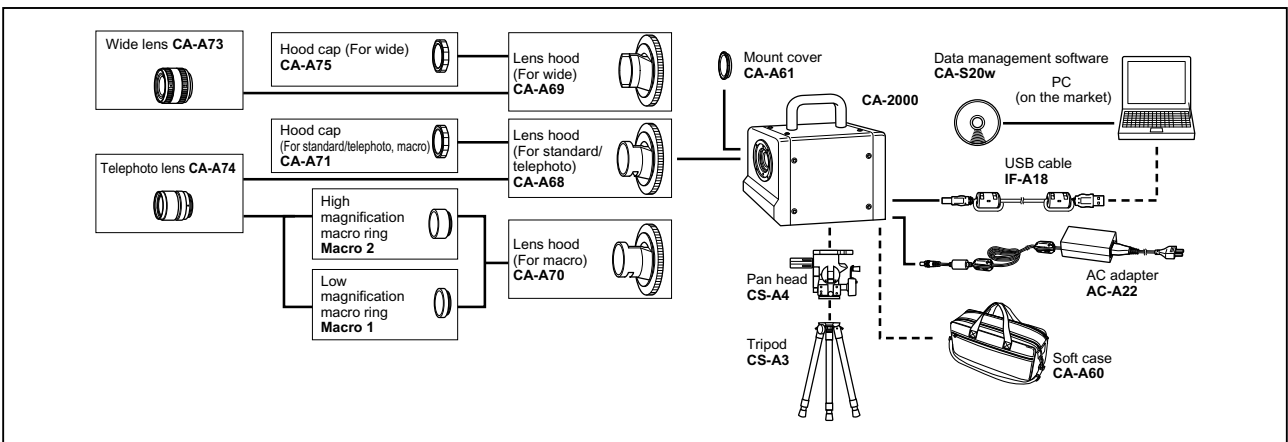

- Standard accessory
- Optional accessory

You can additionally purchase each lens regardless of your model.

Names and Functions of Parts

<Body>

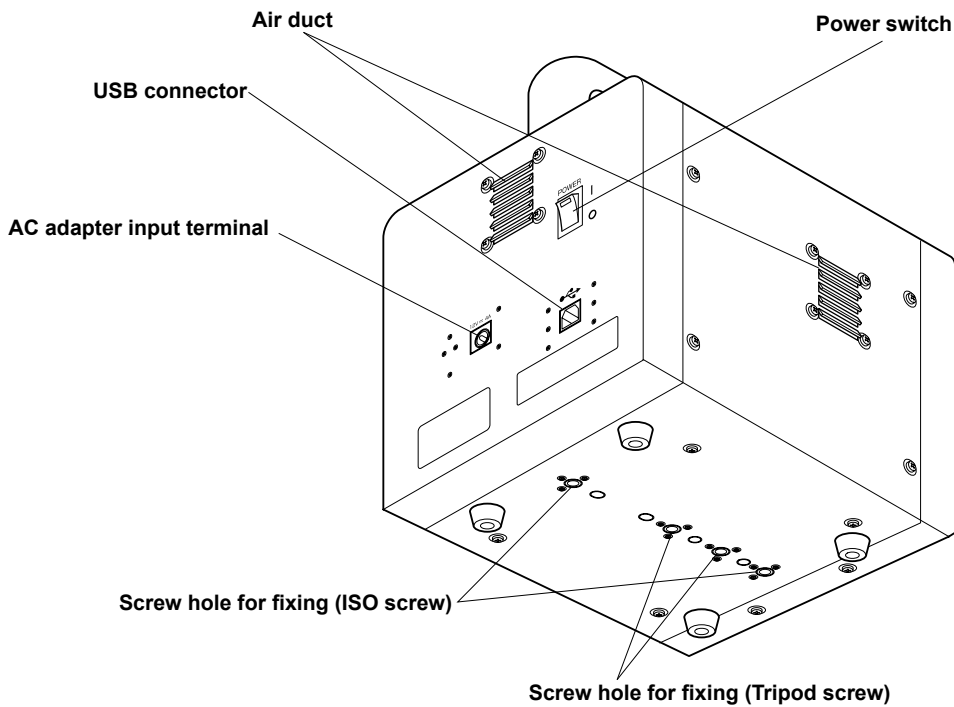
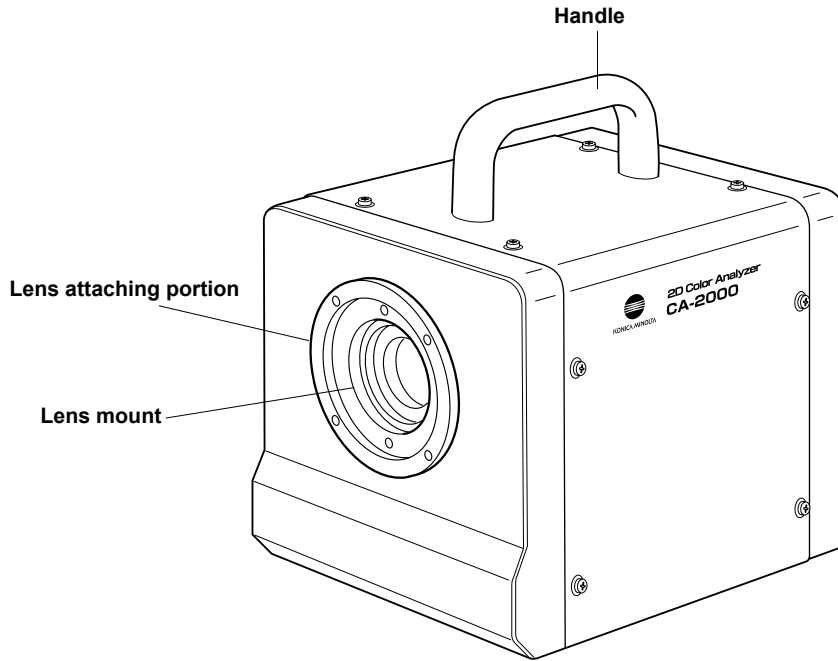

Power switch	Switches this instrument on/off. [■] side for ON; [○] side for OFF. Green LED lights up while switched on. (p.19)
AC adapter input terminal	To which accessory AC adapter is connected. (p.18)
USB connector	To which USB cable is connected when used with PC. (p.19)
Air duct	Air duct to air-cool interior. Do not cover here. Air-cooling fan built in this instrument operates while switched on.
Lens mount	To install lens on.
Lens attaching portion	To which lens hood is attached.
Screw hole for fixing	Used to set this instrument on tripod or jig.

<Lens>

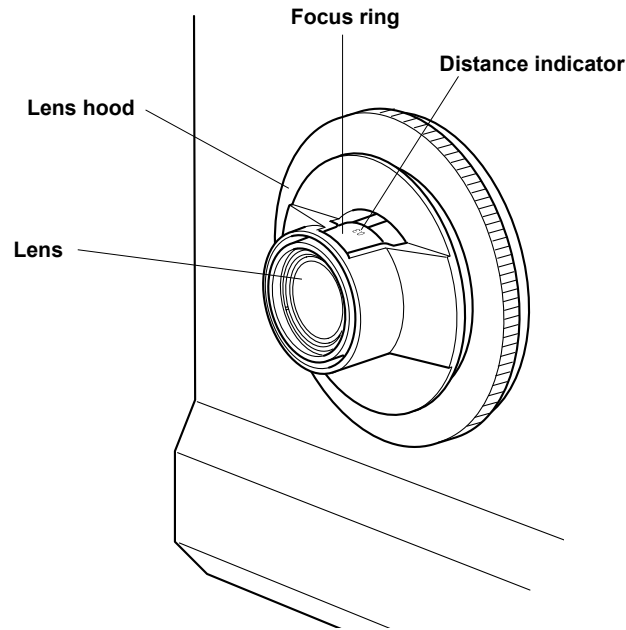

Body and lens arranged in a pair are calibrated. Pair those with identical numbers.

CA-2000A, CA-2000S, CA-2000SW, CA-2000ST

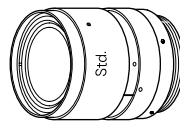

Standard lens

CA-2000A, CA-2000W, CA-2000SW, CA-2000WT

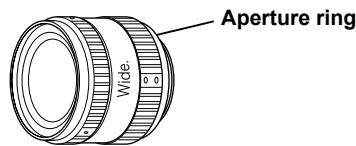

Wide lens

CA-2000A, CA-2000T, CA-2000ST, CA-2000WT

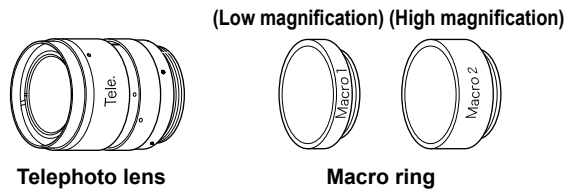

Telephoto lens

Macro ring

Lens hood

Protects lens. Remove this once when replacing lens.

Focus ring

Adjusts focus.

Aperture ring

Being fixed, this should not be used. Do not operate by removing or revolving screw for this would deteriorate the performance.

Macro ring

Placed between telephoto lens and body when utilizing telephoto lens for macro. You cannot place 2 types of macro ring simultaneously.

Installing

Goods/Environment to Prepare on Customer's Side

Get prepared for below goods/environment before using this instrument.

Controlling PC

OS	: Windows® XP Professional Service Pack 2 Windows® XP Professional x64 Edition Windows® Vista Business 32-bit (x86) Windows® Vista Business 64-bit (x64) (English, Japanese and Korean versions For Windows® XP Professional x64 Edition, English and Japanese versions only)
CPU	: Pentium® 4 2.8 GHz or higher
Memory	: 1024 MB or larger
Hard Disk	: Needs free space of 80 MB at least on system drive (where OS is installed) In addition, each lens needs the following free spaces for installing calibration data. For standard lens: approx. 540 MB For wide lens: approx. 470 MB For telephoto lens: approx. 1.3 GB Also, to save measurement data on hard disk, additional free space is required. (approx. 110MB for 10 measurement data in resolution 980x980) Further empty space is required for temporary working area. For more details, see the instruction manual for data management software CA-S20w.
Display	: Can display 1280 x 1024 dots / 65536 colors (High Color: 16 bits) at least
Others	: CD-ROM drive, 1 unit (required for installation) DVD-ROM drive, 1 unit (required for installing calibration data) (Instead of the above two drives, 1 unit of combo drive which can read both CD-R and DVD-R media is available.) USB port (2.0 compatible) (Type A connector specification), 1 unit (required for connecting the measurement instrument) Excel 2003 (required for continuous measurement with the automation function)

In addition, following items are useful.

Mounting stage

Table on which this instrument is installed. Below are recommended conditions.

- Can change measurement distance according to measurement object.
- Painted with black to prevent the entrance of light diffusely reflecting.

Blackout curtain (quickly prepared darkroom) / Dark room

Needed to block this instrument and measurement object from outside light.

Get prepared for blackout curtain for quickly prepared dark room or dark room.

Installing



Warning for safety



Do not use this instrument in places where flammable or combustible gases (gasoline etc.) are present. Doing so may cause fire.



Caution for safety



Do not place this instrument on unstable or sloping surface which may drop or overturn it. Dropping or overturning may injure someone around. Take care not to drop this instrument when carrying.

To set this instrument on tripod or jig, use screw hole for fixing at the bottom of this instrument.

2 type holes are available as follows;

Tripod screw hole: To set on tripod. Screw depth is 6.5 mm.

ISO screw hole: To set on jig. User ISO 5 mm screw and screw depth is 6.5 mm.

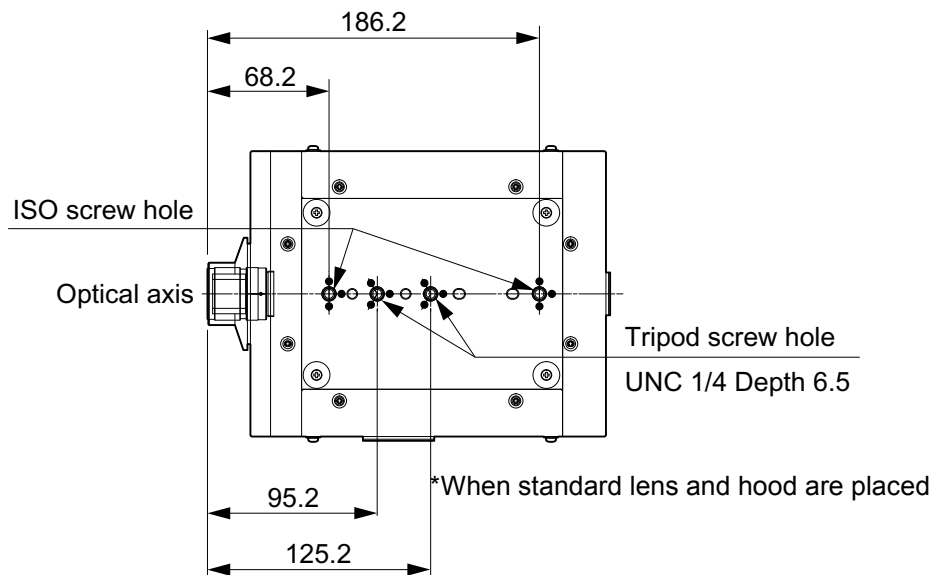

For further detail, see p.34.

Placing Lens

Below shows lens type accompanying respective CA-2000 series. Lens hood is served as standard corresponding to lens type.

CA-2000A	Standard, wide and telephoto lenses, and 2 macro rings
CA-2000S	Standard lens
CA-2000W	Wide lens
CA-2000T	Telephoto lens and 2 macro rings
CA-2000SW	Standard and wide lenses
CA-2000ST	Standard and telephoto lenses, and 2 macro rings
CA-2000WT	Wide and telephoto lenses, and 2 macro rings

Operation procedure

1. Remove mount cover from lens mount on body.

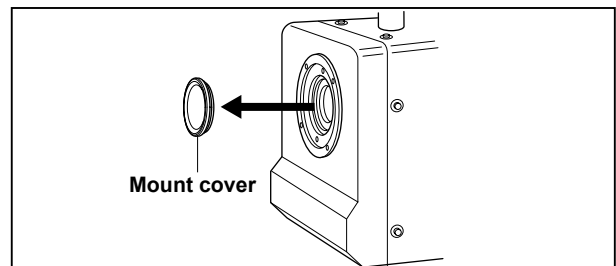

2. Place lens on lens mount before rotating clockwise.

- Be sure to insert lens straightly. If forcibly put aslant, lens mount could be broken.
- Revolve lens until fixed.

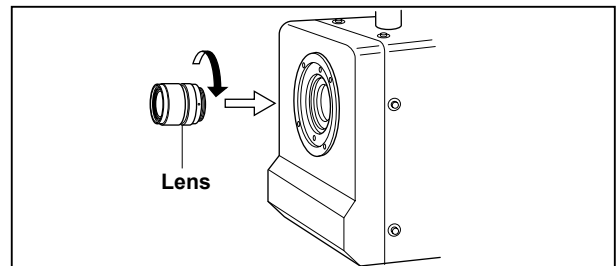

For CA-2000A, CA-2000T, CA-2000ST, or CA-2000WT

In using a macro ring for either of CA-2000A, CA-2000T, CA-2000ST, or CA-2000WT, sandwich it between lens and lens mount.

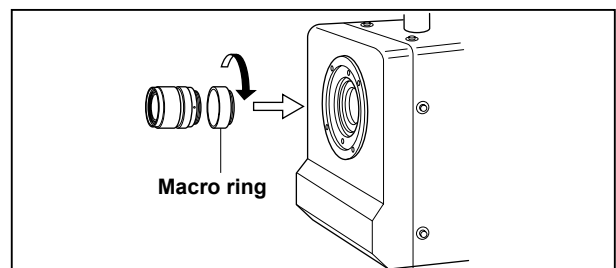

3. Align 2 pins of lens hood and 2 holes of body. Then, insert lens hood as if it covers lens. Finally, rotate screw portion of lens hood clockwise.

- Select appropriate lens hood depending on lens type. Inappropriate lens hood may cause the lens head to be positioned back from the lens hood, which leads to incorrect measurement.
- Hold the circumference of lens hood.
- Rotate screw portion of lens hood until fixed.

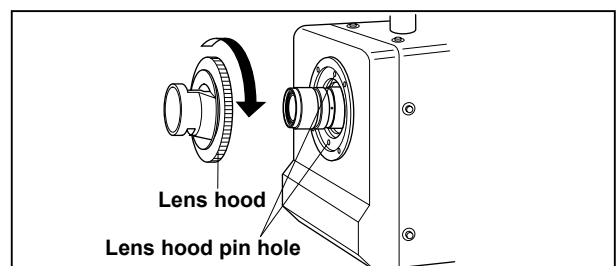

Connecting AC Adapter

Use accessory AC adapter for power source.



Warning (Failure to adhere to the following points may result in death or serious injury.)



Always use the AC adapter and power cord supplied as a standard accessory or optional (AC-A22), and connect it to indoor AC outlet of rated voltage 100 V-240 V ~ and frequency 50 Hz-60 Hz. Failure to follow either of these may result in damage to unit, fire or electric shock.



If this instrument is not used for a long time, disconnect AC adapter from AC outlet. Accumulated dirt or water on prongs of AC adapter plug may cause fire and should be removed. Be sure to remove before use.



Do not forcibly pull any part on power cord when unplugging since this may cause fire or electric shock. Gently disconnect by holding plug. Also, do not handle power plug with wet hands. Doing so may cause electric shock.



Do not forcibly bend, twist or pull power cord. Also, do not place heavy object on power cord, or damage or modify one. Any of these may cause fire or electric shock due to damage to power cord.



Do not disassemble or modify this instrument or AC adapter. Doing so may cause fire or electric shock.



Should this instrument or AC adapter be damaged or smoke or odd smell be generated, do not keep using one without correction. Doing so may cause fire. Switch power off immediately, unplug AC adapter from AC outlet in such case. If operated on battery, remove battery and contact the nearest KONICA MINOLTA SENSING authorized service facility.



Caution (Failure to adhere to following points may result in injury or damage to instrument or other property.)



Use this instrument near AC outlet for easy plugging or unplugging in using AC adapter.

Connection procedure

1. Be sure that power switch is OFF ([○] mark pressed).

2. Connect AC adapter plug to AC adapter input terminal of body.

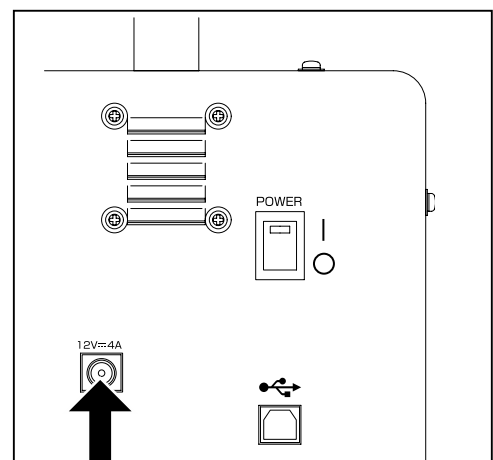

3. Plug AC adapter to outlet (AC 100 V-240 V ~, 50 Hz-60 Hz).

- Insert AC adapter plug all the way seated in AC outlet.

ON (|) / OFF (○) of Power Switch

To ON

1. Press [|] side of power switch to ON.

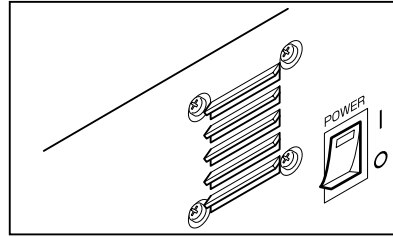

To OFF

2. Press [○] side of power switch to OFF after completion of measurement.

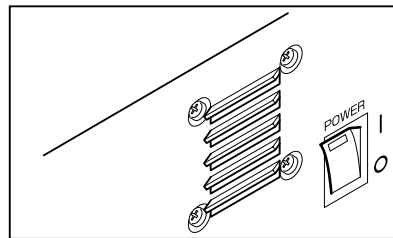

Connecting with PC

Before connecting CA-2000 body with PC, install software CA-S20w in PC. (For detail, see the instruction manual for data management software CA-S20w.)

Use accessory USB cable (3 m) IF-A18 for this purpose.

No problem would occur if USB cable is plugged or unplugged while power is on, but instruction here indicates the case when power is off.

Operation procedure

1. Switch power off.
2. Connect USB cable to USB connector on body.
3. Insert all the way to the end. Check whether the connection is secure.

Communication interface of this instrument complies with USB2.0.

Always hold plug portion of USB cable in unplugging. Never hold cord portion to unplug.

Match the USB cable plug shape with the slot of either body or PC before inserting.

Any USB port is usable on PC if it has multiple, but abnormal operation could be detected on PC in case that it is used together with other USB device than CA-2000.

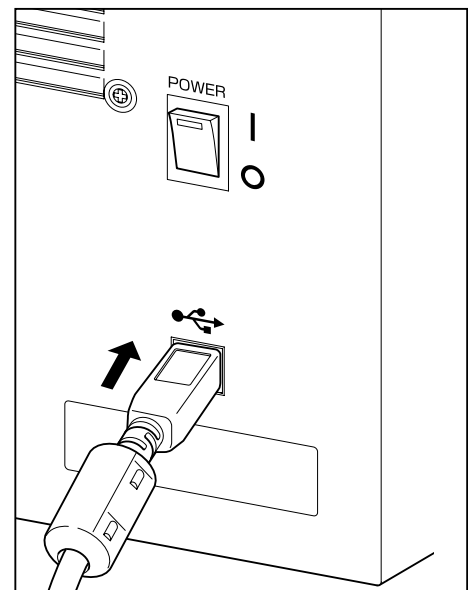

Measurement

Measuring Flow

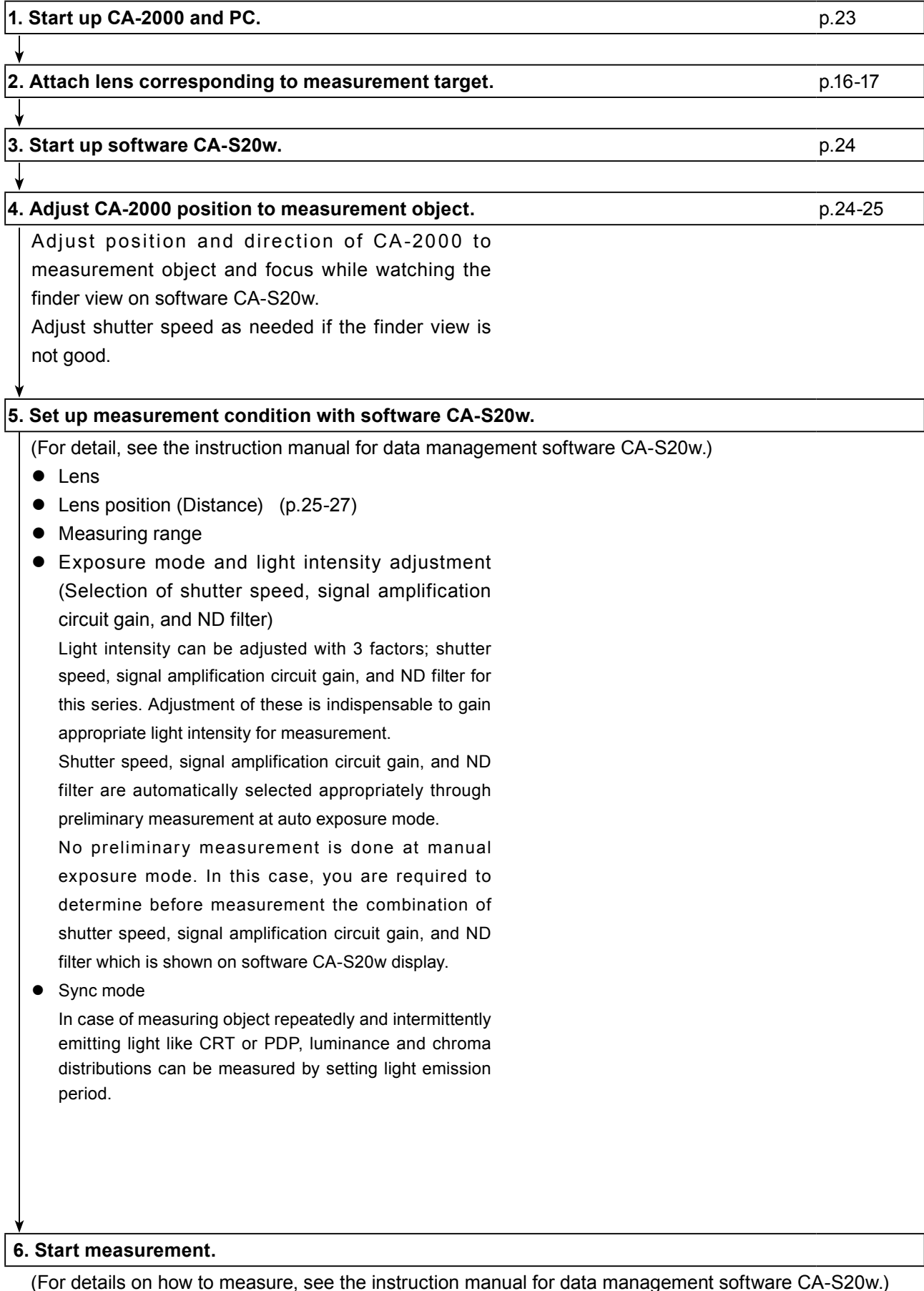

Starting Up and Ending System

Starting up

Switch power on as instructed. If not, erroneous operation could occur.

1. Switch power on for body. (Press [I] side.)

- Motor sounds indicating controller inside machine starts initialization.
- Fan inside body starts to run.
- 15-minute warm-up at least (to leave in this state after switching on.) is recommended for accurate measurement.

2. Start up Windows by turning on controlling PC.

3. Connect PC and CA-2000 with USB cable.

- PC recognizes that CA-2000 has been connected.

4. Select "CA-S20w" from Start → [Program].

- CA-S20w starts to run.

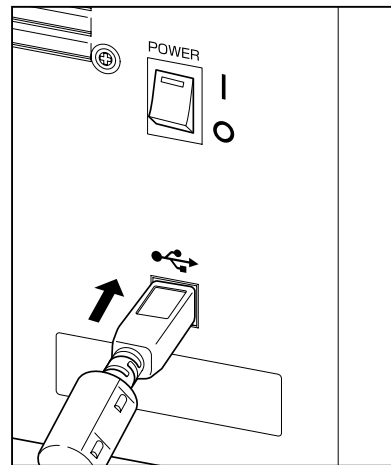

Connection recognition error

Sometimes, PC fails to recognize its connection with CA-2000 if CA-2000 was switched on after connected with USB cable to PC which had already started up. Such condition could not allow control of CA-2000 from software. Start up this instrument according to the procedure as above again.

- In case that PC has already started, unplug USB cable once and then connect after switching CA-2000 on.
- Switch CA-2000 on before PC if USB cable cannot be unplugged for some reason concerning setting. Should connection error occur, unplug USB cable once and connect again. Then, both can start up normally.

Ending

1. Select "End CA-S20w" from "File" of menu bar.

- CA-S20w ends.
- You can finish through standard application operation of OS.

2. Finish Windows and switch off PC.

3. Switch off body. (Press [O] side.)

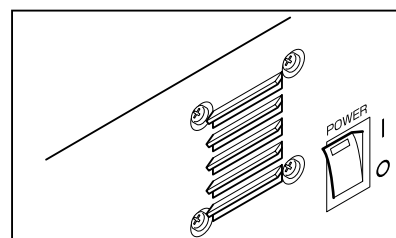

Setting Measurement Distance

Setting measurement distance

Optical lens features in varying light intensity and illuminance distribution of imaging surface if focus ring is rotated. Therefore, lens calibration has been done lens by lens according to the distance from lens to measurement object (distance indicator of focus ring). Each has its own calibration coefficient.

Correct calibration coefficient can be applied by selecting what kind of lens is used for which focusing distance, in software CA-S20w.

<Preparation>

1. Start up system.
2. Start up software CA-S20w.
 - For detail, see the instruction manual for data management software CA-S20w.
3. Open Measure dialog of software CA-S20w.
 - For detail, see the instruction manual for data management software CA-S20w.
4. Set measurement object on measuring stand.
5. Set CA-2000 on appropriate position referring to below table.

CA-2000A, CA-2000S, CA-2000SW, CA-2000ST

Standard lens	
Size of measurement object (One-side length of square)	Measurement distance
98 mm approx.	250 mm
210 mm approx.	500 mm
440 mm approx.	1000 mm
890 mm approx.	2000 mm

CA-2000A, CA-2000W, CA-2000SW, CA-2000WT

Wide lens	
Size of measurement object (One-side length of square)	Measurement distance
145 mm approx.	200 mm
410 mm approx.	500 mm
850 mm approx.	1000 mm
1770 mm approx.	2000 mm

CA-2000A, CA-2000T, CA-2000ST, CA-2000WT

Telephoto lens		With low-magnification macro ring (Macro 1)	
Size of measurement object (One-side length of square)	Measurement distance	Size of measurement object (One-side length of square)	Measurement distance
115 mm approx.	900 mm approx.	57 mm approx.	500 mm
275 mm approx.	2000 mm approx.	With high-magnification macro ring (Macro 2)	
420 mm approx.	3000 mm approx.	Size of measurement object (One-side length of square)	Measurement distance
		27 mm approx.	300 mm

<Shutter speed adjustment>**6. Select shutter speed to obtain the brightness under which focusing is easy while watching the finder view of software CA-S20w.**

- For detail, see the instruction manual for data management software CA-S20w.

<Focusing>**7. Rotate focus ring of lens for adjustment while watching the finder view of software CA-S20w.**

- If you use telephoto lens with a macro ring for focusing, fix the focus-ring position of telephoto lens to infinity and adjust the distance between CA-2000 and the measurement object while checking the finder view.
- Stripe-shape noise (moire) may be sometimes generated in the finder view. In this case, you can change to the distance which hardly causes the moire stripe or obscure the focus to decrease influence of the moire stripe.

8. Select the closest reading distance of focus ring among choices of "Lense Position" of Measure dialog of software.

- Below shows reference position to read focus ring distance indicator.

CA-2000A, CA-2000S, CA-2000SW, CA-2000ST

Standard lens		
Distance	With distance label	On indicator
0.25 m	○	Decimal point indicator position (See Figure 1-1.)
		Intermediate indicator between previous and next reference positions (Center) (See Figure 1-2.)
0.3 m	○	Decimal point indicator position
		Intermediate indicator between previous and next reference positions (Center)
0.5 m	○	Decimal point indicator position
		Intermediate indicator between previous and next reference positions (Center) (See Figure 1-3.)
1 m	○	Center of "1"
		Intermediate indicator between previous and next reference positions (Center)
∞	○	End of focus-ring travel ([∞] side)

CA-2000A, CA-2000S, CA-2000SW, CA-2000ST

Wide lens		
Distance	With distance label	On indicator
0.2 m	○	Indicator position (See Figure 3-1.)
0.24 m	○	Indicator position
0.3 m	○	Indicator position (See Figure 3-2.)
0.5 m	○	Indicator position
1 m	○	Indicator position
∞	○	Indicator position

CA-2000A, CA-2000S, CA-2000SW, CA-2000ST

Wide lens		
Distance	With distance label	On indicator
0.9 m	○	Decimal point indicator position (See Figure 2-1.)
		Intermediate indicator between previous and next reference positions (Center)
1 m	○	Center of "1"
		Intermediate indicator between previous and next reference positions in 1:2 (short-distance side) (See Figure 2-2.)
		Intermediate indicator between previous and next reference positions in 2:1 (long-distance side) (See Figure 2-3.)
1.5 m	○	Decimal point indicator position
		Intermediate indicator between previous and next reference positions in 1:2 (short-distance side)
		Intermediate indicator between previous and next reference positions in 2:1 (long-distance side)
3 m	○	Center of "3"
		Intermediate indicator between previous and next reference positions in 1:2 (short-distance side)
		Intermediate indicator between previous and next reference positions in 2:1 (long-distance side)
∞	○	End of focus-ring travel ([∞] side)
With low-magnification macro ring (Macro 1)		
Distance	With distance label	Precise position on focus ring
∞	○	End of focus-ring travel ([∞] side)
With high-magnification macro ring (Macro 2)		
Distance	With distance label	Precise position on focus ring
∞	○	End of focus-ring travel ([∞] side)

Caution

The 28 points listed above are the points for which the CA-2000 lenses have been calculated. Highest measurement accuracy is assured only when measurements are taken at these listed conditions. When measurements are taken at any distance other than the calibrated points listed above, use the calibration coefficient for the calibration point closest to the measurement distance. However, the results in such case may be less accurate than if measurements were taken at a calibration point distance.

Example of reference position to read distance

How to read distance in case of standard lens or telephoto lens

The ring (focus ring) on which number values are written rotates in case of standard lens or telephoto lens. If the "distance indicator" includes decimal point, "." is determined as reference position; and if it does not include decimal point, the center of the number or $[\infty]$ is determined as reference position.

Standard lens

Figure 1-1
Example when setting to "0.25"

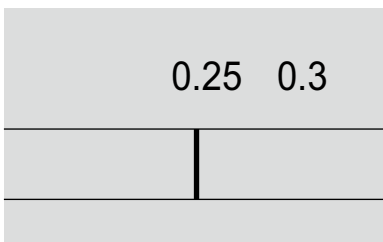
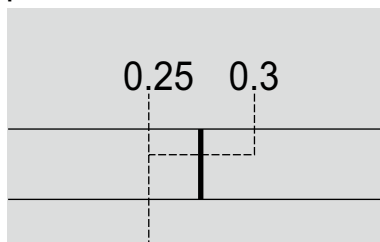

Figure 1-2
Example when setting to "diverting point between 0.25 and 0.3 in 1:1"



Set in reference of the 1/2 position between decimal points of 0.25 and 0.3.

Figure 1-3
Example when setting to "diverting point between 0.5 and 1 in 1:1"



Set in reference of the 1/2 position between decimal point of 0.5 and the center of 1.

Telephoto lens

Figure 2-1
Example when setting to "0.9"

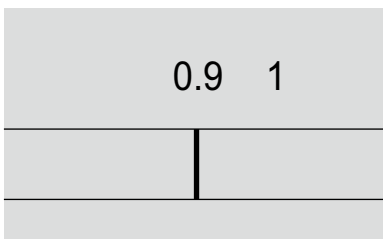
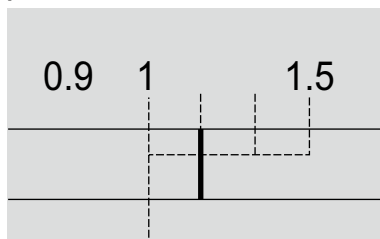
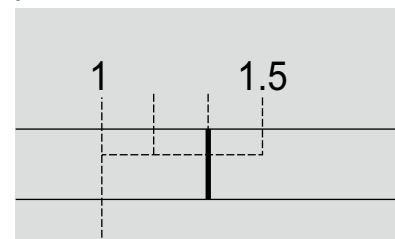

Figure 2-2
Example when setting to "diverting point between 1 and 1.5 in 1:2"



Set in reference of the 1/3 position between the center of 1 and decimal point of 1.5.

Figure 2-3
Example when setting to "diverting point between 1 and 1.5 in 2:1"



Set in reference of the 2/3 position between the center of 1 and decimal point of 1.5.

How to read distance in case of wide lens

The ring (focus ring) on which indicator position (the white circle in the figures below) is written rotates in case of wide lens. Set the indicator position to the line of number value.

Wide lens

Figure 3-1
Example when setting to "0.2"

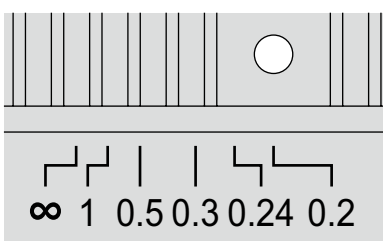
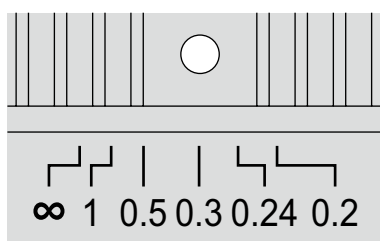

Figure 3-2
Example when setting to "0.3"





Description

Sync Measurement

In case of measuring object repeatedly and intermittently emitting light like CRT or PDP, luminance and chroma distributions can be measured steadily by setting light emission period.

Below shows an example of measurement result of CRT. Left is an image obtained light emission period being ignored, and right with the most adequate exposure time matching light emission period. While striped unevenness appears on the left due to the influence by CRT scanning, none of such phenomenon can be seen on the right.

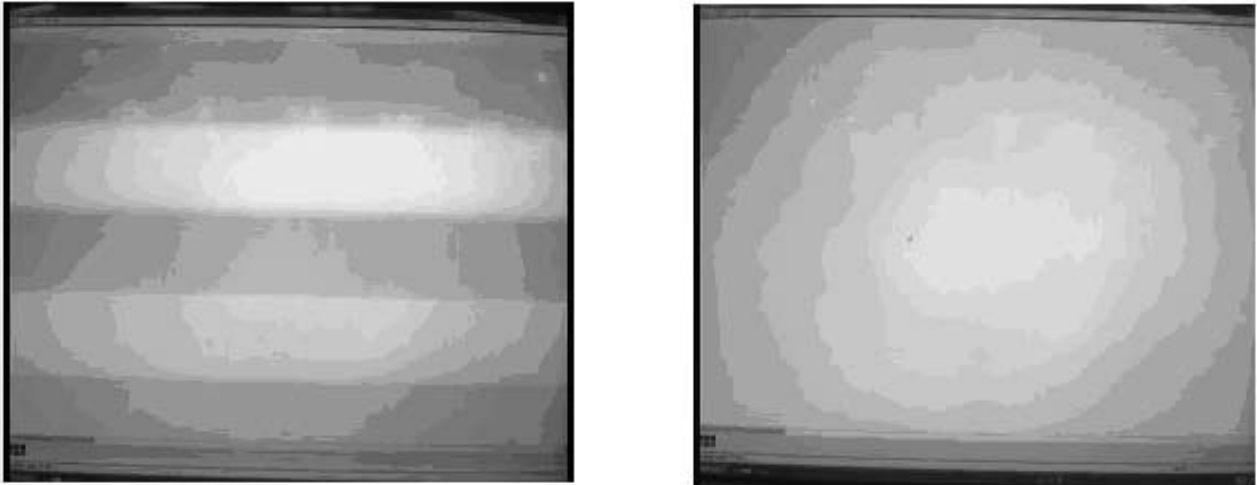

Because light emission timing is different depending on the screen area for CRT, which emits light through electron beam scanning, influence by intermittent light emission is found in the form of above shown unevenness. On the other hand, no unevenness occurs like CRT when entire screen flashes simultaneously like PDP, but measurement value varies with each measurement.

Below shows an example of measurement result of PDP. The graphs show both the synchronous and asynchronous measurement results (the average value in 100 x 100 pixels of the center area) when the same area was measured ten times in succession. While luminance and chromaticity are stable in synchronous measurement, the values obtained by asynchronous measurement change remarkably.

Luminance

(Difference between the average value of ten times measurement and each measurement value is displayed in percentage)

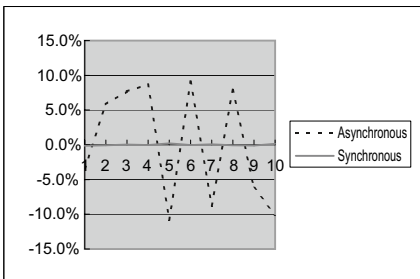

Chromaticity

(Difference between the average value of ten times measurement and each measurement value)

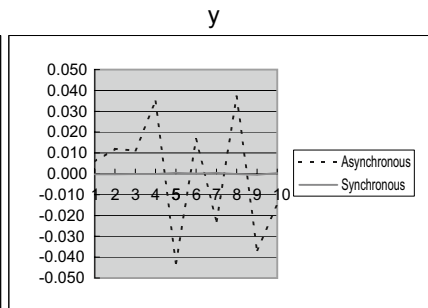
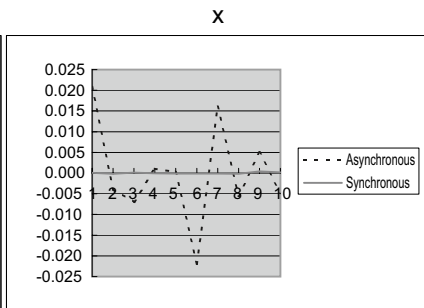

Backlight Cancellation

To evaluate the evenness of optical part (optical waveguide for LCD, for example) which constitutes display, evaluation object is put on some kind of light source like backlight.

However, this method gives negative impact for the light source itself generates unevenness.

You could evaluate fixing reference light source, but this does not realize objective evaluation of the evenness of optical part. With backlight cancellation function of CA-2000, light source unevenness data can be stored through previous measurement of light source or backlight to offset light source unevenness element from the sum of measurement results of light source and optical part. Thus, objective measurement result can be gained for optical part evenness without effect of light source unevenness.

User Calibration

Measurement error in luminance and chroma, or difference with the reference value controlled by the client sometimes arise because of the gap between spectral sensitivity of this instrument and CIE1931 color-matching function. In this case, you can use the user calibration function to calibrate measurement values.

CA-2000 applies roughly 2 types of calibration methods to calculate the calibration coefficient. One is monotint calibration and the other RGB matrix one. You can use monotint calibration to perform the user calibration relatively easily, because the calibration coefficient will be generated only by entering values of luminance and chroma for one color (ex. white) before/after calibration. RGB matrix calibration is used to calculate the calibration coefficient by entering values of luminance and chroma for two or more colors (ex. RGB or RGBW) before/after calibration. This method has an advantage to obtain the high calibration result in the wide rage of chroma.

CA-2000 uses the calibration coefficient calculated by either of monotint or RGB matrix calibration method to make a calculation uniformly on entire screen, which enables to calibrate the measurement values for entire screen.

$L_v T \Delta uv$

Following factors can be acquired as measurement value with $L_v T \Delta uv$ as color space of this instrument.

- L_v : Luminance
- T : Correlated color temperature
- Δuv : Color difference from blackbody locus

While L_v stands for luminance, T and Δuv for color in $L_v T \Delta uv$.

<Relation between correlated color temperature T and color difference from blackbody locus Δuv >

Color temperature refers to the temperature of blackbody (perfect radiator) which has equal chromaticity coordinates to certain light. However, color temperature only represents colors on blackbody locus.

Correlated color temperature, slightly wider interpretation of color temperature, is very useful to eliminate such problem. Here, correlated color temperature covers those which are slightly outside the range of that of blackbody locus.

If a certain color positions on isotherm line, the intersection point of isotherm line and blackbody locus is indicated as correlated color temperature for the color. Isotherm line means line on chromaticity coordinates which is a set of colors visually close to color temperature on blackbody locus.

However, since all colors on an isotherm line are represented with equal correlated color temperature, it is not possible to describe color only with correlated color temperature. To solve that, Δuv , deviation of correlated color temperature T from blackbody locus, is to apply for that purpose. If Δuv exists above blackbody locus, it is represented with "+", and below, with "-".

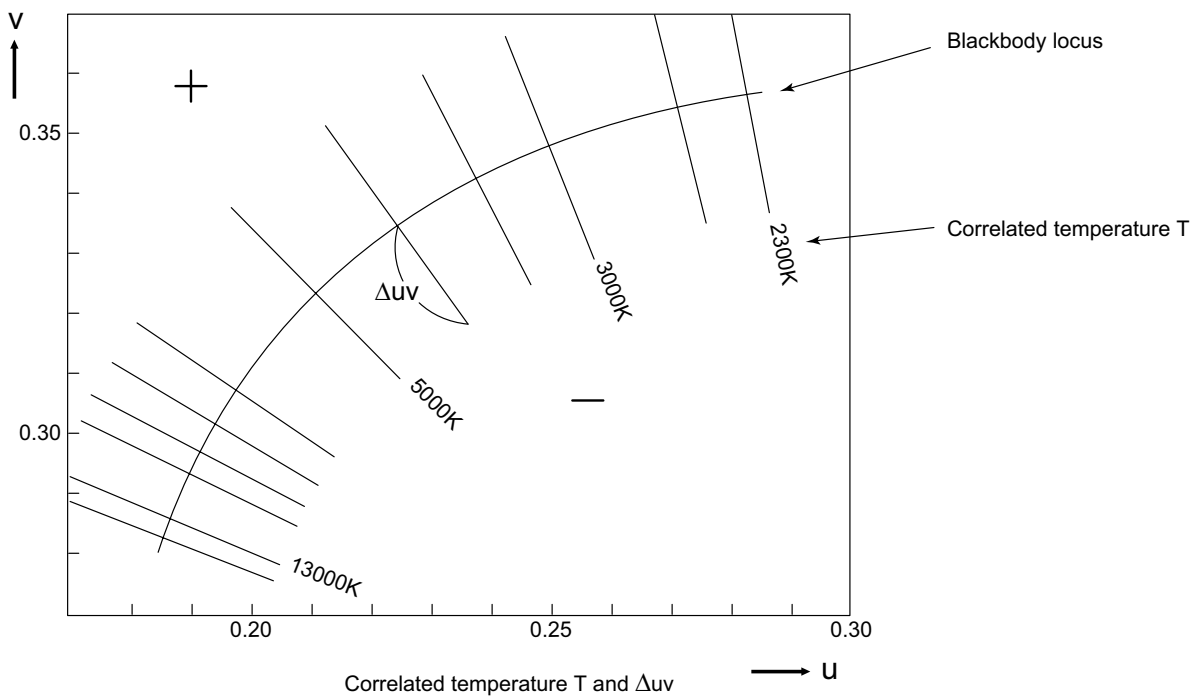

Dominant Wavelength and Excitation Purity

While curve VScSR indicates spectrum locus, point N white point (chromaticity point on complete diffusion radiation surface) in below chromaticity diagram (x, y). Spectrum color indicates the color of which chromaticity point exists in the area surrounded by spectrum locus, lines VN and NR, and non-spectrum color the color inside triangle NVR comprising purple boundary VR and white point N.

<Dominant wavelength and excitation purity of spectrum color>

Dominant wavelength indicates wavelength corresponding to S, intersection point of extension of NC and spectrum locus (curve VScSR), if chromaticity point C is gained through measurement. Dominant wavelength is represented with a symbol λ_d . The ratio of line NC length to line NS is called excitation purity and represented with a symbol p_e .

<Complementary wavelength and excitation purity of non-spectrum color>

When chromaticity point C' is gained through measurement, the extension of NC' to C' direction does not cross with spectrum locus, but with purple boundary.

In this case, wavelength corresponding to Sc, intersection point of extension of NC' to N direction and spectrum locus, is referred to as complementary wavelength which is symbolized with λ_c . The ratio of line NC' length to NS' is called excitation purity and represented with a symbol $p_{e'}$.

Excitation purities of spectrum and non-spectrum colors are derived with the following formula when (x_n, y_n) is chromaticity coordinates of point N, (x, y) of point C, (x_λ, y_λ) of point S, (x', y') of point C', and $(x_{\lambda'}, y_{\lambda'})$ of point S'.

$$p_e = \frac{x - x_n}{x_\lambda - x_n} = \frac{y - y_n}{y_\lambda - y_n}$$

$$p_{e'} = \frac{x' - x_n}{x_{\lambda'} - x_n} = \frac{y' - y_n}{y_{\lambda'} - y_n}$$

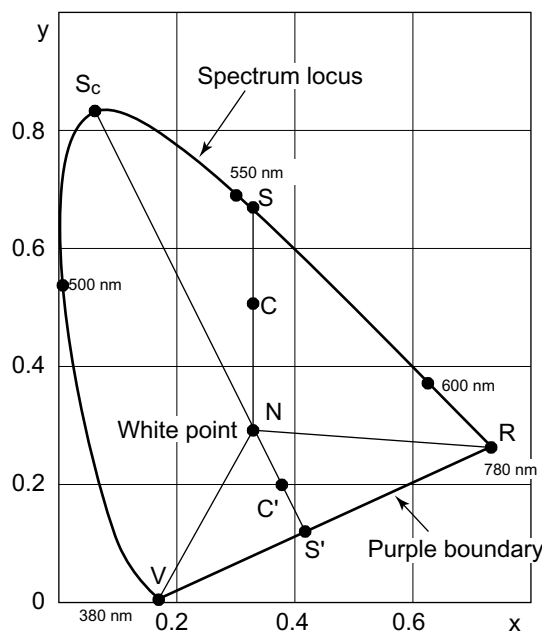

Dominant wavelength in chromaticity diagram

Outer Dimensions

(Unit: mm)

*When standard lens and lens hood are placed

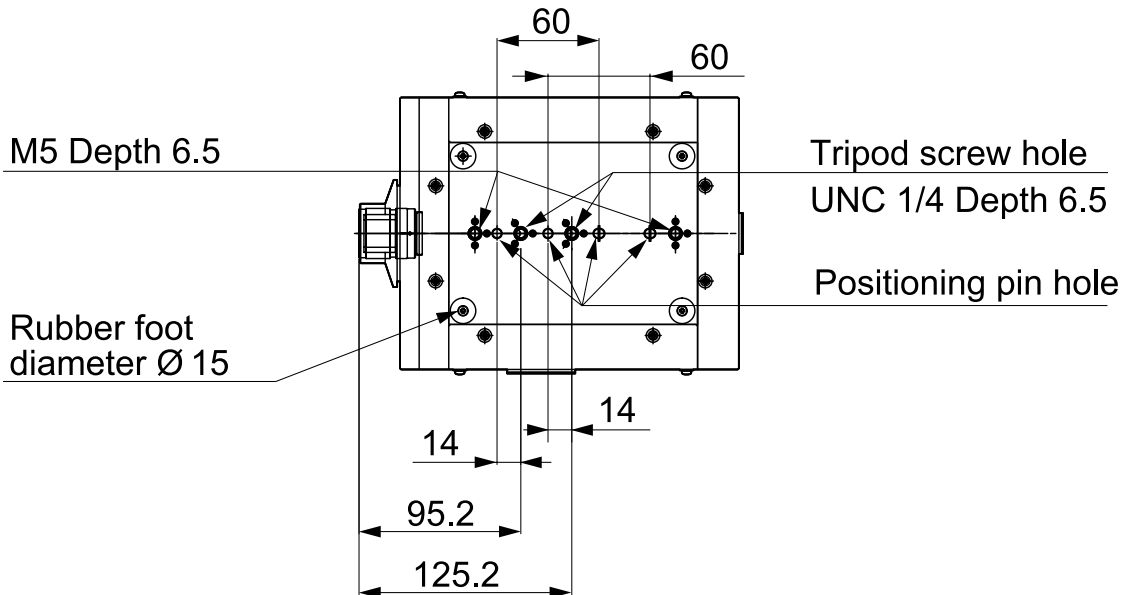
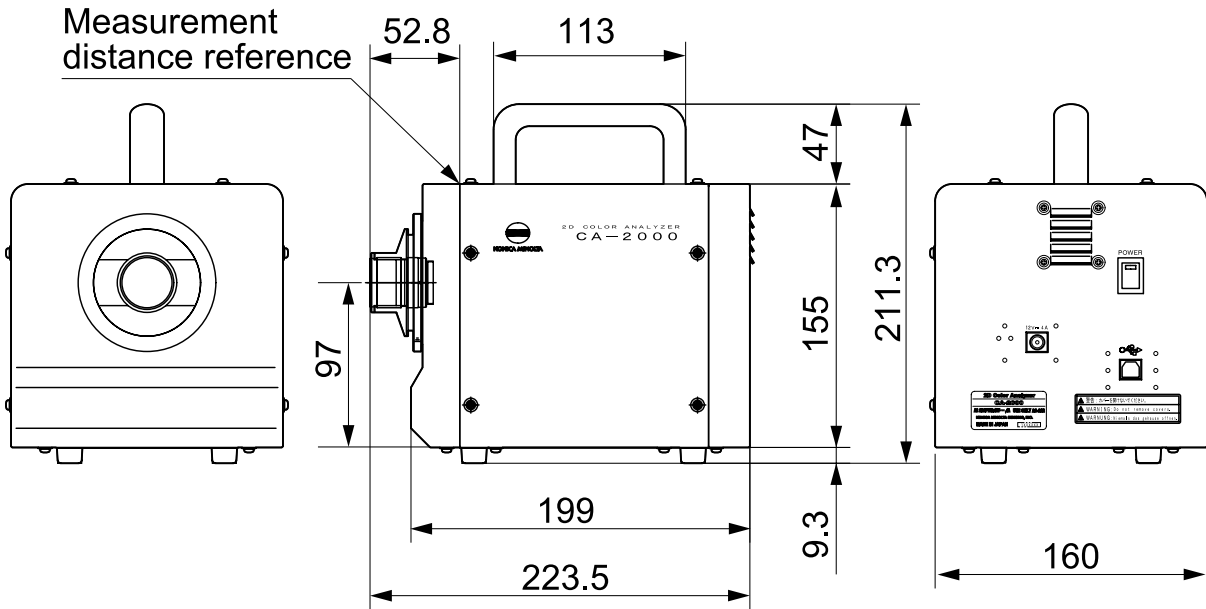

Description

Error Check

Should error be found in this instrument, try corrective actions shown in the following table. If this does not help, this instrument has possibly been broken. Please contact the nearest KONICA MINOLTA SENSING authorized service facility with indicated error number.

Error No.	Symptom	Item to Check	Corrective Action	Page to Refer
1	Power does not turn on. Does not normally start up.	Has AC adapter been plugged in outlet?	Connect AC adapter.	18
		Has AC adapter been connected with body?	Connect AC adapter.	18
		Have you connected correct AC adapter?	Use our specified standard accessory AC adapter and power cord or optionally offered AC adapter AC-A22.	6
		Is the AC power within rating?	Be sure the AC power is within $\pm 10\%$ of the nominal voltage.	-
2	Time for machine initialization after switched on varies.	It could vary depending on the machine position when switched on. It should not be regarded as failure if it takes only a few seconds.	If long time is needed, switch power off and contact the nearest KONICA MINOLTA SENSING authorized service facility.	-
3	Fan does not run after switched on.	Can hear sound if fan normally rotates.	If not, switch power off and contact the nearest KONICA MINOLTA SENSING authorized service facility.	-
4	PC cannot communicate with CA-2000.	Check whether PC correctly recognizes CA-2000.	PC could not properly recognize this instrument depending on PC type or how CA-2000 was started up. Restart PC, software, and CA-2000 according to each instruction.	23
		Check whether device driver normally operates with device driver manager.	If not, uninstall software once for reinstallation. See the instruction manual for CA-S20w.	-
		Has USB cable been connected securely?	Connect this instrument and PC securely.	19
		Check the standard for USB.	Cannot use with those supporting except for USB2.0. Use PC with which USB2.0 is usable.	19

Error No.	Symptom	Item to Check	Corrective Action	Page to Refer
5	Takes much time for measurement.	Check multiplication number.	The higher set number is, the better repeatability is, but the longer measurement it takes. To cut measurement time rather than better repeatability, set fewer number for multiplication. See the instruction manual for CA-S20w.	-
		Is the object of low luminance?	If so, shutter speed becomes slow needing longer measurement time. This should not be regarded as failure, but just accumulates weak light for measurement with appropriate light intensity. If low luminance object is measured with higher multiplication number, it takes consumable time for measurement. Set lower number for shorter measurement. See the instruction manual for CA-S20w.	-
6	Abnormal data indicated.	Has any foreign object adhered to lens or lens mount filter?	Wipe these objects off with soft and clean cloth.	3
		Have you shut off outside light?	Shut light off lest measurement area be exposed to outside light.	-
		Hasn't fluor lump reflected on measurement object?	Shut light off to prevent light reflection on measurement object. Just a little light emission, leakage, or reflection severely affects low luminance surface measurement especially.	-
		Is there any unexpected light emission?	Look at measurement object closely. Just a little light emission, leakage, or reflection severely affects low luminance surface measurement especially.	-
		Haven't you used lens other than supplied?	Use those supplied.	6
		Haven't you used lens with different serial number.	Use the lens of which serial number is identical to instrument.	17
		Have you selected correct lens type?	Select the type of using lens. See the instruction manual for CA-S20w.	24-25
		Has the lens focus position been correct?	Set correct focus position information in software for the usage condition. See the instruction manual for CA-S20w.	25-27
		Is the light exposure adequate?	In case of manual exposure mode, select appropriate exposure.	-
		Check for luminance unit, user calibration and backlight cancellation.	Set adequately depending on the purpose. See the instruction manual for CA-S20w.	-

Error No.	Symptom	Item to Check	Corrective Action	Page to Refer
7	Pattern-like unevenness appears.	Check whether stripe-like unevenness fluctuates by slightly changing the distance between CA-2000 and measurement object.	If so, Moire fringes could have generated. Adjust the measurement distance of object to reduce such phenomenon.	-
		Is it round striped pattern? Check whether pattern position does not shift even after slight migration of field angle of CA-2000 and measurement object up to down or right to left.	If not, it should not be regarded as failure, but just unique pattern of this instrument. CA-2000 shows just slight pattern-like unevenness originally. Apply lower display tone. See the instruction manual for CA-S20w.	-
8	Measurement values vary quite largely. Image looks rough.	Has the light exposure been adequate?	If light exposure is not enough under manual exposure, fluctuation of measurement values tends to be large. Set light intensity as large as possible, but so as not to overexpose.	-
		Check whether the luminance has been low.	If it is close to the limit, noise from obtained image signal becomes larger which generates uneven values or rough image, but this is not failure.	-
		Check whether the multiplication has been set low.	The lower multiplication is, the shorter measurement time is, but values tend to be more variant and image rougher. To reduce such variance rather than to pursue shorter measurement, set multiplication as high as possible. See the instruction manual for CA-S20w.	-
9	User calibration has not been functioned as expected.	Check whether the coefficient has been correct.	Select appropriate method and coefficient depending on purpose. See the instruction manual for CA-S20w.	-
10	Backlight cancellation does not work correctly.	Check whether the backlight data has been correct.	Apply backlight cancellation data corresponding to the backlight to use. See the instruction manual for CA-S20w.	-
		Check whether the backlight position has not been shifted.	If the position and size (distance) has been changed in measurement screen, take backlight data again.	-
11	Small pixel number for data. (Fewer than 980 x 980 pixels.)	Check data process range. Pixel number tends to be smaller if set up to process specified range data of all measurement area.	Set measurement range properly according to purpose and condition. See the instruction manual for CA-S20w.	-
		Check resolution condition. Resolution can be selected among 3 types; 980x980, 490x490 and 196x196 pixels. 490x490 pixels are set at shipment.	Set the resolution properly according to purpose and condition. See the instruction manual for CA-S20w.	-

Main Specification

Model	CA-2000S	CA-2000W	CA-2000T		
Light receptor	CCD image sensor (monochrome); 2/3-inch; Effective number of pixels: 1,000 x 1,000 pixels; Equipped with XYZ filter (closely matches CIE 1931 color-matching function) and ND filter				
Lens	Interchangeable Standard, wide, and telephoto lenses; low-magnification and high-magnification macro rings (for use with telephoto lens)				
Measurement points	980×980 (Available to select 490×490 or 196×196 by using Data Management Software CA-S20w.)				
Color indication modes	XYZ, L _v X _y , L _v u'v', TΔuv, Dominant wavelength, Excitation purity, L _v contrast				
Display modes	Pseudo color, RGB image, 3D graph, Chromaticity diagram, Multi point display, Cross section, Nonuniformity highlighting, Histogram				
Measurement sizes (length per side of square)*1	Standard lens	Wide lens	Telephoto lens	With low-magnification macro ring	With high-magnification macro ring
	Approx. 98 mm or more (depending on the distance)	Approx. 145 mm or more (depending on the distance)	Approx. 115 mm or more (depending on the distance)	Approx. 57 mm (Fixed)	Approx. 27 mm (Fixed)
Measurement size for typical measurement distances	98 mm/250 mm Approx.	145 mm/200 mm Approx.	115 mm/900 mm Approx.	57 mm/500 mm Approx. (Fixed)	27 mm/300 mm Approx. (Fixed)
	210 mm/500 mm Approx.	410 mm/500 mm Approx.	275 mm/2,000 mm Approx.		
	440 mm/1,000 mm Approx.	850 mm/1,000 mm Approx.	420 mm/3,000 mm Approx.		
	890 mm/2,000 mm Approx.	1,770 mm/2,000 mm Approx.			
Measurement luminance range (including ND filter use)	0.1-100,000 cd/m ²	0.1-100,000 cd/m ²	0.5-100,000 cd/m ²	0.5-100,000 cd/m ²	1-100,000 cd/m ²
Measurement time (*2)	Single : Approx. 5 sec. or more; 4-time integration: Approx. 6 sec. or more; 16-time integration: Approx. 10 sec. or more; 64-time integration : Approx. 28 sec. or more; 256-time integration : Approx. 98 sec. or more				
Accuracy (*3)	Luminance	±3 %	±3 %	±3 %	±3 %
	Chromaticity	±0.005	±0.005	±0.005	±0.005
	Temperature/humidity characteristics (within the operating temperature/humidity range) Luminance: ±2% of change compared to reference temperature and relative humidity of 23°C and 40% Chromaticity: ±0.004 of change compared to reference temperature and relative humidity of 23°C and 40%				
Repeatability (*4)	Luminance	0.5 %	0.5 %	0.5 %	0.5 %
	Chromaticity	0.001	0.001	0.001	0.001
Inter-point error (*5)	Luminance (*6)	±2 %	±2 %	±2 %	±2 %
	Chromaticity (*6)	±0.002	±0.002	±0.002	±0.002
	Luminance (*7)	±3 %	±3 %	±3 %	±3 %
	Chromaticity (*7)	±0.003	±0.003	±0.003	±0.003
Other functions	Interval measurement, Measurement sync (Synchronization frequency selectable), Integration function, Enhanced nonuniformity display, Conversion of enhanced nonuniformity image into numerical values (statistical values, etc.)				
Interface	USB 2.0				
Operating temperature and humidity range (*8)	10-30°C, Relative humidity 70% or less/No condensation				
Storage temperature and humidity range (*8)	0-30°C, Relative humidity 70% or less/No condensation 30-30°C, Relative humidity 55% or less/No condensation				
Size	Body only	160 (W) × 164 (H) × 199 (D) mm (Height including handle: 211 mm)			
	When lens and hood are attached	224 (D) mm	219 (D) mm	224 (D) mm	230 (D) mm
Weight	3.5 Kg approx. (when standard lens and hood are attached)				
Power source	Exclusive AC adapter (100 - 240 V~, 1.2 A, 50-60 Hz)				
Standard accessories	Lens Hood	CA-A68	CA-A69	CA-A68	CA-A70
	Hood Cap	CA-A71	CA-A75	CA-A71	
	Calibration data DVD	Included with each lens.			
	Other	Mount Cover CA-A61, AC Adapter AC-A22, AC cable, USB Cable IF-A18, Data Management Software CA-S20w			
Optional accessories	Soft Case CA-A60, Tripod CS-A3, Pan Head CS-A4, Calibration certificate				

*1: Error in angle of view: 7%

*2: Measurement time differs depending on brightness of measurement object, PC performance, and data processing contents. The specifications above were obtained under Konica Minolta's measurement conditions shown below:

PC CPU : Pentium 4, 2.8GHz
 Data processing : Pseudocolor display of luminance data
 Resolution : 490 x 490
 Shutter speed : Y measurement: 1/64 sec., XZ measurement: 1/32 sec.

Measurement

subject brightness : Standard/wide lens: Approx. 80 cd/m², Telephoto lens: Approx. 300 cd/m²
 Low-magnification macro ring and telephoto lens: Approx. 400 cd/m², High-magnification macro ring and telephoto lens: Approx. 600 cd/m²

* The measurement time becomes longer when the object is dark. The longest measurement time is approx. 10 seconds with 1-time integration, approx. 27 seconds with 4-time integration, approx. 95 seconds with 16-time integration, approx. 6 minutes and 8 seconds with 64-time integration and approx. 24 minutes and 19 seconds with 256-time integration

*3: The specifications above were obtained under Konica Minolta's measurement conditions shown below:

Measurement

subject brightness : Standard/wide lens: Approx. 35 cd/m², Telephoto lens: Approx. 140 cd/m²
 Low-magnification macro ring and telephoto lens: Approx. 250 cd/m², High-magnification macro ring and telephoto lens: Approx. 250 cd/m²

Distance : Minimum distance of each lens

Evaluation : Based on the average obtained within 10% range at the center of the screen

Temperature : 23°C±2°C

Relative humidity : 40%±10%

Measuring light : White, reference light source

Integration : 64 times (Normal mode)

*4: The specifications above were obtained under Konica Minolta's measurement conditions shown below:

Resolution : 196 x 196

Shutter speed : Y measurement: 1/64 sec., XZ measurement: 1/32 sec.

Gain : Normal (x1)

Light intensity level : Midpoint of appropriate light intensity range

Evaluation : Based on the maximum repeatability (2□) of all pixels

Temperature : 23°C±2°C

Relative humidity : 40%±10%

Measuring subject : White, reference light source

Integration : 64 times (Normal mode)

*5: The specifications above were obtained under Konica Minolta's measurement conditions shown below:

Measurement

subject brightness : Standard/wide lens: Approx. 40 cd/m², Telephoto lens: Approx. 160 cd/m²

Low-magnification macro ring and telephoto lens: Approx. 200 cd/m², High-magnification macro ring and telephoto lens: Approx. 350 cd/m²

Distance : Calibration distance of each lens

Resolution : 196 x 196

Evaluation (*6) : Based on the maximum/minimum values obtained in a square at the center of the screen measuring 60% of the height and width of the entire screen

(*7) : Based on the maximum/minimum values obtained in the entire screen

Temperature : 23°C±2°C

Relative humidity : 40%±10%

Measurement subject: White, reference light source

Integration : 64 times (Normal mode)

*8: Even if the instrument is stored within the specified usage (or storage) temperature humidity range, the displayed value may change depending on long-period usage or storage conditions.

If you have any questions about specifications, please contact your Konica Minolta representative.

The specifications given here are subject to change without prior notice.



KONICA MINOLTA