

CR-410F French Fry Package

The Right **Color** for French Fries



What is a CR-410F?

The CR-410F is a precise colorimeter that can be used to measure the color of cooked French Fries. Currently, cooked fries are either evaluated visually for color or they are measured by a bulky & expensive instrument. The CR-410F can be used to measure the color of fried potatoes and will display a number, an index value, calculated to correlate to industry standard measurements. The CR-410F series instrument is based on Konica Minolta's CR-400 instrument technology, a highly accurate and reliable platform that has been in service to the food industry for over 20 years.

What makes the CR-410F different than currently available instruments?

Advantages:

- Portability-Measurements can be taken on the production floor
- Lower cost, up to 50% less expensive than competitive instruments.
- Improved accuracy over competitive models.
- Measures color in the visible range, as people see it.
Competitive instruments do not.

How can the CR-410F help the industry?

The CR-410F is very accurate and repeatable. The CR-410F boasts one of the best inter instrument agreement specifications in the industry. That means if you are correlating data with other locations or using multiple instruments you can be assured the numbers match instrument to instrument, location to location.

The lower initial cost of ownership of CR-410F coupled with its high accuracy gives companies the ability to access a first class measurement solution economically.

The total cost of ownership including service is substantially lower than competitive models.

What are the key features/benefits to the customer?

- Ease of use
- More affordable than competitive instruments.
- Portable/Handheld
- CR-410P has lower maintenance costs than competitive models.
- Can interface with PC color data software such as SpectraMagic NX.

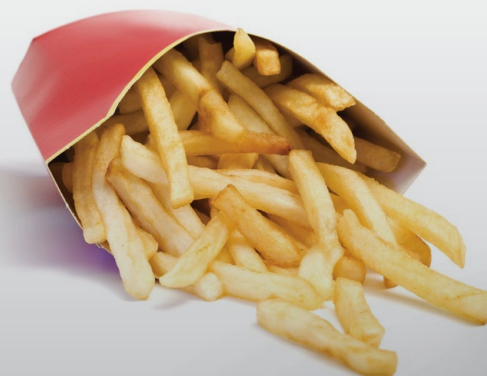

SpectraMagic™ NX *(optional)*

Supports Windows®2000/XP/Vista

SpectraMagic™ NX enables you to perform comprehensive color inspection and analysis of incoming raw materials, in process production, and outbound color critical goods and materials in virtually any industry. With SpectraMagic™ NX you can insert digital images with measured data. Measure samples in any of 8 universally accepted color spaces. Select from 15 illuminants, and up to 40 indices to determine specific color and appearance properties, such as strength, brightness, haze, yellowness, opacity, and strength. You can even configure up to 3 customized color equations. Reports range from simple Pass/Fail to trend charts, histograms, color plots, and spectral graphs. SpectraMagic™ NX comes with predefined templates using skin technology, or you can create your own templates. For illustrations and explanations to understanding color and color measurement technology, there is a link to Konica Minolta's well known and respected "Precise Color Communication."

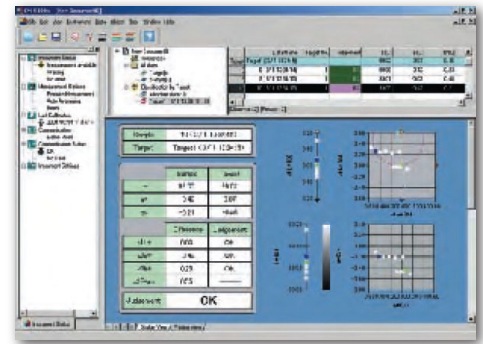

SYSTEM REQUIREMENTS

OS	Windows® 2000 Professional SP4 Windows® XP Professional SP2 Windows® Vista
CPU	Pentium® III 600 MHz or higher
Memory	128MB (256 MB recommended)
Hard Disk	450 MB of available disk space
Display	Graphic card capable of displaying 1024x768/High Color (16-bit)
Other	CD-ROM drive (required for installation) One free USB port or printer port (for protection key) One free serial port (for instrument) Internet Explorer Ver. 5.01 or later

SPECIFICATIONS

Color Space	$L^*a^*b^*$, L^*C^*h , Lab99, LCh99, XYZ, Hunter Lab, Yxy, $L^*u^*v^*$, $L^*u^*v^*$, Munsell and their color differences (excluding Munsell)
Index	WI (CIE 1982, ASTM E313-73, Hunter, Berger, Taube, Stensby, Ganz), Tint(Ganz), YI (ASTM D1925-70, ASTM E313-73, ASTM E313-96, DIN6167), WB (B ASTM E313-73), Standard Depth (ISO 105.A06), RxRyRz, Gray scale (ISO 105.A05)
Color Difference Equation	ΔE^*ab (CIE 1976), ΔE^*94 (CIE 1994), $\Delta E00$ (CIE 2000), $\Delta E99$ (DIN99), ΔE (Hunter), CMC (l:c), FMC-2, NBS 100, NBS 200
Observer	2 degree
Illuminants	C, D65
Graph Display	$L^*a^*b^*$ absolute value, $\Delta L^*a^*b^*$ (color difference distribution), Hunter Lab absolute value, Hunter ΔLab (color difference distribution), Trend chart histogram of each color space and color difference equation, Pseudo Color display

CR-400T UTILITY SOFTWARE CR-S4W

- To take measurements or change the measurement parameters of the CR-410T, you can control the unit with a PC.
- Measurement data can be transferred directly to a Microsoft Excel® file by means of the OLE Function. (Excel® 97/2000/2002 is required to use the Excel® transfer function.)
- Calibration data and color-difference reference color data can be uploaded or modified.

SYSTEM REQUIREMENTS

OS	Windows® 98/2000/XP/Vista
CPU	Pentium® 166MHz or higher
Memory	128MB (256 MB recommended)
Hard Disk	32 MB or higher
Display	VGA (640x480) or higher
Resolution	

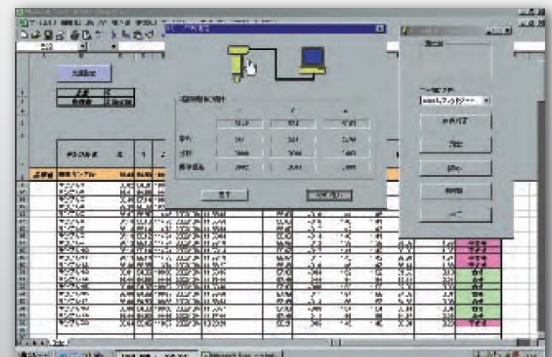

Specifications

Name	Chroma Meter Measuring Head
Model	CR-410Head
Illuminating/viewing system	Wide-area illumination/0° viewing angle (Specular component included)
Detector	Silicone photo cells (6)
Display range	Y: 0.01 to 160.00% (reflectance)
Light source	Pulsed xenon lamp
Measurement time	1 seconds.
Minimum measurement interval	3 seconds.
Battery performance	Approx. 800 measurements (when using batteries under company testing Konica Minolta's conditions)
Measurement/illumination area	φ50/φ53
Repeatability	Within ΔE*ab0.07 standard deviation (when the white calibration plate is measured 30 times at intervals of 10 seconds)
Inter instrument agreement	ΔE*ab: within 0.8
Observer	Average of 12 BCRA series II colors
Illuminant *1	2 degrees Closely matches CIE 1931 Standard Observers: (x̄, ȳ, z̄)
Display *1	Chroma values, color difference values, PASS/WARN/FAIL display
Tolerance judgment *1	Color difference tolerance (box tolerance and elliptical tolerance)
Color space/ colorimetric data	XYZ, Y x y, L*a*b*, Hunter Lab, L*C*h, Munsell (only illuminant C), CMC(l:c), CIE1994, Lab99, LCh99, CIE2000, CIE WI-Tw (only illuminant Des), WI ASTM E313 (only illuminant C), YI ASTM D1925 (only illuminant C), YI ASTM E313 (only illuminant C), User index (up to six can be registered from computer)
Languages	Operating keys : English LCD : English (default) (LCD : German, French, Italian, Spanish, Japanese) *1
Storable data sets	1000 (measuring head and data processor save different data)
Color difference target colors	100
Calibration channels *1	20 channels (ch00 : white calibration, ch01 to ch19 : user calibration)
Display	Dot-matrix LCD with back light (15 chars x 9 lines + 1 line for icon display)
Interface	RS-232C compliant (for data processor/PC) * Baud rate : 4800, 9600, 19200 (bps), set at 9600 bps when shipped from factory
Power source	4 AAA size alkaline or Ni-MH batteries, AC adapter (AC-A17) AC120V ~ 50-60Hz 0.4A (for N.America and Japan) AC230V ~ 50-60Hz 0.4A (for worldwide except N.America)
Size	102(W) x 244(H) x 63(D)mm
Weight	Approx. 570g (including 4 AAA size batteries and not including RS-232C cable)
Operating temperature/humidity range	0 to 40°C, relative humidity 85% or less (at 35°C) with no condensation * Operating temperature/humidity range of products for North America : 5 to 40°C, relative humidity 80% or less (at 31°C) with no condensation
Storage temperature/humidity range	-20 to 40°C, relative humidity 85% or less (at 35°C) with no condensation
Other	LCD back light ON/OFF function (when ON, back light stays ON for 30 seconds after last key or measurement operation)
*1 indicates when connected to the Data Processor or when not set using the Data Processor or the optional software, that some of the function are not available when the measuring head is not connected.	

Dimensions

Units : mm

Measuring Head C R -4 1 0

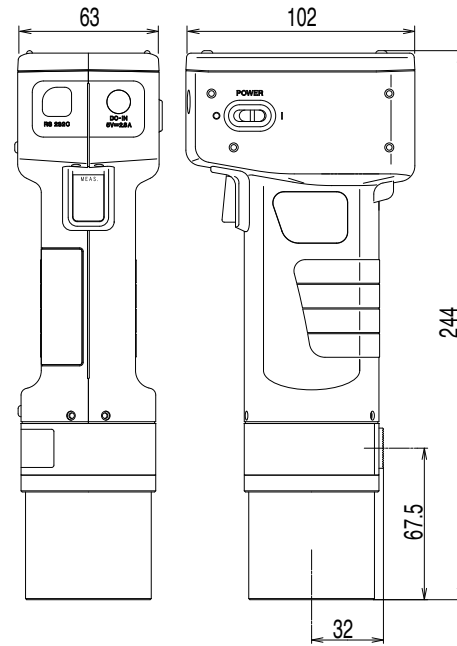

Name	Data Processor
Model	DP-400
Display range	Y : 0.01 to 160.00% (reflectance)
Measurement time *2	1 Seconds.
Minimum measurement interval *2	3 Seconds.
Battery performance	Approx. 800 measurements (when using batteries under company testing Konica Minolta's conditions)
Illuminants	C, Des
Display	Chroma values, color difference values, color difference graphs, PASS/WARN/FAIL display
Tolerance judgment *2	Color difference tolerance (box tolerance and elliptical tolerance) Only for the display function
Color space/ colorimetric data	XYZ, Y x y, L*a*b*, Hunter Lab, L*C*h, Munsell (only illuminant C), CMC (l:c), CIE1994, Lab99, LCh99, CIE2000, CIE WI-Tw (only illuminant Des), WI ASTM E313 (only illuminant C), YI ASTM D1925 (only illuminant C), YI ASTM E313 (only illuminant C), User index (up to six registered in the Measuring Head can be used)
Languages	Operating keys : English, LCD : English (default), German, French, Italian, Spanish, Japanese
Storable data sets	Max. 2000 pieces of data (divisible into 100 pages) Deletion and Undoing selected stored data (one piece of data or all data) are possible
Color difference target colors *2	Only for the operating function (100 pieces of data when the measuring head is connected; input of measurement values or numeric) (independent of page function)
Calibration channels *2	Only for the operating function (20 channels when the measuring head is connected) (ch00: white calibration; ch01 to ch19: user calibration)
Page function	100 pages
Display	Dot-matrix LCD with back light (16 chars x 9 lines + 1 line for icon display) Contrast adjustment
Printer	384 dot line thermal printer (can also print graphs) Automatically prints out all measurement results (can be set not to print)
Statistical function	Maximum, minimum, average, and standard deviation
Automatic measurement *2	Date and time display: year, month, day, hour, minute Timer: 3seconds. to 99 minutes. (Some measurement modes require more than 3 seconds.)
Interface	RS-232C compliant Baud rate (bps) : 19200 fixed (when connected to PC) When measuring head is connected baud rate is automatically set to that of the measurement head
Power source	4 AA size alkaline or Ni-MH batteries, AC adapter (AC-A17) AC120V ~ 50-60Hz 0.4A (for N.America and Japan) AC230V ~ 50-60Hz 0.4A (for worldwide except N.America)
Size	100(W) x 73(H) x 255(D)mm
Weight	Approx. 600g (not including batteries and paper)
Operating temperature/humidity range	0 to 40°C, relative humidity 85% or less (at 35°C) with no condensation * Operating temperature/humidity range of products for North America : 5 to 40°C, relative humidity 80% or less (at 31°C) with no condensation
Storage temperature/humidity range	-20 to 40°C, relative humidity 85% or less (at 35°C) with no condensation
Other	User calibration function (multi-calibration/manual calibration) *2, Measurements for automatic average function, Print ON/OFF function, CR-400 measurement data import function *2, All color space print ON/OFF function, Data protection ON/OFF function, Back light ON/OFF function, Buzzer ON/OFF function, Display color limit function, Remote mode (stored data output), Character input function (alphanumeric)
*2 indicates that part of or all functions are not available when the measurement head is not connected.	

Data Processor DP -4 0 0 (optional)

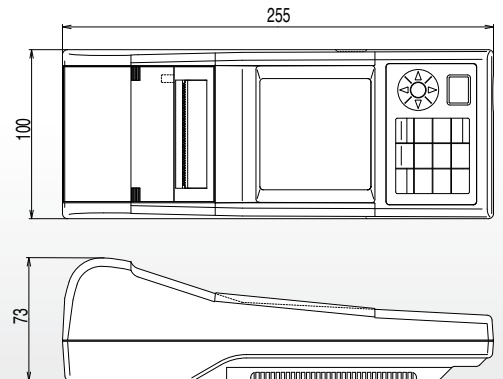

SAFETY PRECAUTIONS

For correct use and for your safety, be sure to read the instruction manual before using the instrument.

- Always connect the instrument to the specified power supply voltage. Improper connection may cause a fire or electric shock.