

NON-CONTACT 3D DIGITIZER

VIVID 300/VI-300

INSTRUCTION MANUAL (HARDWARE)

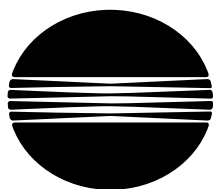

MINOLTA

Safety Symbols

The following symbols are used in this manual to prevent accidents which may occur as result of incorrect use of the instrument.



Denotes a sentence regarding safety warning or note.
Read the sentence carefully to ensure safe and correct use.



Denotes a prohibited operation.
The operation must never been performed.



Denotes an instruction.
The instruction must be strictly adhered to.



Denotes an instruction.
Disconnect the AC power cord from the AC outlet.



Denotes a prohibited operation.
The part must never be disassembled.

















Denotes a sentence regarding safety precaution for laser.
Read the sentence carefully to ensure safe and correct use.









Denotes an instruction.
Connect the grounding terminal as instructed.

SAFETY PRECAUTIONS

- To ensure correct use of the VIVID 300, read the following points carefully and adhere to them. After you have read this manual, keep it in a safe place where it can be referred to anytime a question arises.

 WARNING (Failure to adhere to the following points may result in death or serious injury.)	
 Do not use the VIVID 300 in places where flammable or combustible gases (gasoline etc.) are present. Doing so may cause a fire.	 Do not disassemble or modify the VIVID 300. Doing so may cause a fire or electric shock.
 Always use the AC power cord supplied as a standard accessory with the VIVID 300, and connect it to an AC outlet (100-240 Vac, 50-60 Hz). Failure to do so may damage the VIVID 300, causing a fire or electric shock.	 Take special care not to allow liquid or metal objects to enter the VIVID 300. Doing so may cause a fire or electric shock. Should liquid or metal objects enter the VIVID 300, turn the power OFF immediately, disconnect the AC power cord from the AC outlet, and contact the nearest Minolta-authorized service facility.
 Do not bend, twist or pull the AC power cord excessively. In addition, do not place heavy items on the AC power cord, or damage or modify it in any way. Doing so may cause damage to the AC power cord, resulting in fire or electric shock.	 The VIVID 300 should not be operated if dirt or dust has entered through the vent holes. Doing so may result in a fire. For periodic inspection, contact the nearest Minolta-authorized service facility.
 If the VIVID 300 will not be used for a long time, disconnect the AC power cord from the AC outlet. Accumulated dirt or water on the prongs of the AC power cord's plug may cause a fire. If there is any dirt or water on the prongs of the AC power cord's plug, remove it.	 Never stare into the laser emitting window. 
 When disconnecting the AC power cord's plug, always hold the plug and pull it to remove it. Never pull the AC power cord itself. Doing so may damage the AC power cord, causing a fire or electric shock. In addition, do not insert or disconnect the AC power cord's plug with wet hands. Doing so may cause electric shock.	 Do not place a lens, mirror or optical element in the passage of the laser beam. Doing so may converge the laser beam, resulting in damage to your eyes, burns or fire. To prevent the above accidents, make sure that a wall or similar which can block the laser beam is located behind the object. 
 The VIVID 300 should not be operated if it is damaged, or smoke or odd smells are detected. Doing so may result in a fire. In such situations, turn the power OFF immediately, disconnect the AC power cord from the AC outlet, and contact the nearest Minolta-authorized service facility.	

 CAUTION (Falling to adhere to the following points may result in injury or damage to the VIVID 300 or other property.)	
 For Continued protection against risk of fire or electrical shock a mains plug shall connect to grounding-type socket outlet.	 When replacing the fuse, first turn the power OFF, disconnect the AC power cord from the AC outlet, then replace it with one which conforms to the required specifications. If the fuse blows off soon after it has been replaced, contact the nearest Minolta-authorized service facility.
 Before connecting the grounding terminal, make sure that the AC power cord is not connected to the AC outlet. Failure to do observe this may cause electric shock.	 The socket-outlet shall be installed near the machine and shall be easily accessible.
 Do not place the VIVID 300 on an unstable or sloping surface. Doing so may result in its dropping or overturning, causing injury. Take care not to drop the VIVID 300 when carrying it.	

FOREWORD

The VIVID 300 (for non-Europe)/VI-300 (for Europe) is designed for non-contact acquisition of 3D image data of an object by emitting a laser beam to the object and acquiring its shading images.
Please note that the VIVID 300 model name is intended only for reference with this manual.

NOTES ON USE

- △ This instrument should be used under the following environmental conditions:
 - Indoor use only
 - Maximum altitude: 2000 m
 - Ambient temperature: 10 to 35°C
 - Humidity: Less than relative humidity of 85% (at 35°C) with no condensation
 - Allowable fluctuation of power supply voltage: $\pm 10\%$ of nominal voltage
 - Installation category II
 - Pollution degree 1
- △ Do not use the VIVID 300 in direct sunlight or near sources of heat such as stoves. Doing so will cause the temperature of the VIVID 300 to rise considerably higher than room temperature and may result in malfunctions. Use the VIVID 300 in a well ventilated area and make sure that the ventilation holes of the VIVID 300 are not blocked.
- △ Do not use the VIVID 300 in extremely dusty or humid areas. Doing so may result in malfunctions.
- △ Do not subject the VIVID 300 to strong vibration or shocks. Doing so may result in malfunctions.
- △ Do not disconnect cords and cables with the POWER switch of the VIVID 300 set to ON "I". Doing so may result in malfunctions.
- △ This equipment has been tested and found to comply with the limits for a Class B digital device, pursuant to Part 15 of the FCC Rules. These limits are designed to provide reasonable protection against harmful interference in a residential installation. This equipment generates, uses and can radiate radio frequency energy and, if not installed and used in accordance with the instructions, may cause harmful interference to radio communications. However, there is no guarantee that interference will not occur in a particular installation. If this equipment does cause harmful interference to radio or television reception, which can be determined by turning the equipment off and on, the user is encouraged to try to correct the interference by one or more of the following measures:
 - Reorient or relocate the receiving antenna.
 - Increase the separation between the equipment and receiver.
 - Connect the equipment into an outlet on a circuit different from that to which the receiver is connected.
 - Consult the dealer or an experienced radio/TV technician for help.
- △ This Class B digital apparatus meets all requirements of the Canadian (ICES-003).
Cet appareil numérique de la classe B est conforme à la norme NMB-003 du Canada.
- △ The VIVID 300 is a class I instrument specified in IEC Publication 60825-1:1993/Amd.1:1997. Use it according to the instructions given in this manual.

CARE AND STORAGE

- △ The VIVID 300 should be stored in areas with temperatures of between -20 and +50°C. Do not store it in areas subject to high temperature or high humidity or where sudden changes in temperature or condensation are likely to occur. We recommend storing the VIVID 300 at a relatively constant temperature with a desiccant (silica gel etc.).
- △ Do not leave the VIVID 300 inside a closed car or in the trunk of a car. Under direct sunlight, the increase in temperature can be extreme and may result in malfunctions.
- If the VIVID 300 needs cleaning, wipe with a soft dry cloth. Never use solvents such as thinner or benzene.
- In cases of malfunction, do not disassemble the VIVID 300 or attempt to repair it yourself. Contact the nearest Minolta-authorized service facility.

Company names and product names which appear in this manual are their trademarks or registered trademarks.

CONTENTS

SAFETY PRECAUTIONS	1
ACCESSORIES	4
STANDARD ACCESSORIES	4
OPTIONAL ACCESSORIES.....	4
SYSTEM CONFIGURATION	5
NAMES OF PARTS	6
CONNECTING THE AC POWER CORD	7
CONNECTING THE VIVID 300 TO A HOST COMPUTER	8
MAKING SCSI SETTING.....	9
Setting the DIP Switch (SCSI ID)	9
Setting the SCSI ID No.	9
Setting the Terminator.....	10
Turning ON/OFF the Power to the Terminator	10
TURNING POWER ON/OFF.....	11
CONNECTING AN EXTERNAL MONITOR.....	12
Replacing the Fuse.....	13
MEASURING PRINCIPLE	14
High-Speed Image Processing Circuit.....	14
DIMENSION DIAGRAM	15
SPECIFICATIONS	16

ACCESSORIES

Check that the following standard accessories are present.

VIVID 300 MAIN BODY

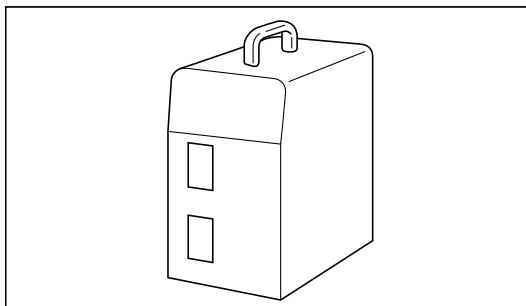

STANDARD ACCESSORIES

AC POWER CORD

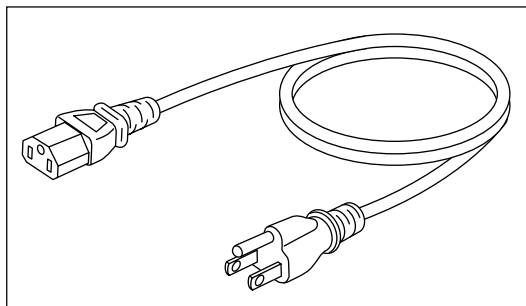

UTILITY SOFTWARE VI-S1

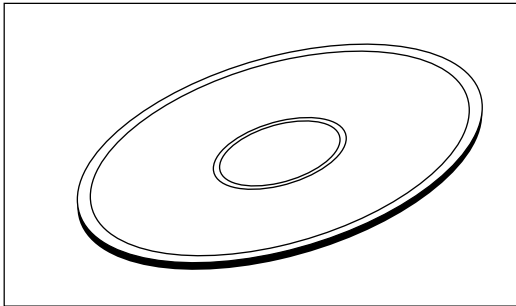

OPTIONAL ACCESSORIES

The following are optional items, so they must be purchased if needed.

ROTATING STAGE SET

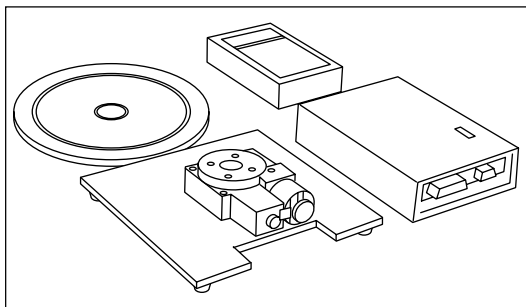

PANHEAD CS-A4

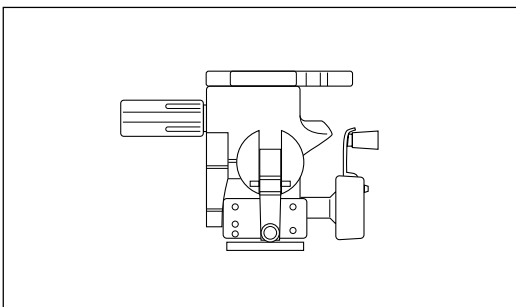

TRIPOD CS-A3

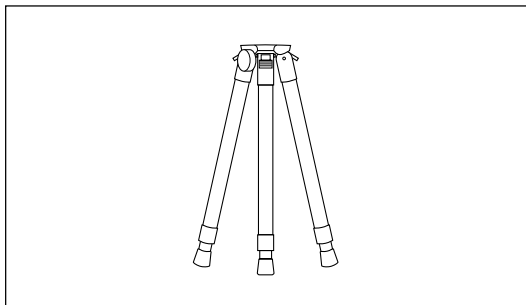

SCSI Cable VI-A20 (Half-pitch, D-Sub, 50-pin male plug on both ends)

Joint MM-A14 (for rotating stage)

SCSI Conversion Connector: VI-A21 (50-pin female ↔ 68-pin male)

SYSTEM CONFIGURATION

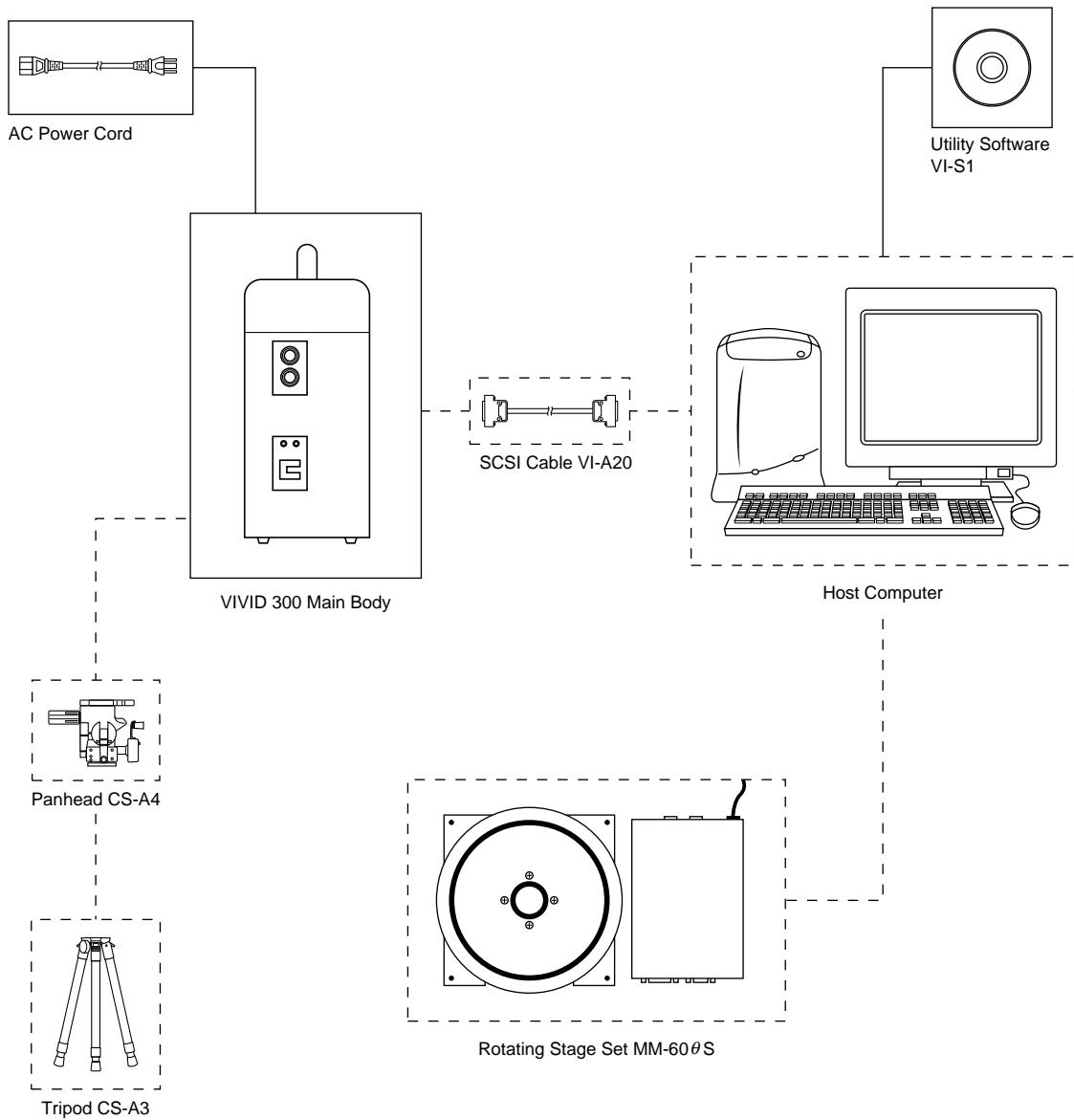

———— Standard accessory

- - - - Optional accessory
 (A commercially available
 computer can be used as
 the host computer.)

NAMES OF PARTS

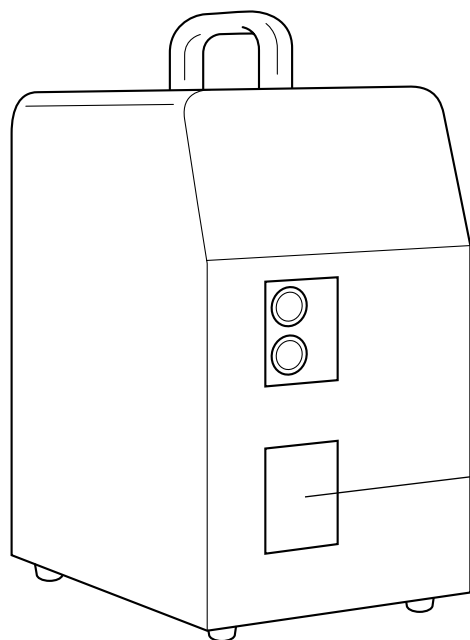

Laser Emitting Window
A laser beam is emitted from this window.
Do not stare into this window.

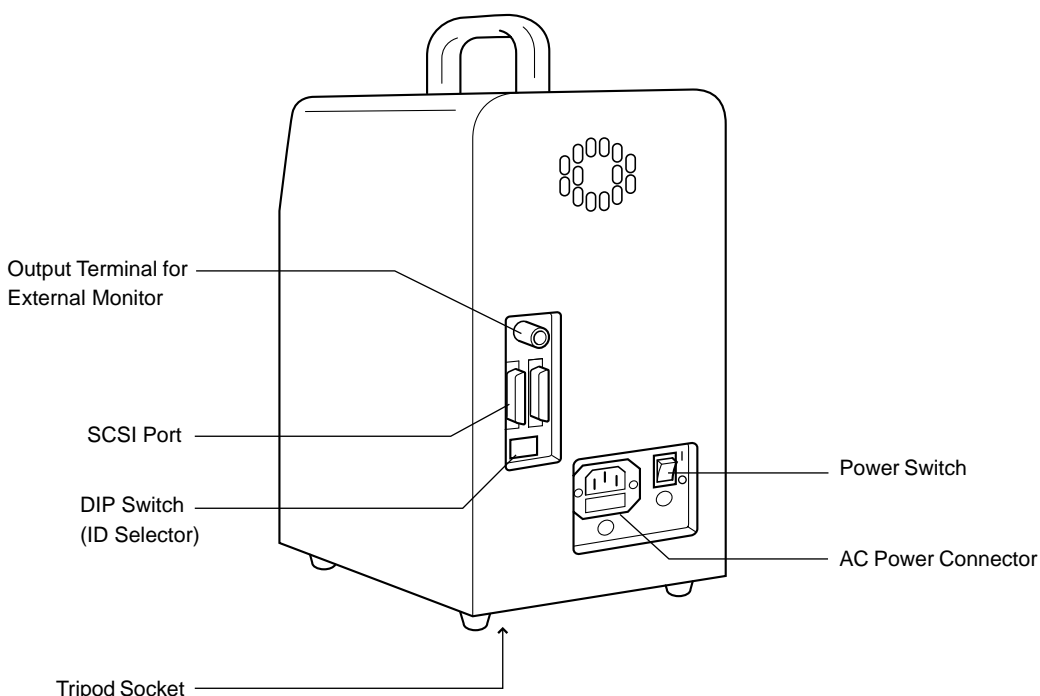

CONNECTING THE AC POWER CORD

⚠ WARNING

- ❗ Always use the AC power cord supplied as a standard accessory with the VIVID 300, and connect it to an AC outlet (100-240 V~, 50-60 Hz). Failure to do so may damage the VIVID 300, causing a fire or electric shock.
- ⚡ Do not bend, twist or pull the AC power cord excessively. Do not place heavy items on the AC power cord, or damage or modify it in any way. Doing so may cause damage to the AC power cord, resulting in fire or electric shock.
- 🧼 If the VIVID 300 will not be used for a long time, disconnect the AC power cord from the AC outlet. Accumulated dirt or water on the prongs of the AC power cord's plug may cause a fire. Any dirt or water on the prongs of the AC power cord's plug must be removed.
- ❗ When disconnecting the AC power cord's plug, always hold the plug and pull it to remove it. Never pull the AC power cord itself. Doing so may damage the AC power cord, causing a fire or electric shock. Do not insert or disconnect the AC power cord's plug with wet hands. Doing so may cause electric shock.

⚠ CAUTION

- 🔌 For Continued protection against risk of fire or electrical shock a mains plug shall connect to grounding-type socket outlet.
- ❗ Before connecting the grounding terminal, make sure that the AC power cord is not connected to the AC outlet. Failure to observe this may cause electric shock.
- 🔌 The socket-outlet shall be installed near the machine and shall be easily accessible.

Connecting Method

1. Set the POWER switch on the side panel of the VIVID 300 to the OFF "O".

⚠ If the AC power cord is connected to an AC outlet with the POWER switch set to ON "I", damage to the VIVID 300 or host computer may result.

2. Plug the AC power cord to the AC power connector (AC IN) on the side panel.
3. Plug the other end of the AC power cord to an AC outlet.

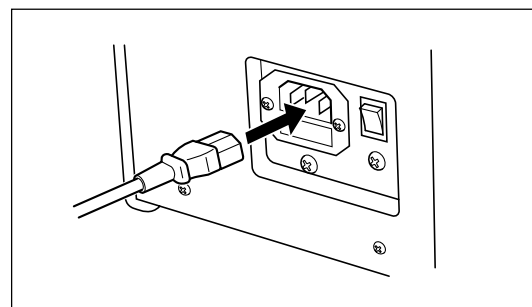
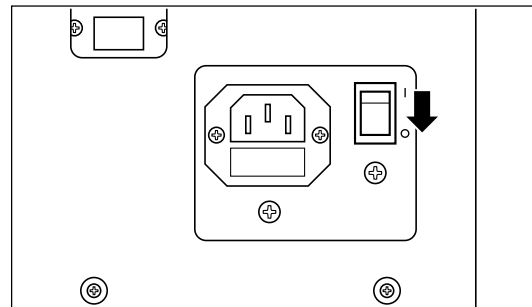

CONNECTING THE VIVID 300 TO A HOST COMPUTER

The VIVID 300 is designed to be operated from a host computer using utility software. Before operating the VIVID 300, make sure that it is connected to the host computer with an optional SCSI cable.

⚠ CAUTION

- The host computer must be operated correctly and safely according to its instruction manual.
- The optional SCSI cable (VI-A20) has a 50-pin male plug (half-pitch, D-Sub) on both its ends.
- Before turning the host computer ON, make sure that the VIVID 300 is turned ON and ready for operation.

Connecting Method

1. Set the POWER switch of both VIVID 300 and host computer to OFF "O".

⚠ If the VIVID 300 is connected to the host computer with the POWER switch set to ON "I", damage to the VIVID 300 or host computer may result.

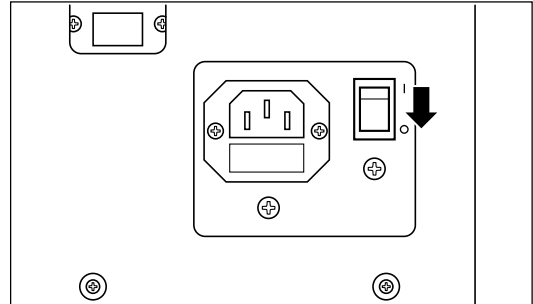

2. Plug the SCSI cable to a SCSI port of the VIVID 300.
3. Plug the other end of the SCSI cable to the SCSI connector of the host computer.

◆ The VIVID 300 is now connected to the host computer.

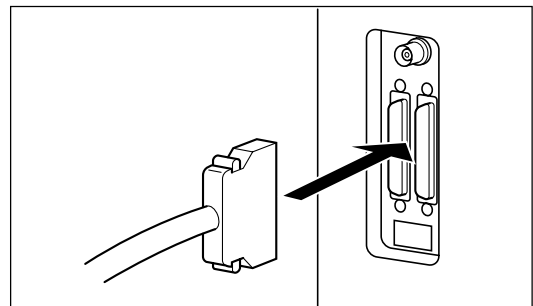

- When you select [Control Panel] – [SCSI Adapters] and then click the [Devices] tab, "Minolta VIVID700" will be displayed as the device name. Please note that "Minolta VIVID700" is displayed instead of "Minolta VIVID300".

MAKING SCSI SETTING

Make the following settings according to the SCSI settings made on the host computer and peripheral devices you are using. Once they are made, it is not necessary to make them again.

Setting the DIP Switch (SCSI ID)

DIP switches (ID selector) are provided on the rear panel for the following settings:

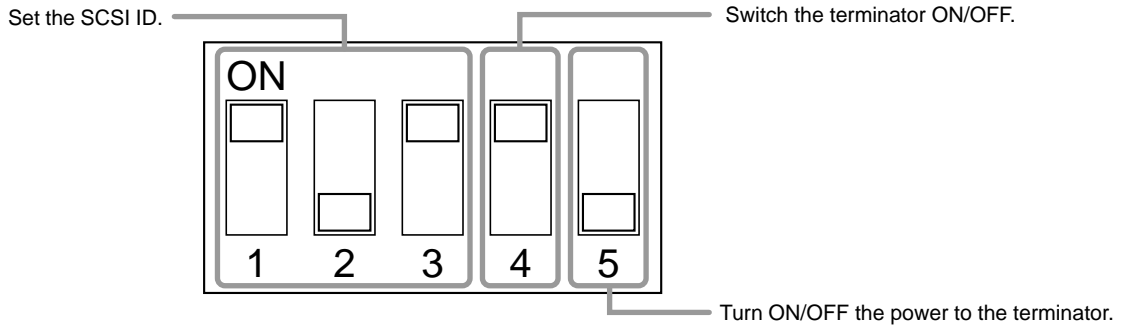

Setting the SCSI ID No.

In order for the host computer to recognize that the VIVID 300 is connected to the host computer via the SCSI interface, a SCSI ID No. (1 to 6) must be set for the VIVID 300.

- SCSI ID No. 5 has been set as the default setting before shipment.
- If other SCSI devices are connected to the host computer via the SCSI interface, make sure that the SCSI ID No. of the VIVID 300 differs from those set for the devices.

Setting Method

1. Make sure that the POWER switch of both VIVID 300 and host computer are set to OFF "○".
2. If other SCSI devices are connected to the host computer via the SCSI interface and are currently used, make sure that the SCSI ID No. of the VIVID 300 differs from those set for the devices.

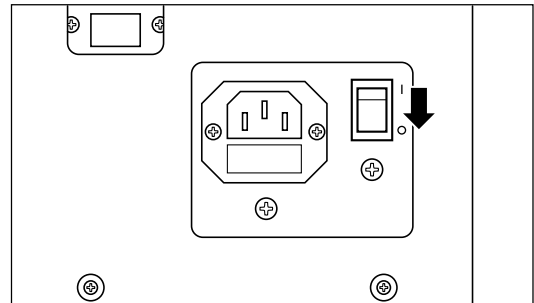

- For a description of how to check the SCSI ID, refer to the manual supplied with the SCSI interface board.
- If the currently set SCSI ID No. of the VIVID 300 is already used by other devices, proceed to the next step 3 and set a unique SCSI ID No. using the DIP switches SW1 to 3. If not, skip to step 4.

3. Refer to the table below and set a unique SCSI ID No. using the DIP switches SW1 to 3.

- If other SCSI devices are already connected to the host system via the SCSI interface, make sure that a SCSI ID No. other than those set for those devices is set.

SCSI ID	SW1	SW2	SW3
0	OFF	OFF	OFF
1	ON	OFF	OFF
2	OFF	ON	OFF
3	ON	ON	OFF
4	OFF	OFF	ON
5	ON	OFF	ON
6	OFF	ON	ON
7	ON	ON	ON

4. Use the DIP switches SW4 and SW5 to set whether the terminator is to be used or not and whether power is to be supplied to the terminator.

		SW4	SW5
Terminator	Enabled	ON	
	Disabled	OFF	
Terminator power	Supplied		ON
	Not supplied		OFF

Setting the Terminator

The VIVID 300 has a built-in SCSI terminator. The terminator is needed if the VIVID 300 is the last device of those connected in series to the SCSI interface. If only one of the SCSI ports on the VIVID 300 is used, “Enabled” or “Disabled” must be selected correctly.

- If the VIVID 300 is not the last device of those connected in series to the SCSI interface or if it is not connected via the SCSI interface, “Disabled” must be selected.
- “Enabled” has been selected as the default setting before shipment.
- ⚠ If the terminator is not set correctly, the VIVID 300 or devices connected to the SCSI interface may malfunction.

Turning ON/OFF the Power to the Terminator

SW5 is used to decide whether power is to be supplied to the terminator. For details, refer to the manual that comes with the SCSI interface board.

- Set SW5 to ON (Supplied) if you are going to connect the VIVID 300 to a Laptop computer, or set it to OFF (Not supplied) if you are going to connect the VIVID 300 to a desktop computer.

TURNING POWER ON/OFF

Turning Power ON

1. Set the POWER switch of the VIVID 300 to ON "I".
2. Set the POWER switch of the host computer to ON.

◆ The VIVID 300 is now ready for operation.

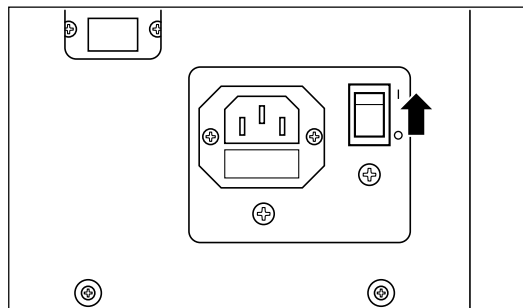

⚠ When turning the power ON after it has been turned OFF, wait at least 5 seconds before turning the power ON. Failure to do so may result in malfunction.

Turning Power OFF

1. Set the POWER switch of the host computer to OFF.
2. Set the POWER switch to OFF "O".

◆ The power will be turned off.

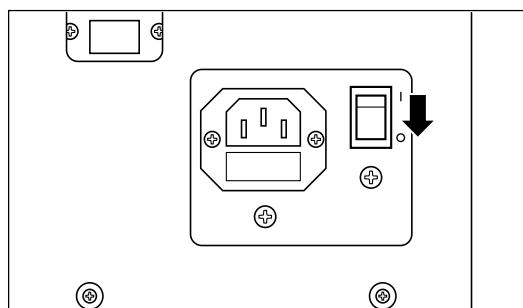

CONNECTING AN EXTERNAL MONITOR

To connect an external monitor to the VIVID 300, use a suitable co-axial cable (the cable must have a BNC terminal (75 Ω) on the end which is to be connected to the VIVID 300).

- Only the NTSC type monitor can be used (PAL and other types cannot be used).

Connecting Method

1. Set the POWER switch of both VIVID 300 and external monitor to OFF "O".

⚠ If the VIVID 300 is connected to the monitor with the POWER switch set to ON "I", damage to the VIVID 300 or monitor may result.

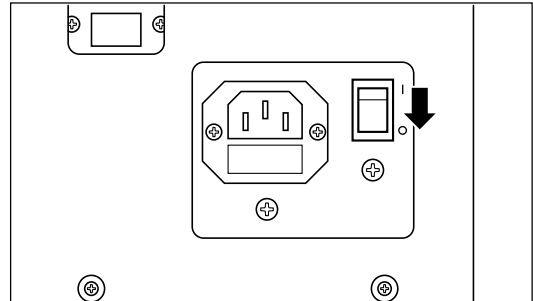

2. Connect the BNC plug of the co-axial cable to the output terminal for external monitor (MONITOR) of the VIVID 300.

3. Connect the other end of the cable to the VIDEO terminal of the external monitor.

- ◆ The VIVID 300 is now connected to the external monitor.
- Set the POWER switch of the VIVID 300 to ON "I". The same views and images currently displayed on the view-finder will appear on the external monitor.

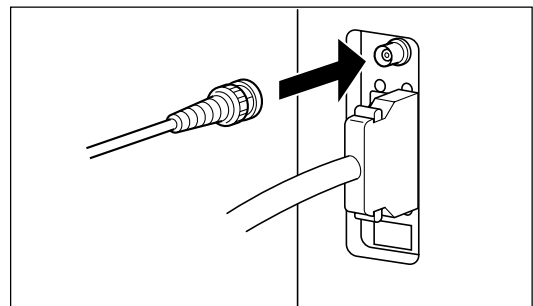

Replacing the Fuse

To prevent disaster such as fire, a fuse which conforms to the following requirements must be used.
Usable fuses T2A 250V type

WARNING

⚠ When replacing the fuse, first turn the power OFF, disconnect the AC power cord from the AC outlet, then replace it with one which conforms to the required specifications. Failure to do so may result in electric shock. If the fuse blows off soon after it has been replaced, contact the nearest Minolta-authorized service facility.

Replacement Procedure

1. Set the POWER switch to OFF, then disconnect the AC power cord from the AC outlet.

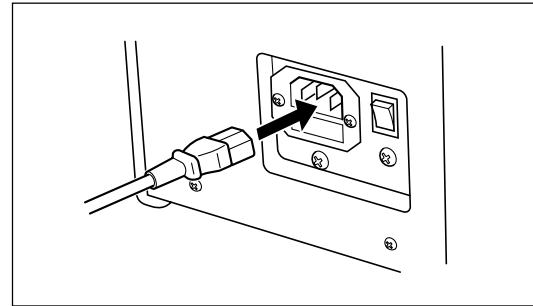

2. Place a flat-blade screwdriver on the fuse holder as shown, and pull it toward you to remove the holder.

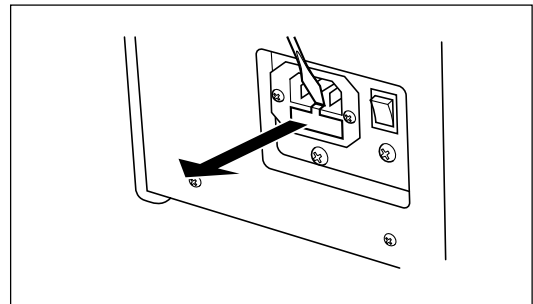

3. Replace the fuse with a new one and set the fuse holder in place.

- ◆ If the fuse blows off soon after it has been replaced, disconnect the AC power cord from the AC outlet, then contact the nearest Minolta-authorized service facility.

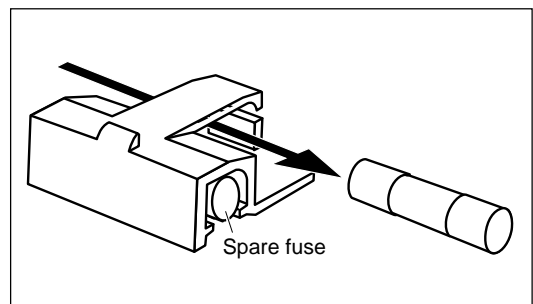
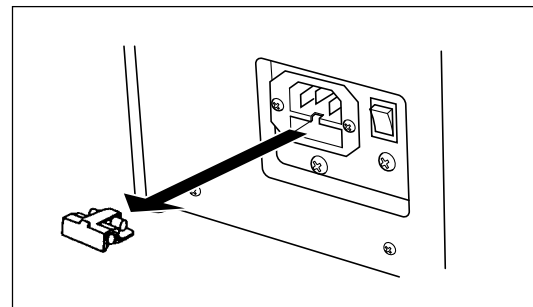

MEASURING PRINCIPLE

The VIVID 300 uses the light-stripe method to emit a horizontal stripe light through a cylindrical lens to the object. The reflected light from the object is received by the CCD, and then converted by triangulation into distance information. This process is repeated by scanning the stripe light vertically on the object surface using a galvano mirror, to obtain a 3D image data of the object.

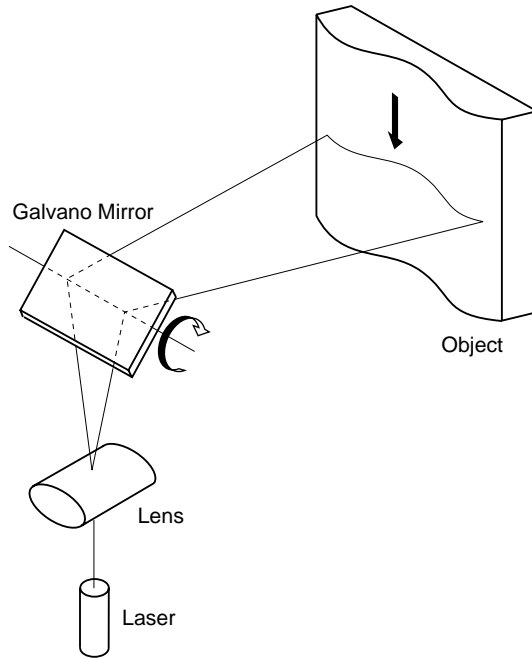

High-Speed Image Processing Circuit

The VIVID 300 uses a CCD which can be operated in 2 modes (charge output and charge drain modes), to enable high-speed acquisition of range images.

After 1-frame CCD exposure, among the signal charges transferred to the memory, only those of the reflected light from the object surface are extracted by block readout while the other signal charges are drained at once.

The stripe light is scanned on the CCD image plane at one horizontal line per frame and the CCD is driven so that the block readout start position is shifted one line per frame, to acquire a total of approximately 250 frames of the image.

(CCD driving rate: 14.3 MHz, block readout: 38 lines, data acquisition speed: 0.6 seconds)

The output signal from the CCD is then sent to the analog processing portion, where it is amplified and subjected to waveform processing. It is then converted into a digital signal (i.e., image data) and saved in the frame memory.

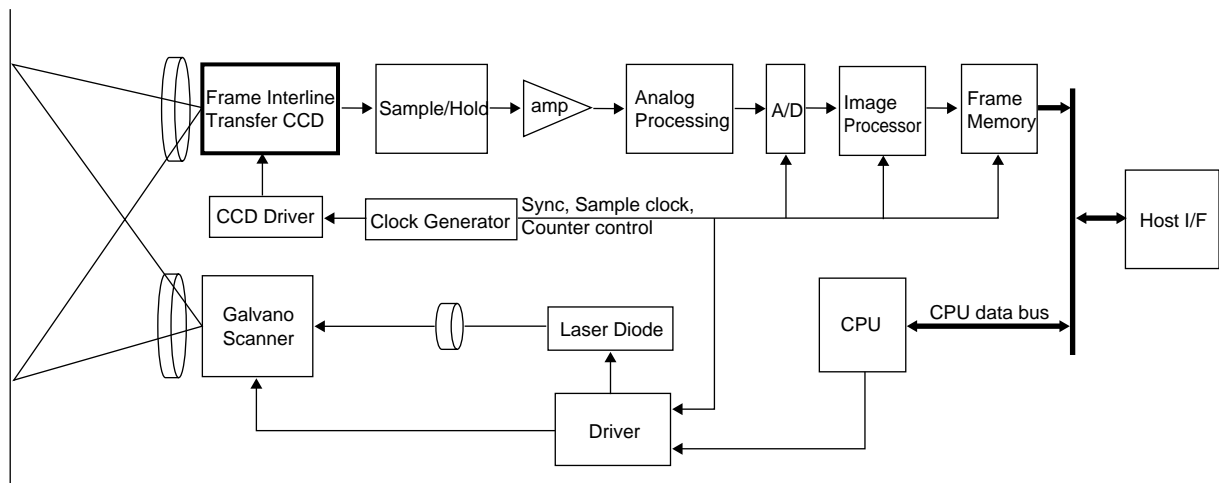

DIMENSION DIAGRAM

(Unit: mm)

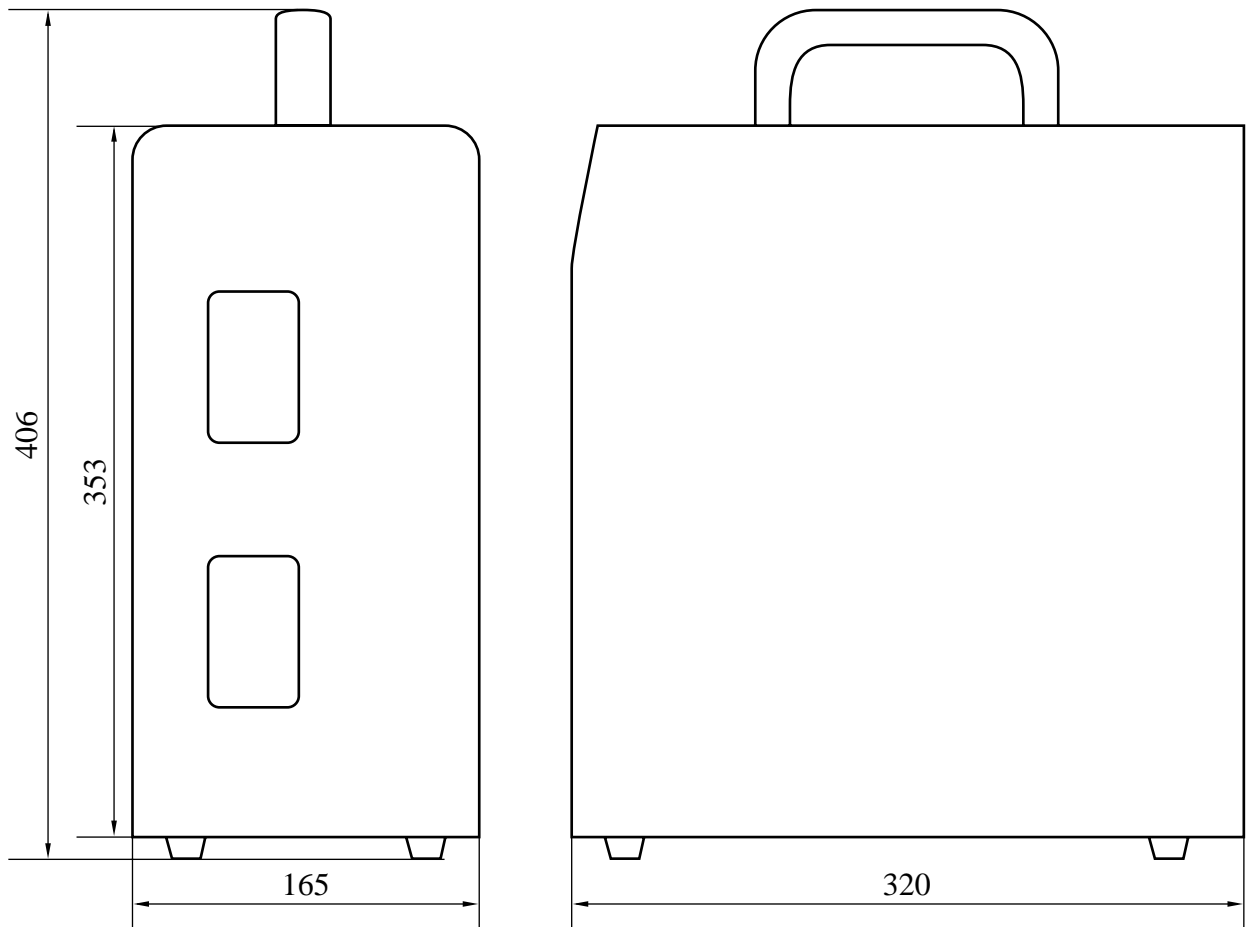

SPECIFICATIONS

Model Name	VIVID 300/VI-300
Light-Receiving Lens	f = 12 mm
Laser Power	$\lambda = 690$ nm, Max. 7 mW (Class I or equivalent, controlled and emitted by the internal control circuit and optics)
Beam Spread Angle (2σ)	Horizontal : 23.7° Vertical : 0.1°
Laser Scanning Method	Galvano mirror
Object Distance Range	0.55 to 1.2 m
Field of View (each side of field of view xy)	185 to 395 mm
Operative Distance Range ($\angle z$)	Equivalent to each side of the field of view (when image input distance is 1.2 m)
Scanning Time	0.6 sec.
Image Data Transfer Time to Host Computer	2.0 sec. or less
Ambient Lighting Condition	500 lx or less
Imaging Device	3D data : 1/2-inch frame transfer CCD (380,000 picture elements) Color data : 1/2-inch color CCD (380,000 picture elements)
Output Data Points	3D data : 200 × 200 Color data : 400 × 400
Save/Output Format	3D data : Original format (converted to 3D data by the utility software VI-S1) Color data : RGB 24-bit raster scan data
Output Interface	SCSI II, color monitor NTSC terminal
Power	100 to 240 V~ (50 to 60 Hz), 0.6 A (rated 100 V~)
Fuse	Type T2A 250V
Dimensions	165 (W) × 406 (H) × 320 (D) mm
Weight	8 kg
Operating Temperature Range	10 to 35°C (85% relative humidity or less, no condensation at 35°C)
Storage Temperature Range	-20 to 50°C (85% relative humidity or less, no condensation at 35°C)

