

NON-CONTACT 3D DIGITIZER

VIVID 910/VI-910

Instruction Manual (HARDWARE)

NOTE

The VI-910 is model name for Europe and the VIVID 910 is model name for other countries.
Please note that the VIVID 910 model name is intended only for reference with this manual.

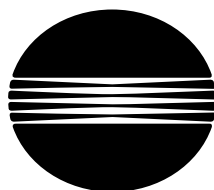

MINOLTA

Safety Symbols

The following symbols are used in this manual to prevent accidents which may occur as result of incorrect use of the instrument.



Denotes a sentence regarding safety warning or note.
Read the sentence carefully to ensure safe and correct use.



Denotes a prohibited operation.
The operation must never be performed.



Denotes an instruction.
The instruction must be strictly adhered to.



Denotes an instruction.
Disconnect the AC power cord from the AC outlet.



Denotes a prohibited operation.
The part must never be disassembled.



Denotes an instruction.
Connect the grounding terminal as instructed.

















Denotes a sentence regarding safety precaution for laser.
Read the sentence carefully to ensure safe and correct use.





Notes on this Manual

- Copying or reproduction of all or any part of the contents of this manual without MINOLTA's permission is strictly prohibited.
- The contents of this manual are subject to change without prior notice.
- Every effort has been made in the preparation of this manual to ensure the accuracy of its contents. However, should you have any questions or find any errors, please contact a Minolta-authorized service facility.
- MINOLTA will not accept any responsibility for consequences arising from the use of the instrument.
- Company names and product names which appear in this manual are their trademarks or registered trademarks.
- Contents and display examples given in this manual are subject to change.

Safety Precautions

When using this hardware, the following points must be strictly observed to ensure correct and safe use. After you have read this manual, keep it in a safe place so that it can be referred to easily whenever it is needed.

 WARNING Failure to adhere to the following points may result in death or serious injury.			
	Do not use the VIVID 910 in places where flammable or combustible gases (gasoline etc.) are present. Doing so may cause a fire.		Do not disassemble or modify the VIVID 910. Doing so may cause a fire or electric shock.
	Always use the AC power cord supplied as a standard accessory with the VIVID 910, and connect it to an AC outlet (100-240 V~, 50-60 Hz). Failure to do so may damage the VIVID 910, causing a fire or electric shock.		Do not remove the cover as doing so may cause electric shocks.
	Do not bend, twist or pull the AC power cord excessively. In addition, do not place heavy items on the AC power cord, or damage or modify it in any way. Doing so may cause damage to the AC power cord, resulting in fire or electric shock.		Take special care not to allow liquid or metal objects to enter the VIVID 910. Doing so may cause a fire or electric shock. Should liquid or metal objects enter the VIVID 910, turn the power OFF immediately, disconnect the AC power cord from the AC outlet, and contact the nearest Minolta-authorized service facility.
	If the VIVID 910 will not be used for a long time, disconnect the AC power cord from the AC outlet. Accumulated dirt or water on the prongs of the AC power cord's plug may cause a fire. If there is any dirt or water on the prongs of the AC power cord's plug, remove it.		The VIVID 910 should not be operated if dirt or dust has entered through the vent holes. Doing so may result in a fire. For periodic inspection, contact the nearest Minolta-authorized service facility.
	When disconnecting the AC power cord's plug, always hold the plug and pull it to remove it. Never pull the AC power cord itself. Doing so may damage the AC power cord, causing a fire or electric shock. In addition, do not insert or disconnect the AC power cord's plug with wet hands. Doing so may cause electric shock.		Never stare into the laser emitting window. 
	The VIVID 910 should not be operated if it is damaged, or smoke or odd smells are detected. Doing so may result in a fire. In such situations, turn the power OFF immediately, disconnect the AC power cord from the AC outlet, and contact the nearest Minolta-authorized service facility.		Do not place a lens, mirror or optical element in the passage of the laser beam. Doing so may converge the laser beam, resulting in damage to your eyes, burns or fire. To prevent the above accidents, make sure that a wall or similar which can block the laser beam is located behind the object. 

 CAUTION Falling to adhere to the following points may result in injury or damage to the instrument or other property.			
	Be sure to connect the AC power cord's plug to an AC outlet that has a grounding terminal.		Do not place the instrument on an unstable or sloping surface. Doing so may result in its dropping or overturning, causing injury. Take care not to drop the instrument when carrying it.
	Make sure that the AC outlet is located near the VIVID 910 and that the AC power cord's plug can be easily connected and disconnected.		

Laser Caution and Identification Label

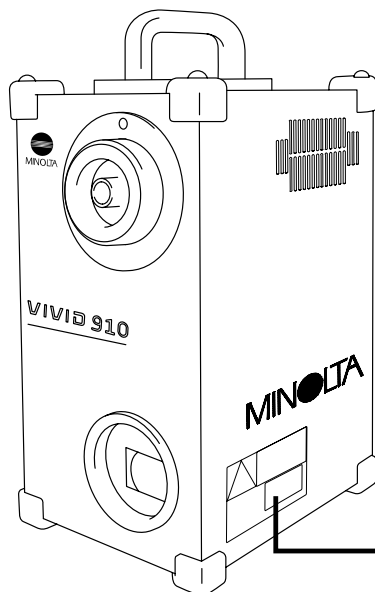

Laser Caution and Identification Label

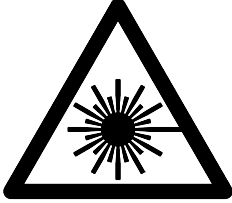

AVOID EXPOSURE
Laser radiation is emitted
from this aperture.

CAUTION
レーザー光
ビームをのぞきこまないこと
LASER RADIATION
DO NOT STARE INTO BEAM
LASER STRAHLUNG
NICHT IN DEN STRAHL SEHEN
MAX 30mW 690nm
クラス2 レーザ製品 CLASS 2 LASER PRODUCT
Complied with IEC Publication 60825-1:1993, Amendment-1:1997

CLASS 1 LASER PRODUCT

Complies with 21 CFR Chapter 1, Subchapter J.
MINOLTA CO.,LTD. 3-13,2-Chome, Azuchi-Machi, Chuo-ku, Osaka 541-8556 Japan
manufactured

Warning Label

⚠ 警告 ⚠ WARNING ⚠ WARNUNG

- 使用前には、必ず取扱説明書をよくお読みください。
Read and understand all instructions before using.
Vor Inbetriebnahme unbedingt zuerst alle Hinweise zur Bedienung und Handhabung sorgfältig studieren.
- 本機を改造あるいは分解しないでください。火災、感電、または傷害の原因になります。
Risk of electric shock, fire or injury, not modify or disassemble this instrument.
Elektroschock, Feuergefahr und Verletzung
Das Gerät nicht demontieren oder Veränderungen am Gerät vornehmen.
- コンセントが近くにあり、電源プラグの抜き差しが容易にできること
The socket-outlet shall be installed near equipment and shall be easily accessible.
Die Netzsteckdose sollte leicht erreichbar und in der Nähe des Gerätes installiert sein.

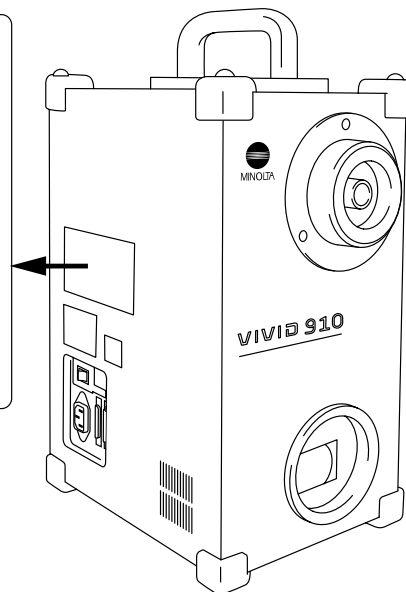

Notes On Use

- The VIVID 910 should be used within a temperature range of 10 to 40°C at a relative humidity of 65% or less.
- Do not use the VIVID 910 in direct sunlight or near sources of heat such as stoves. Doing so will cause the temperature of the VIVID 910 to rise considerably higher than room temperature and may result in malfunctions. Use the VIVID 910 in a well ventilated area and make sure that the ventilation holes of the VIVID 910 are not blocked.
- Do not use the VIVID 910 in extremely dusty or humid areas. Doing so may result in malfunctions.
- Do not subject the VIVID 910 to strong vibration or shocks. Doing so may result in malfunctions.
- Do not disconnect cords and cables with the POWER switch of the VIVID 910 set to ON “I”. Doing so may result in malfunctions.
- The VIVID 910 has been tested and found to comply with the limits for a Class A digital device, pursuant to Part 15 of the FCC Rules. These limits are designed to provide reasonable protection against harmful interference when the equipment is operated in a commercial environment. This equipment generates, uses, and can radiate radio frequency energy and, if not installed and used in accordance with the instruction manual, may cause harmful interference to radio communications. Operation of this equipment in a residential area is likely to cause harmful interference in which case the user will be required to correct the interference at his own expense.
- The VIVID 910 falls into the category of a Class A information technology device based on the VCCI standards. Using it in a domestic environment may cause radio interference. In such cases, the user may be requested to take appropriate measures.
- The VIVID 910 is a class II instrument specified in IEC Publication 825. Use it according to the instructions given in this manual.

Care On Storage

- The VIVID 910 should be stored in areas with temperatures of between –10 and +50°C. Do not store it in areas subject to high temperature or high humidity or where sudden changes in temperature or condensation are likely to occur. We recommend storing the VIVID 910 at a relatively constant temperature with a desiccant (silica gel etc.).
- Do not leave the VIVID 910 inside a closed car or in the trunk of a car. Under direct sunlight, the increase in temperature can be extreme and may result in malfunctions.
- The VIVID 910 should not be stored in areas where there is an excessive amount of dust, cigarette smoke or chemical gas. Failure to adhere to this may result in performance degradation or break-down.
- Lenses that are not in use should be capped and kept in the lens case.

Notes On Cleaning

- If the VIVID 910 needs cleaning, wipe with a soft dry cloth. Never use solvents such as thinner or benzene.
- If the lens or laser emitting window is soiled with sand or dust, blow off the dirt using a blower, and wipe them gently with a piece of cleaning paper dampened with cleaning agent.
- In cases of malfunction, do not disassemble the VIVID 910 or attempt to repair it yourself. Contact the nearest Minolta-authorized service facility.

Notes On Maintenance

To maintain the accuracy of the high-precision Galvano mirror, that plays the most important role in measurement accuracy, a drying agent is used inside the VIVID 910. Normally, the dehumidification effect of the drying agent lasts more than one year. However, its life varies with the operating and storage environment.

To maintain the designed performance of the VIVID 910, you are recommended to replace the drying agent once a year. Contact the nearest Minolta-authorized service facility.

Contents

Safety Precautions.....	1
Laser Caution and Identification Label.....	2
Warning Label.....	2
Notes On Use.....	3
Care On Storage.....	3
Notes On Cleaning.....	3
Notes On Maintenance.....	3

Chapter 1 Before Using the Instrument

Package Contents (Standard Accessories)	6
Optional Accessories	7
System Configuration	8
Names and Functions of Parts	9
Main Body.....	9
Operation Panel.....	10

Chapter 2 Preparation

Connecting the AC Power Cord	12
Turning Power ON/OFF	13
Setting the Date and Time	15
Connecting the VIVID 910 to a Computer	17
Setting the SCSI ID No.....	18
Setting the Terminator	19
Memory Card	21
Notes When Using the Instrument with Tripod	22
Mounting to the Tripod.....	22

Chapter 3 Operation

Replacing the Lens	26
Relationship between Measurement Distance and Object.....	26
Replacing Procedure	27
Scanning the Object	30
Displaying the Scan Results.....	32
High Quality Mode	33
Setting Focus Lock.....	35
Setting Manual Focus.....	36
Adjusting the Laser Power and CCD Gain Manually.....	37
Setting the Scan Reference Distance	39
Setting Auto Read	41
Setting the Color Level	42
Adjusting the White Balance	43
Data File Management	45
Selecting the File Name Input Method	45
Saving a File.....	47
Loading a File	48
Changing a File Name.....	49
Deleting a File.....	50
Displaying the Status Information	51

Chapter 4 Appendix

Error Messages	54
Explanation of Measuring Principle	56
Measuring Principle	56
High-Speed Image Processing Circuit	57
Time center of gravity and Space center of gravity	57
Dimension Diagram	58
Specifications	59



Chapter 1

Before Using the Instrument

Package Contents (Standard Accessories)

Check that the following standard accessories are present.

VIVID 910 Main Body

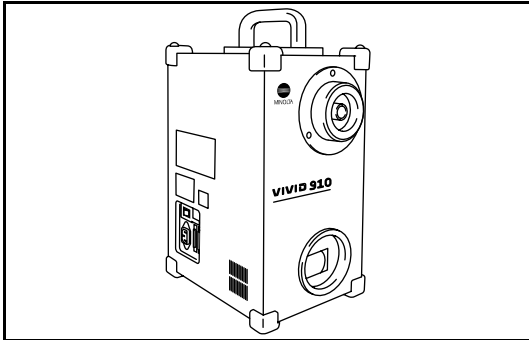

Polygon Editing Tool

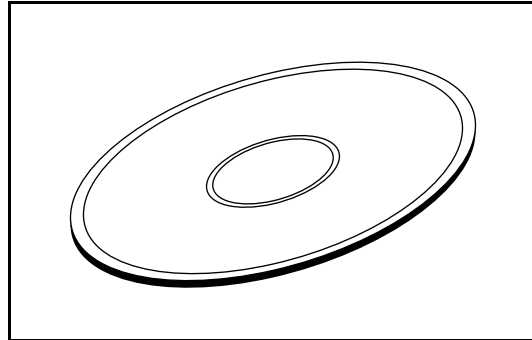

White Balance Cap VI-A10

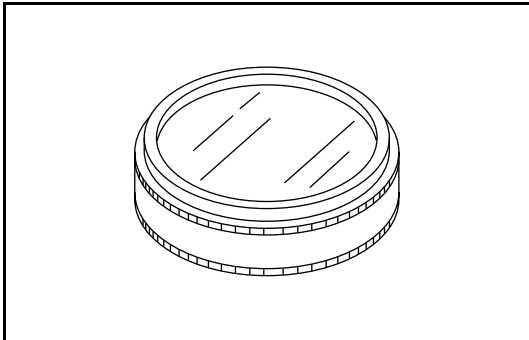

AC Power Cord

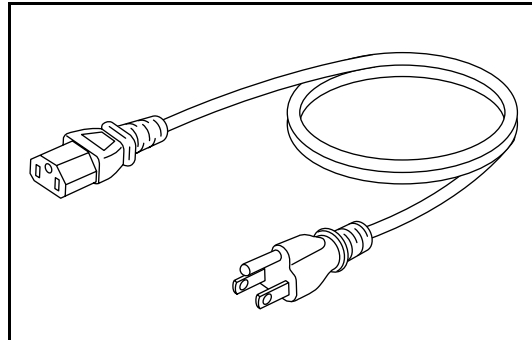

Lens (3 types, with Lens Case)

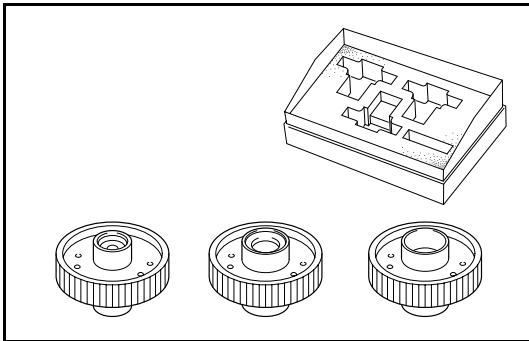

Laser Barrier

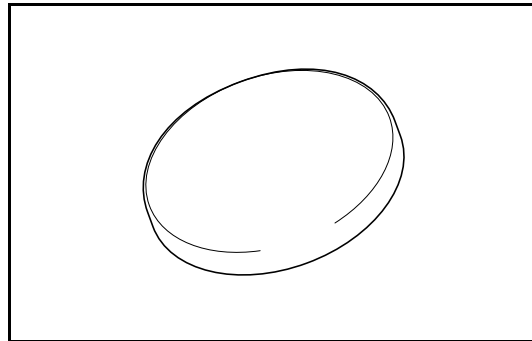

SCSI Cable VI-A20

Half-pitch, D-sub, 50-pin male plug – 50-pin male plug

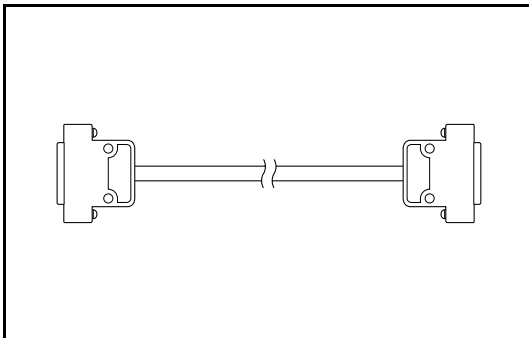

SCSI Conversion Connector V1-A21

50-pin female plug – 50-pin male plug

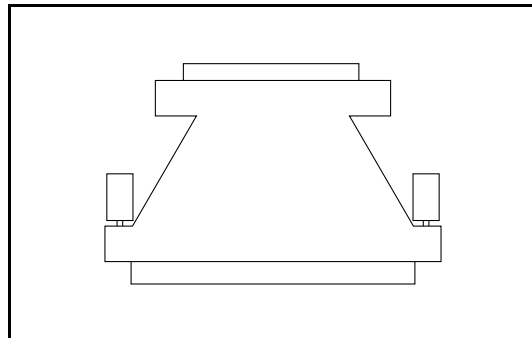

Optional Accessories

When you need to purchase the following optional items, contact a Minolta-authorized service facility.

Rotary Stage Set

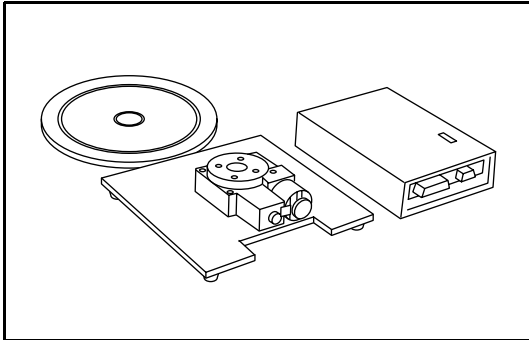

Memory Card

(Compact Flash Card VI-A12 + PC Card Adapter VI-A13)

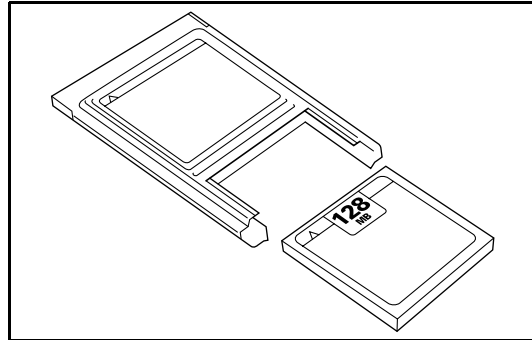

Tripod/Panhead

Information about the recommended tripod/panhead, please contact the nearest Minolta Authorized Service Facility.

Bench Top Frame Set

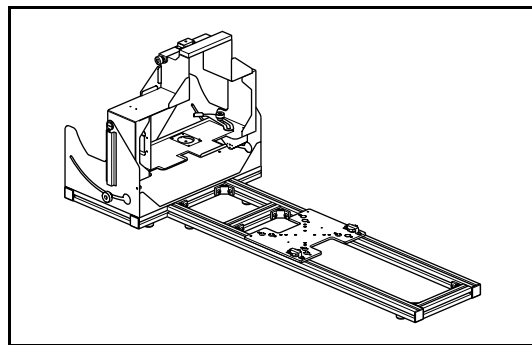

System Configuration

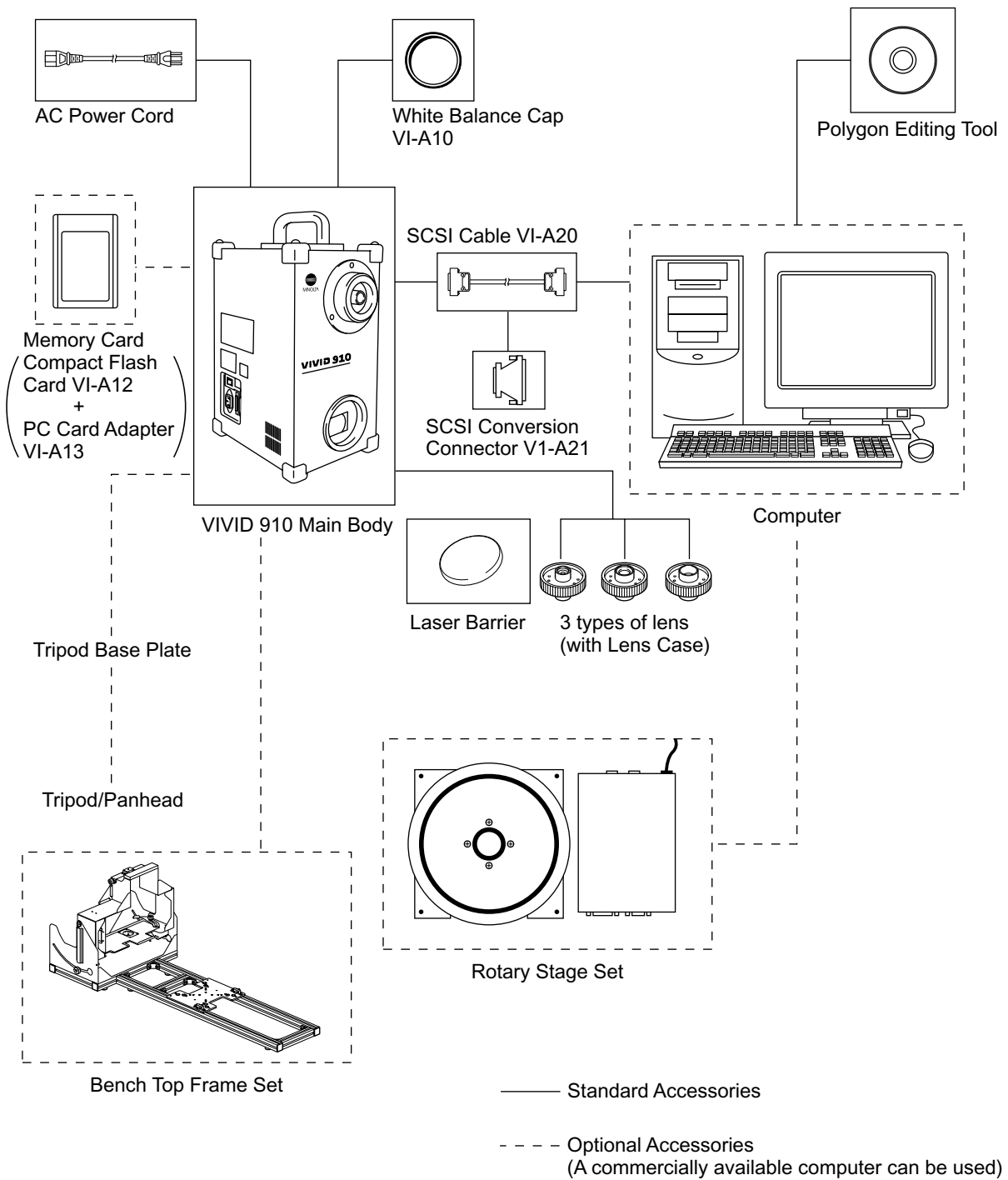

Names and Functions of Parts

Main Body

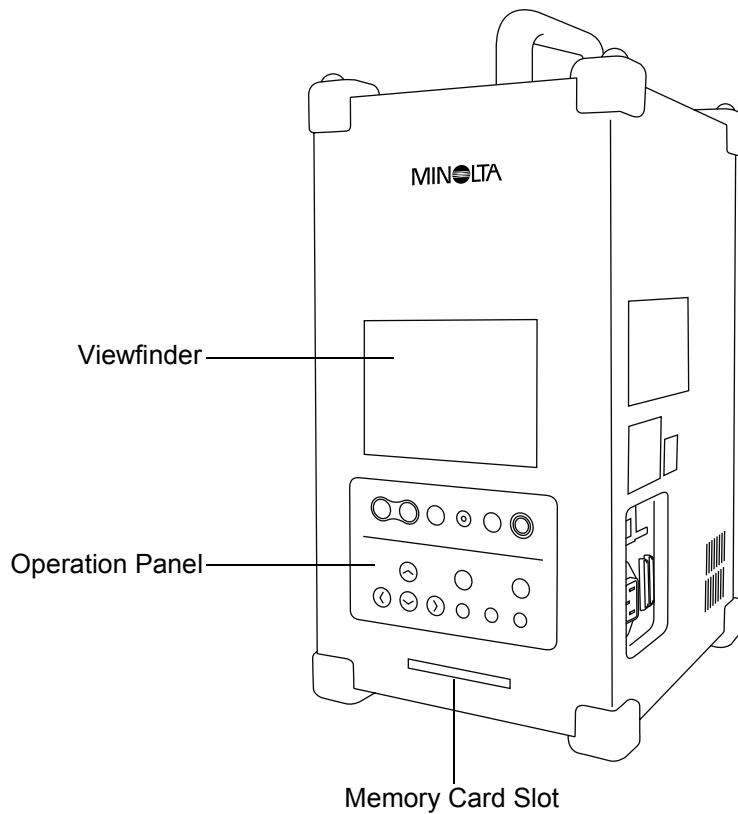
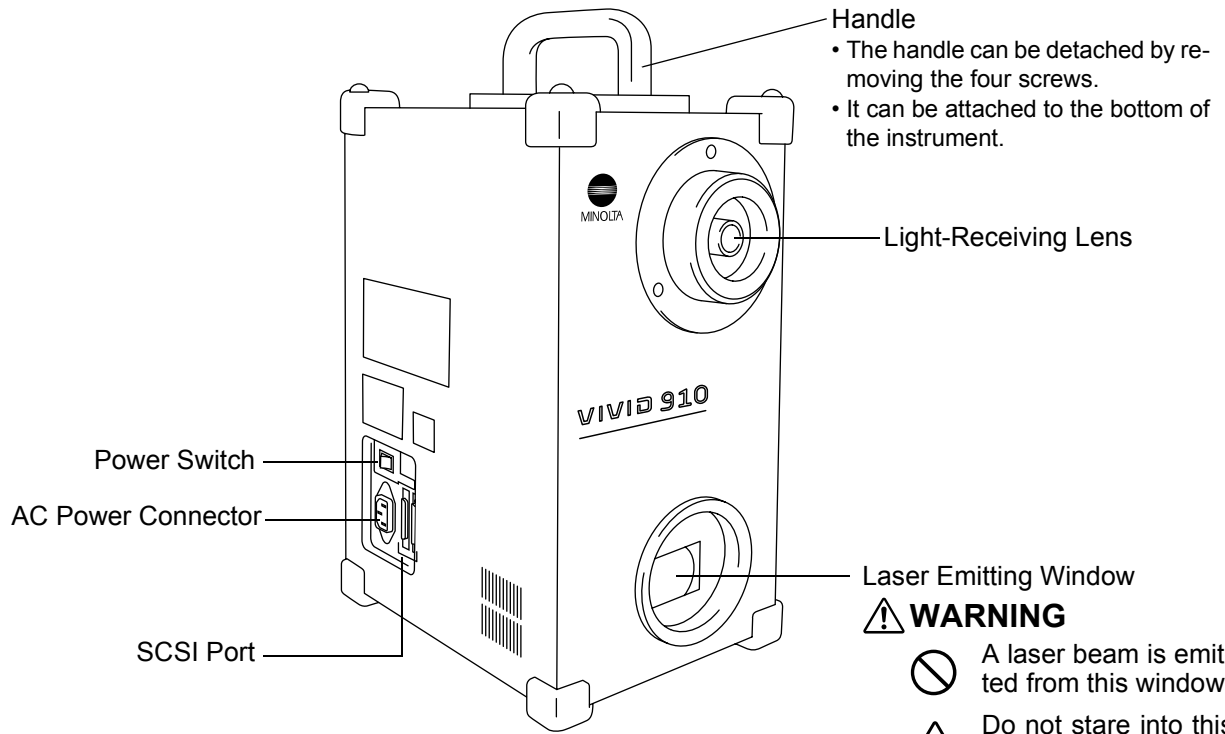

Operation Panel

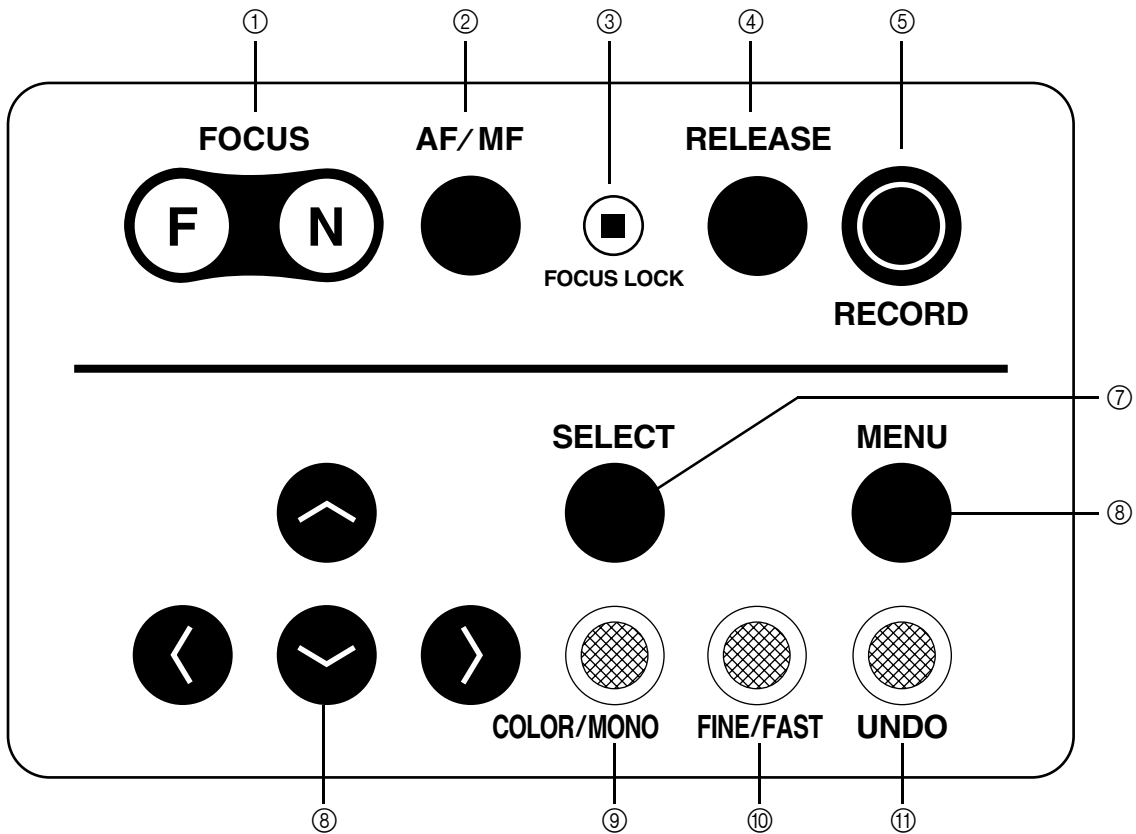

- ① **FOCUS key** Focuses the image manually. “F” indicates “far” and “N” indicates “near”.
- ② **AF/MF key** Switches from auto (AF) to manual focus (MF) or vice versa.
- ③ **FOCUS LOCK key** Fixes the focus to scan the object.
- ④ **RELEASE key** Performs a scan.
- ⑤ **RECORD key** Records (saves) the scanned image to the Memory card.
- ⑥ **SELECT key** Confirms selection of the items displayed on the viewfinder.
- ⑦ **MENU key** Displays the MENU view on the viewfinder.
- ⑧ **↔** Moves from one item to another displayed on the viewfinder.
- ⑨ **COLOR/MONO key** Switches the image on the viewfinder from color to monochrome or vice versa.
- ⑩ **FINE/FAST key** Switches scan mode from FINE to FAST or vice versa.
- ⑪ **UNDO key** Mainly used to cancel operations of keys.

Memo

MENU is a key provided to display the MENU view from which basic operations of this instrument can be performed. If you are not sure during operation which view is which, press **MENU** to return to the MENU view.
 (The MENU view may not be displayed even if **MENU** is pressed depending on the view currently displayed.)

Chapter 2

Preparation

Connecting the AC Power Cord

To ensure correct connection of the AC power cord, read the points given in WARNING and CAUTION carefully.

WARNING

- ❗ Always use the AC power cord supplied as a standard accessory with the VIVID 910, and connect it to an AC outlet (100-240 V ~, 50/60 Hz). Failure to do so may damage the VIVID 910, causing a fire or electric shock.
- ⊘ Do not bend, twist or pull the AC power cord excessively. Do not place heavy items on it, scratch or modify it. Doing so may damage it, resulting in fire or electric shock.
- 🌍 If you are not going to use the VIVID 910 for a long time, disconnect the AC power cord from the AC outlet. If dirt or water accumulates on the prongs of the AC power cord's plug, it may cause a fire. If there is any dirt or water on the prongs, it must be removed.
- ❗ When disconnecting the AC power cord's plug, always hold the plug and pull it to remove it. Never pull the AC power cord itself as it may be damaged, resulting in fire or electric shock. Also do not insert or disconnect the AC power cord's plug with wet hands. Doing so may cause electric shock.

CAUTION

- ⚠ Be sure to connect the AC power cord's plug to an AC outlet that has a grounding terminal.
- ❗ Make sure that the AC outlet is located near the VIVID 910 and that the VIVID 910's AC power cord's plug can be easily connected and disconnected.

[Connecting Procedure]

- 1 Set the power switch of the VIVID 910 to OFF ("O").

Note

If the AC power cord is connected to an AC outlet with the power switch set to ON ("|"), damage to the VIVID 910 or computer may result.

Before connecting the AC power cord, always make sure that the power switch is set to OFF.

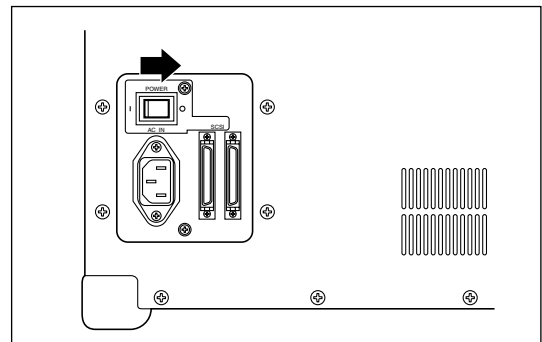

- 2 Plug the AC power cord to the AC power connector on the VIVID 910.

- 3 Plug the other end of the AC power cord to an AC outlet.

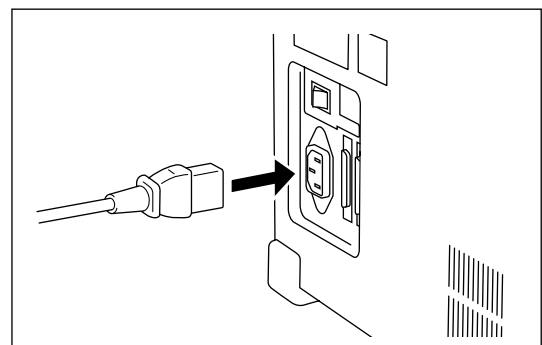

Turning Power ON/OFF

[Turning Power ON]

- 1 Set the power switch to ON (“|”).**

Power will be supplied to the VIVID 910 and initial setup is performed. After approximately 10 seconds, “PLEASE OPEN LASER BARRIER AND PRESS ANY KEY” will be displayed on the viewfinder.

Note

When turning power ON again after it has been turned OFF, wait at least 5 seconds before doing so. Failure to observe this may result in malfunction or breakdown of the VIVID 910.

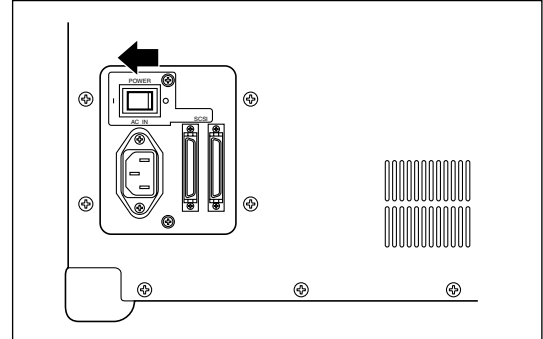

- 2 Remove the laser barrier.**

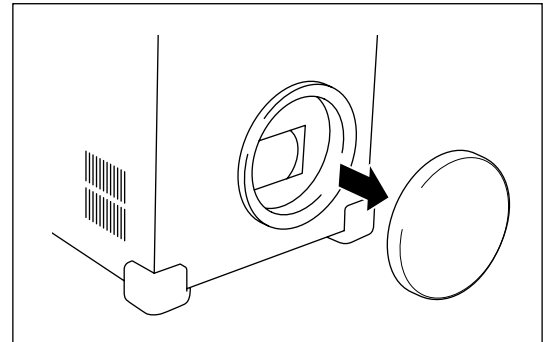

- 3 Press any key.**

The MENU view will appear, indicating that the VIVID 910 is now ready for operation.

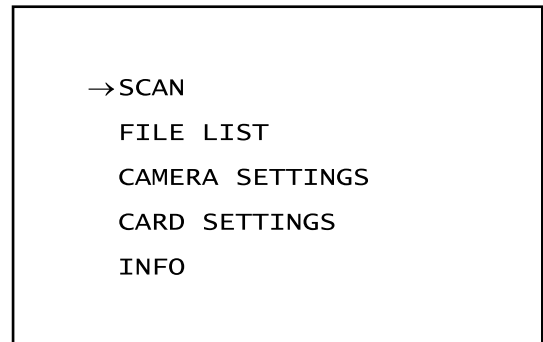

[Turning Power OFF]

- 1 Set the power switch to OFF (“○”).**
Power will be turned OFF.

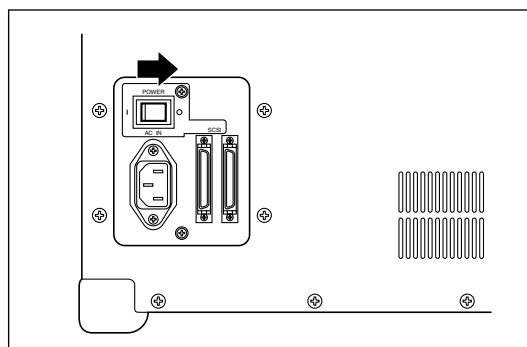

- 2 Attach the laser barrier.**

Note

To ensure safety, the laser barrier must be kept attached when the VIVID 910 is not in use.

Setting the Date and Time

Once the date and time are set, the date and time on which scan was performed will also be saved when image data is saved.







[Memo]

When the VIVID 910 is used for the first time after purchase or if it has not been used for some time, the date/time data might have been lost. If so, it must be set again.

[Note]

- If the date/time data has been lost, "CLOCK ERROR" will appear after power is turned ON. In this case, press any key and proceed to step 4 to set the date and time.
- The backup battery for the date/time data is charged while the power to the instrument is ON.

[Setting Procedure]

- 1 Press .**
The MENU view will appear.
- 2 Press  to locate the arrow cursor to "CAMERA SETTINGS".**
- 3 Press .**
The CAMERA SETTINGS view will appear.
- 4 Press  to locate the arrow cursor to "CLOCK".**
- 5 Press .**
The currently set month will turn to pink.
- 6 Press  to select the date/time item (month, date, year, hour, minute, second) to be set (or changed).**
The item currently displayed in pink can be set (or changed).

SCAN
FILE LIST
→CAMERA SETTINGS
CARD SETTINGS
INFO

→CLOCK	FEB.04.2000 16:21:58
W/B	DEFAULT
SCSI ID	5
TERMINATE	ENABLE
AUTO READ	ON
COLOR	AUTO
HIGH QUALITY MODE	OFF

CLOCK	FEB.04.2000 16:21:58
W/B	DEFAULT
SCSI ID	5
TERMINATE	ENABLE
AUTO READ	ON
COLOR	AUTO
HIGH QUALITY MODE	OFF

7 Press  .

<Settings>

- **Month:** JAN to DEC
- **Date:** 01 to 31 (varies depending on the month)
- **Year:** 2000 to 2079
- **Hour:** 00 to 23
- **Minute:** 00 to 59
- **Second:** 00 to 59

 **Memo**

Months are indicated as follows:

January	February	March	April	May	June	July	August	September	October	November	December
JAN	FEB	MAR	APR	MAY	JUN	JUL	AUG	SEP	OCT	NOV	DEC

8 Repeat steps 6 and 7 until all the desired date/time items are set (or changed).

 **Memo**

To cancel date/time setting and restore the previous date/time setting, press .

9 Press  ^{SELECT}.

Setting is now complete.

Connecting the VIVID 910 to a Computer

To operate the VIVID 910 from a computer using the Polygon Editing Tool, the VIVID 910 must be connected to the computer with a standard SCSI cable.

⚠ WARNING

❗ The computer must be operated correctly and safely according to its instruction manual.

Memo

The standard SCSI cable has a 50-pin male plug (half-pitch, D-Sub) on both its ends.

Ref. For a description of the standard accessories, refer to page 6.

[Connecting Procedure]

- 1 Set the power switch of both VIVID 910 and computer to OFF (“○”).**

Note

If the AC power cord is connected to an AC outlet with the power switch set to ON (“I”), damage to the VIVID 910 or computer may result.

Before connecting them, always make sure that power is turned OFF.

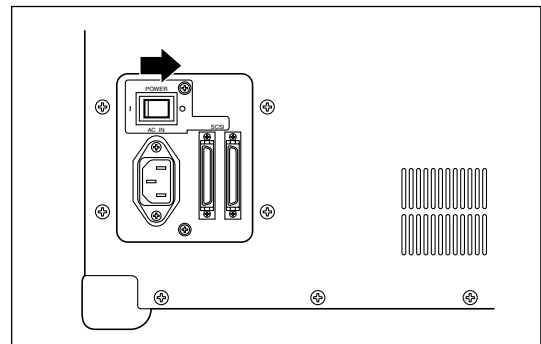

- 2 Plug the SCSI cable to a SCSI port of the VIVID 910.**

- 3 Plug the other end of the SCSI cable to the SCSI connector of the computer.**

Connecting procedure is now complete

Note

Before turning ON the power to the computer, always turn ON the power to the VIVID 910 and wait until it is ready for operation (see page 13).

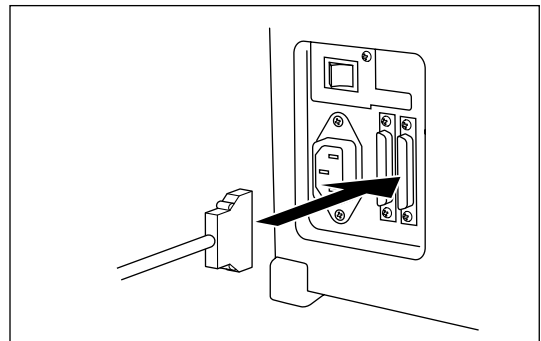

Setting the SCSI ID No.

In order for the computer to recognize that the VIVID 910 is connected to the computer via the SCSI interface, a SCSI ID No. (0 to 6) must be set for the VIVID 910.







Memo

SCSI ID No. 5 has been set as the default setting before shipment.

Note

If other devices are connected to the computer via the SCSI interface, make sure that the SCSI ID No. of the VIVID 910 differs from those set for the devices.

[Setting Procedure]

- 1 Press . The MENU view will appear.
- 2 Press  to locate the arrow cursor to "CAMERA SETTINGS".
- 3 Press . The CAMERA SETTINGS view will appear.
- 4 Press  to locate the arrow cursor to "SCSI ID".
- 5 Press . The currently selected SCSI ID No. will turn to pink.
- 6 Press  to select the desired SCSI ID No.
 <Settings>
 • 0 to 6: SCSI ID No.
- 7 Press . Setting is now complete.

SCAN
FILE LIST
→CAMERA SETTINGS
CARD SETTINGS
INFO

CLOCK	FEB.04.2000 16:21:58
W/B	DEFAULT
→SCSI ID	5
TERMINATE	ENABLE
AUTO READ	ON
COLOR	AUTO
HIGH QUALITY MODE	OFF

CLOCK	FEB.04.2000 16:21:58
W/B	DEFAULT
SCSI ID	5
TERMINATE	ENABLE
AUTO READ	ON
COLOR	AUTO
HIGH QUALITY MODE	OFF

Setting the Terminator

The VIVID 910 has a built-in SCSI terminator. The terminator is required if the VIVID 910 is the last device of those connected in series to the SCSI interface (i.e., if only one of the SCSI ports on the VIVID 910 is used).

- ❶ If the terminator is not set correctly, the VIVID 910 or devices connected to the SCSI interface may malfunction.









Memo

“ENABLED” has been selected as the default setting before shipment.

INote

“DISABLE” must be selected if the VIVID 910 is connected via the SCSI interface but is not the last device of those connected in series, and “ENABLE” must be selected if it is not connected via the SCSI interface. (An error message will appear if “DISABLE” is selected even though the VIVID 910 is not connected via the SCSI interface.)

[Setting Procedure]

- 1 Press .
The MENU view will appear.
- 2 Press   to locate the arrow cursor to “CAMERA SETTINGS”.
- 3 Press .
The CAMERA SETTINGS view will appear.
- 4 Press   to locate the arrow cursor to “TERMINATE”.
- 5 Press .
The currently selected option (ENABLED or DISABLED) will turn to pink.
- 6 Press   to select “ENABLED” or “DISABLED”.

<Settings>

- **ENABLED:** Select this option if the terminator is to be used.
- **DISABLED:** Select this option if the terminator is not to be used.

SCAN
FILE LIST
→CAMERA SETTINGS
CARD SETTINGS
INFO

CLOCK	FEB.04.2000 16:22:28
W/B	DEFAULT
SCSI ID	5
→TERMINATE	ENABLE
AUTO READ	ON
COLOR	AUTO
HIGH QUALITY MODE	OFF

CLOCK	FEB.04.2000 16:22:28
W/B	DEFAULT
SCSI ID	5
TERMINATE	ENABLE
AUTO READ	ON
COLOR	AUTO
HIGH QUALITY MODE	OFF

- 7** Press .
Setting is now complete.

Memory Card

By using the PC card adapter VI-A13, image data can be saved to the compact flash card VI-A12.

Note

- The memory card slot on the VIVID 910 can accommodate a PC card (TYPE II, PC Card Standard Release 2.1). To save image data, insert the optional compact flash card VI-A12 into the PC card adapter VI-A13, then insert the adapter into the slot.
- Make sure that the compact flash card and PC card adapter are positioned in the correct direction when they are inserted. Failure to observe this may cause breakdown of the cards.
- This memory card cannot be used with the VIVID 700 (VI-700). Doing so will delete the data saved in the memory card.
- This memory card is designed for use with the VIVID 900/910 only, so it must not be used with any other VIVID models. Data saved by the VIVID 900 can also be retrieved by this instrument.

Ref.

For a description of data file management (saving, loading, selecting etc.), refer to pages 45 to 50.

[Inserting/Ejecting the PC Card Adapter]

- 1 When inserting the compact flash card into the PC card adapter, make sure that it is correctly oriented.

Note

The PC card adapter VI-A13 with the compact flash card VI-A12 inserted is called the memory card in this manual.

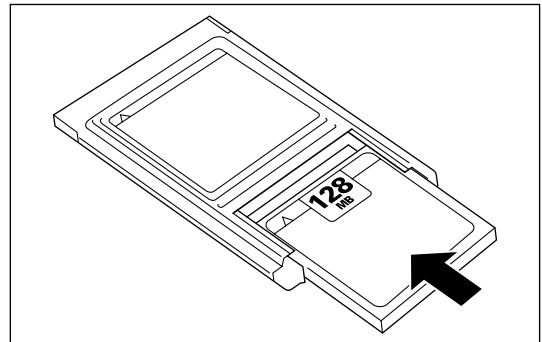

[Inserting]

- 1 Position the memory card so that the “▼” mark on the memory card is aligned with “▲” on the VIVID 910, then insert the memory card into the slot.

Note

- Make sure that the memory card is inserted into the slot until the eject button pops out.
- The memory card will be accessed immediately after it has been inserted, so do not remove it for at least five seconds.

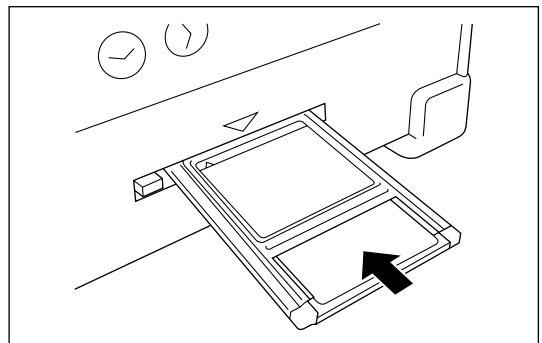

[Ejecting]

- 1 Press the eject button.

Note

- Never attempt to eject the memory card while scan is performed after **RELEASE** is pressed. Doing so may cancel scan or hinder acquirement of correct data.
- Never attempt to eject the memory card during data loading or saving. Doing so may damage the VIVID 910 or memory card.

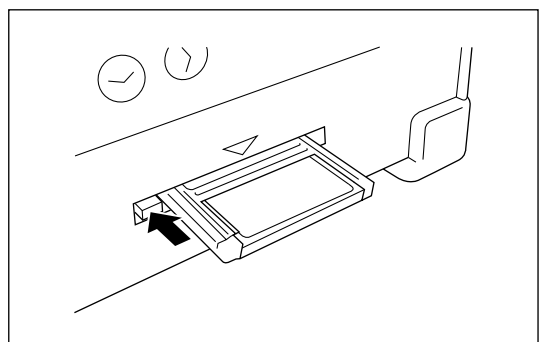

Notes When Using the Instrument with Tripod

When using the instrument with the tripod, first attach the tripod base plate to the instrument, and then attach the instrument to the panhead/tripod. To improve scanning accuracy, it is recommended that scanning be performed via the personal computer connected to the instrument, instead of pressing the [RELEASE] key.

CAUTION

- Make sure that the tripod base plate, panhead and tripod are secured to the instrument and each fastener on the tripod is firmly tightened. Failure to observe this point may result in the tripod overturning or the instrument dropping.
- When placing the tripod on a floor, examine the floor conditions and flatness to make sure that the tripod is stably placed.
- After measurement is completed, the instrument must be removed from the tripod before storing them. If the instrument is stored with the tripod attached, the tripod may overturn or the instrument may drop, resulting in accidents.

Mounting to the Tripod

1. Mounting the Tripod base plate to the Instrument

Before mounting the instrument to the tripod, mount the tripod base plate to the instrument as explained below.

[Memo]

- Five screw holes for the tripod base plate are provided on both the top and base of the instrument.
- The instrument can be attached upside down to the tripod. In this case, remove the handle from the top of the instrument, mount the tripod base plate on the top of the instrument, then mount the handle on the base of the instrument.

[Mounting the Tripod base plate]

- 1** Make sure that the power to the instrument is OFF, and remove the power cord.
- 2** Turn the instrument slowly so that its side faces down, and place it on a flat table.
- 3** Place the tripod base plate on the base (or top) of the instrument, and secure it with the five screws (supplied with the tripod base plate).
* Make sure that screw washers are fitted into the dents on the base of the instrument.
- 4** If you have removed the handle from the top of the instrument, attach it to the base of the instrument.

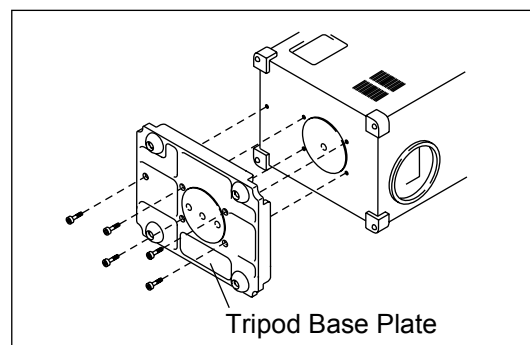

2. Mounting the Instrument to the Panhead

After you have attached the tripod base plate to the instrument, they need to be mounted to the recommended panhead as explained below.

First, remove the accessory plate from the panhead, attach it to the instrument, then attach both to the panhead.

Memo

Three screw holes are provided on the back of the tripod base plate (the side with rubber feet), to allow mounting the tripod base plate to the panhead.

[Attaching the Accessory Plate]

- 1 Remove the accessory plate from the panhead.
- 2 Place the top of the accessory plate on the tripod base plate (attached to the instrument), and secure them with two screws (U3/8, supplied with the accessory plate).

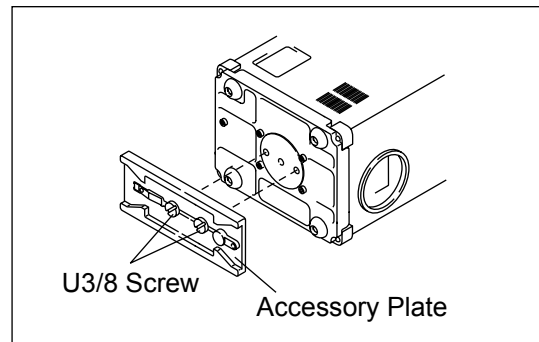

[Attaching to the Panhead]

- 1 Make sure that the tripod/panhead is secured in place.
- 2 Remove the rubber feet on the base plate with the use of a hexagonal wrench.

Memo

Remove the two rubber feet located at the rear.

Note

- *If the instrument is to be removed from the tripod/panhead and located on the base plate, attach the rubber feet.*
- *Store the rubber feet in a safe place after removal.*

- 3 Slide the accessory plate (attached to the tripod base plate on the instrument) into the panhead.
- 4 Tighten the slide fixing knob to firmly secure the accessory plate to the panhead.

Memo

Refer to the tripod/panhead instruction manual for details on using the accessory plate locking knob.

Chapter 3

Operation



Replacing the Lens

Before starting acquisition of images, the lens may need to be replaced according to the size and distance to the object.

Relationship between Measurement Distance and Object

With the VIVID 910, three types of lens are available: wide-angle lens, middle-angle lens and telescopic lens. A lens suitable for the size of the object and distance must be used.

Memo

The closer the object to the VIVID 910, the higher the measurement accuracy is. On the other hand, influences of shades produced due to roughness on the surface of the object can be reduced if the object is positioned far from the VIVID 910.

Select the most suitable lens by referring to the table given below.

WIDE Lens

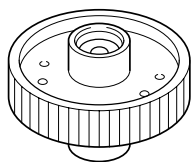

Measurement Distance		600	800	1000	1200	2000
Object Size	Horizontal	367.0	486.6	606.2	725.8	1204.2
	Vertical	275.2	364.9	454.6	544.4	903.2

Unit (mm)

MIDDLE Lens

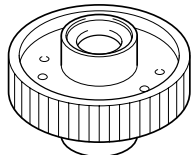

Measurement Distance		600	800	1000	1200	2500
Object Size	Horizontal	204.7	270.6	336.5	402.4	830.6
	Vertical	153.6	203.0	252.4	301.8	622.9

Unit (mm)

TELE Lens

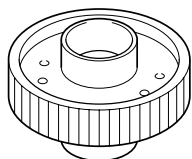

Measurement Distance		600	800	1000	1200	2500
Object Size	Horizontal	113.9	151.0	188.0	225.1	465.9
	Vertical	85.4	113.2	141.0	168.8	349.4

Unit (mm)

Replacing Procedure

The currently installed lens can be verified by the status information.
To replace the lens with another one, follow the procedure given below.

[Note]

- *Only the lenses supplied as standard accessories with the VIVID 910 can be used. (They are not compatible with other VIVID models since they have been calibrated with the VIVID 910 only.)*
- *Since the VIVID 910 is a precision instrument, do not leave it without lens when replacing the lens. Replace the lens as soon as possible.*
- *If you replace the lens before saving the image data, the image data will be lost. Before replacing the lens, all the necessary operations (e.g. saving data) must be completed.*
- *Do not touch the lens surface with fingers.*
- *If dust or dirt has collected on the lens surface, remove it using a camera air blower etc.*
- *Dust or dirt on the lens mount surface may produce incorrect measurement data. In this case, wipe the lens mount surface with a clean, dry cloth and then blow it with a camera air blower etc.*
- *Dust and dirt collected on the lens mount surface on the body side must also be removed with a camera air blower etc.*

[Ref.] For display of the status information, refer to page 51.

[Replacing Procedure]

1 Remove the lens hood.

[Memo]

The lens hood can be fixed with its bayonet mount.

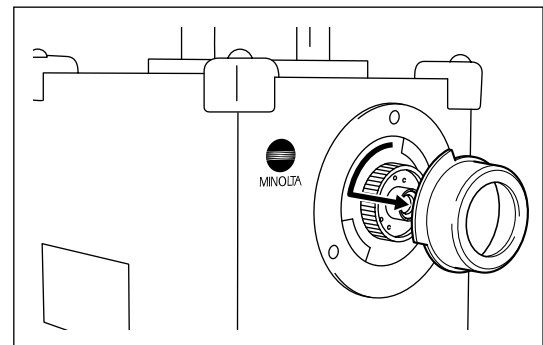

2 Turn the lens fixing ring counter-clockwise to loose it completely.

[Memo]

The lens fixing ring can be fixed with its screw mount.

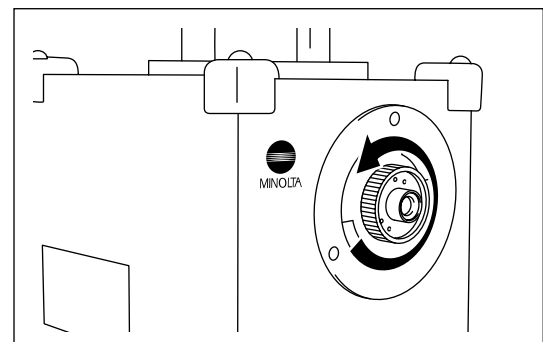

3 Hold the external edge of the fixing ring and pull it out.

[Memo]

Hold the ring with your finger located near the red mark on the lens. This will facilitate pulling the lens.

[Note]

Attach the lens cap to the removed lens, place it in the lens case and keep it in a safe place.

The following information will appear in the viewfinder as shown on the right. Check the serial number of each lens displayed.

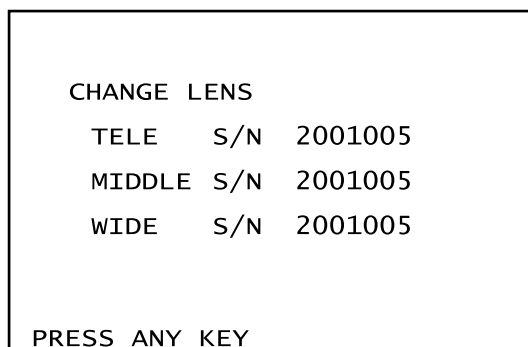
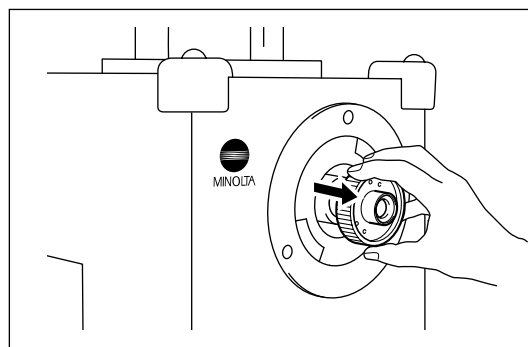

4 Attach the desired lens.

- Remove the lens cap.
- Align the red mark on the lens with the one on the lens mount socket, and insert the lens until a click is heard.

[Memo]

- The position of the red mark on the lens varies with the focus point.
- Hold the ring with your finger located near the red mark on the lens. This will facilitate inserting the lens.

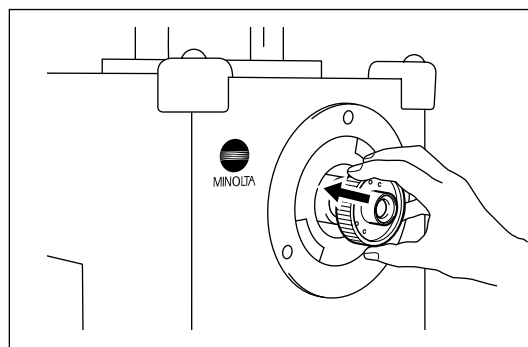

5 Turn the lens fixing ring clockwise to secure the lens.

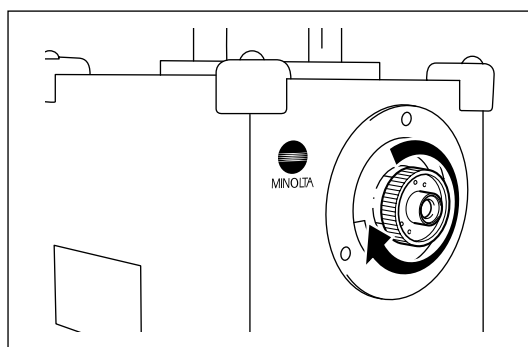

6 Attach the lens hood.

Make sure that the notch is aligned with that on the lens, and turn the hood.

[Memo]

The hood must be turned until it contacts the bayonet mount socket.

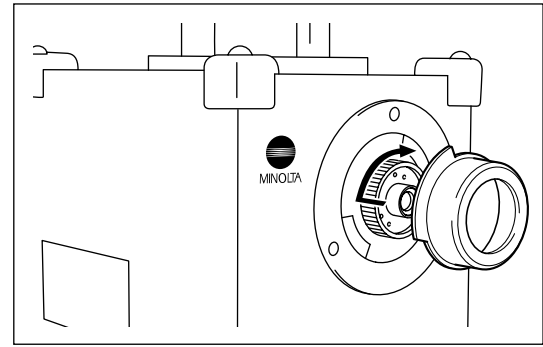
**7 Press any key.**

After approximately 10 seconds, “PLEASE OPEN LASER BARRIER AND PRESS ANY KEY” will be displayed on the viewfinder.

8 Press any key.

The MENU view will appear.

Scanning the Object



⚠ WARNING

- ⚠⊘ Never stare into the laser emitting window.
- ⚠⊘ Do not place a lens, mirror or optical element in the passage of the laser beam. Doing so may converge the laser beam, resulting in damage to your eyes, burns or fire. To prevent the above accidents, make sure that a wall or similar surface that does not reflect light is located behind the object.

Memo

For precise scan results, we recommend that you use a stable, flicker-free light source (such as a high-frequency fluorescent lamp).

[Operating Procedure]

- 1 Press .**
The MENU view will appear.
- 2 Press   to locate the arrow cursor to "SCAN".**

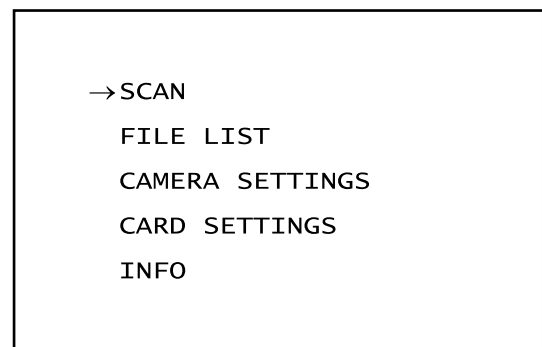

- 3 Press .**
The color image currently captured by the VIVID 910 will appear on the viewfinder.

Memo

Auto-focus will be performed automatically, and "FOCUSING" will appear. When the object is focused, "IN FOCUS" will appear.

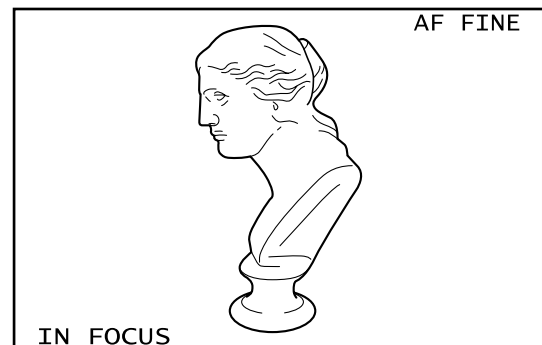



- 4 To display the object in the center of the viewfinder, change the position of the object or move the instrument back and forth to change the view angle.**

Note

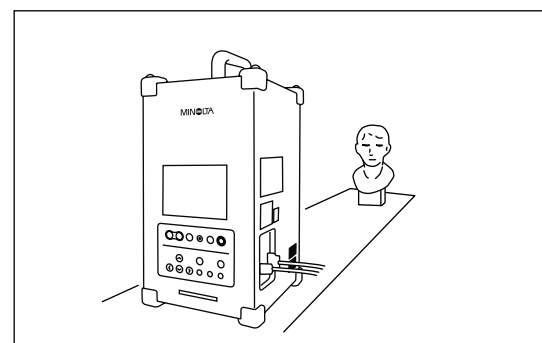
The scan subject must appear at the center of the screen to ensure that scanning is carried out correctly. If the subject is not centered it is possible that scanning may not execute correctly.





- 5 To see the color image, press**  **.**
A color still image captured when  was pressed will appear.

Note

If the distance or angle to the object has been changed, press  again to display the monochrome image to check it.

Memo

If the captured image is too light or too dark, the color level may need to be adjusted. You can temporarily adjust the level by pressing  or  while viewing the image.

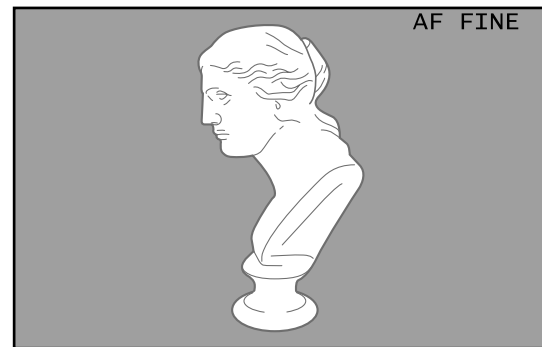

- 6 Press**  **and select the desired scan mode.**

<Settings>

- **FINE:** Scans with high resolution and accuracy. (2.5 seconds, 640 × 480)
- **FAST:** Scans at a high speed. (0.3 seconds, 320 × 240)

Memo

The resolution of color images will always be 640 × 480 regardless of the scan mode.

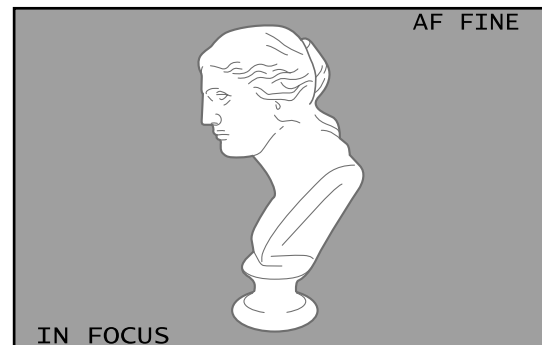

- 7 Press**  **.**

The VIVID 910 will perform auto-focus, cause the laser beam to scan the object surface, and complete acquisition of range and color images. The scan results (range and color images) will be displayed on the viewfinder.

Memo

When scanning just after the mode is switched from FINE to FAST or vice versa, the motor will start rotation to set the laser beam first and then focus is performed.

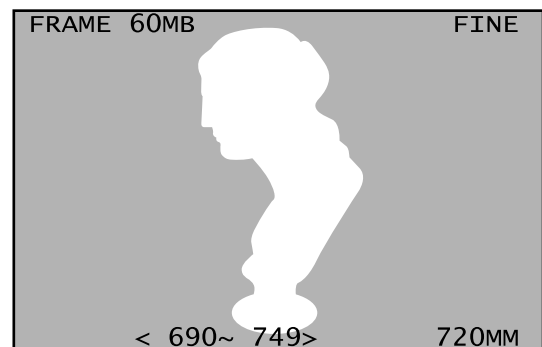

[Ref.] > For a description of displaying the scan results, refer to page 32.

Note

- *With certain objects, "AF/AE ERROR" will be displayed, indicating that auto-focus cannot be performed. In this case, press any key to clear the error view, then set focus lock or perform manual focus.*
- *While scan is in progress, never insert/remove the memory card or press any keys. Doing so may cancel scan or hinder acquisition of correct data.*



[Ref.] · For a description of focus lock, refer to page 35.
· For a description of manual focus, refer to page 36.

- 8 Check the images, and if you want to save them press**  **.**

[Ref.] > For a description of saving the image in a file, refer to page 47.

Note

The acquired data will be deleted if the following operations are performed. If you need the data, it must be saved before performing the following operations.

-  is pressed.
-  or  is pressed to return to the monitor (real-time image) view.

- *The lens is replaced.*
- *The power switch is set to OFF.*

9 To scan again, repeat steps 1 to 8.

[Memo]

If the scan results are not satisfactory, try the following:

- Adjust the laser power manually.
- Adjust the CCD gain.
- Set the scan reference distance.
- Adjust white balance.

[Ref.]

- For a description of adjusting the laser power and CCD gain, refer to page 37.
- For a description of setting the scan reference distance, refer to page 39.
- For a description of adjusting white balance, refer to page 43.

Displaying the Scan Results

When an image is captured, scan results (range image data) will be displayed on the viewfinder.

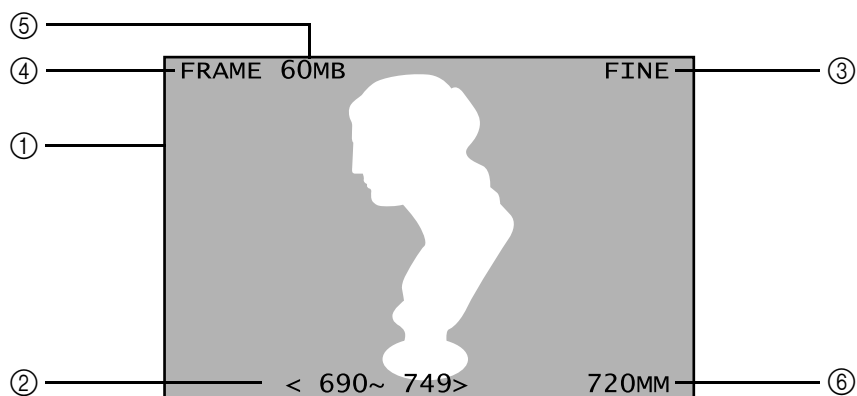

- ① **Range image**
- ② **Effective scan range (back-forth direction)**Displays the allowed scan range.
- ③ **Scan mode**Displays the scan mode (FINE or FAST).
- ④ **File name**Displays the file name set in “AUTO []” of “FILE NAME” in the CARD SETTING view.
No file name will be displayed if “INTERACTIVE” has been selected.
- ⑤ **Remaining memory capacity**.....Displays the remaining capacity of the memory card (in MB).
- ⑥ **Scan reference position**Displays the distance from the front of the lens to the focus position.

Pressing ◀ or ▶ will display the color image data on the viewfinder. Pressing it again will display the range image data.

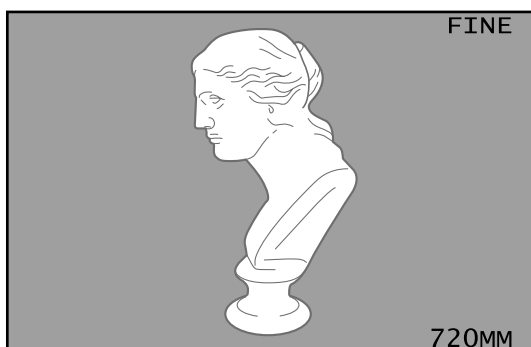

High Quality Mode

The instrument emits a laser beam on the object, and captures the rays reflected from the object using the CCD for measurement.

Thus, for better measurement accuracy, it is necessary for the intensity of the reflected rays to be maintained within the CCD's measurement range (i.e. the range that ensures linearity).

In high quality mode, the parts of the reflected rays that are outside the CCD's measurement range will be eliminated, so that only the data with assured linearity is output.

This provides measured data with higher accuracy than that which includes reflected rays outside the linearity range.









Memo

If the instrument is set to High Quality Mode when you read in memory-card data that was scanned at a VIVID 910, the instrument will automatically eliminate all data values that are outside the measurement range. This will be true even if High Quality Mode was not turned on at the time the original data were scanned.

Note

When reading in memory-card data that was scanned at a VIVID 900, the instrument will not eliminate data values that are outside the measurement range.

[Operating Procedure]

- 1 Press .
The MENU view will appear.
- 2 Press   to locate the arrow cursor to "CAMERA SETTINGS".
- 3 Press .
The CAMERA SETTINGS view will appear.
- 4 Press   to locate the arrow cursor to "HIGH QUALITY MODE".
- 5 Press .
The currently selected high quality mode (ON or OFF) will turn to pink.
- 6 Press   to select "ON" or "OFF".

<Settings>

- ON: High quality mode
- OFF: Digitize mode (normal measurement mode)

SCAN
FILE LIST
→CAMERA SETTINGS
CARD SETTINGS
INFO

CLOCK	FEB.04.2000
	16:21:58
W/B	DEFAULT
SCSI ID	5
TERMINATE	ENABLE
AUTO READ	ON
COLOR	AUTO
→HIGH QUALITY MODE	OFF

CLOCK	FEB.04.2000
	16:21:58
W/B	DEFAULT
SCSI ID	5
TERMINATE	ENABLE
AUTO READ	ON
COLOR	AUTO
HIGH QUALITY MODE	OFF

7 Press .

The procedure is now complete.

Memo

- If high quality mode is set to OFF (digitize mode), data outside the measurement range will be displayed in yellow on the range image.
- If high quality mode is set to ON, data outside the measurement range will be eliminated, therefore it will not be displayed on the screen.
- If the part that you want to input is displayed in yellow or does not appear as the range image in the display at all, press  to cancel the scan. Then adjust the laser power and gain setting and try scanning again.

Setting Focus Lock

With certain objects, “AF/AE ERROR” will be displayed at the end of a scan, indicating that auto-focus cannot be performed.

In this case, press any key to clear the error view, then set focus lock as described below.

[Memo]

The VIVID 910 uses contrast detection type auto focus. Auto focus may not be possible with the following objects:

- White wall etc. whose contrast is low
- Objects with repetitive patterns (stripes etc.)

To scan such objects, set focus lock or perform manual focus. (Since focus lock performs active auto focus using a laser beam, low-contrast objects can still be auto-focused.)

[Ref.] For a description of manual focus, refer to page 36.

[Operating Procedure]

The following procedure applies only if an error has occurred when a scan was performed as explained on page 30.

- 1 Press any key to clear the error view.
- 2 Remove the current object and place a new object that can be easily auto-focused in the same position.

[Memo]

It is recommended that a paper with a contrasting pattern such as a large character be affixed to the object.

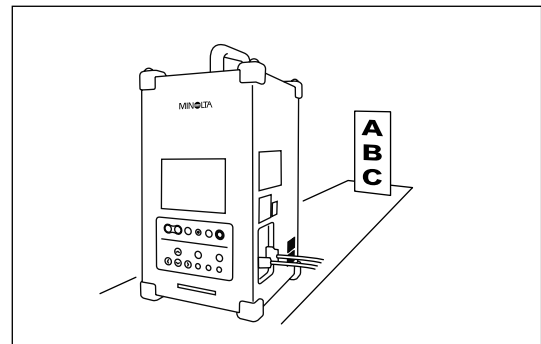

- 3 Press . “FOCUS LOCK” will be displayed on the viewfinder, and the focus will be locked when the object is focused.

[Memo]

To release focus lock, press ,  or . (The result from pressing them will vary depending on the key pressed.)

- 4 Replace the object with the original one and perform a scan.

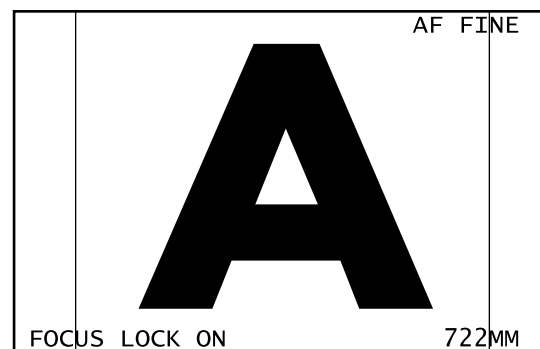

Setting Manual Focus

With certain objects, “AF/AE ERROR” will be displayed at the end of a scan, indicating that auto-focus cannot be performed.

In this case, press any key to clear the error view, then set manual focus as described below.

[Memo]

Auto focus may not be possible with the following objects:

- White wall etc. whose contrast is low
- Objects with repetitive patterns (stripes etc.)

To scan such objects, set focus lock or perform manual focus.

[Ref.] For a description of focus lock, refer to page 35.

[Operating Procedure]

- 1 Measure the distance to the object with a measuring tape.**

[Memo]

Although the front of the lens is the reference position, this position varies with the type of lens, so measure the distance from the front of the VIVID 910.

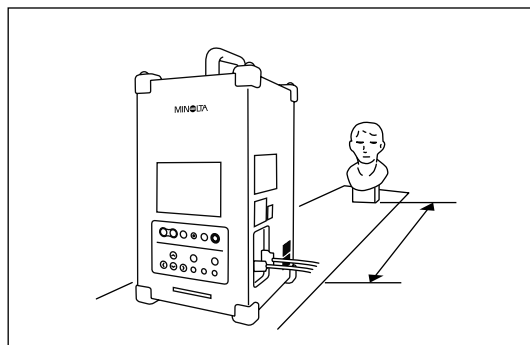

- 2 Press .**

Manual focus mode will be active.

[Memo]

To cancel manual focus, press  again.

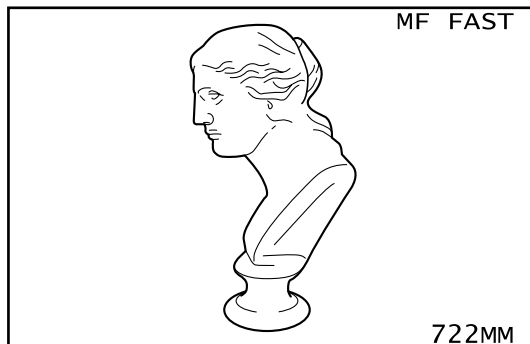

- 3 Press  and set the scan distance.**

Pressing F will move the focus position far away from you.

Pressing N will move the focus position toward you.

- 4 When the scan distance is set, start scanning.**

Adjusting the Laser Power and CCD Gain Manually

With certain objects, correct image data cannot be obtained.

In this case, press  at the end of scan, and adjust the laser power and CCD gain as explained below.

Memo



With the following objects, correct data may not be acquired:

- Glass etc. which transmit light
- Mirrors etc. which cause mirror reflection
- Electric bulbs etc. which themselves illuminate
- Black or blue cloth which has a low reflectance for red and similar colors

To scan these objects, the laser power or CCD gain must be adjusted manually.

[Operating Procedure]



The following procedure must be carried out if images acquired when scan was performed as explained on page 30 are unsatisfactory.



- 1 Press  at the end of scan.**
The currently set laser power will turn to pink.
- 2 Press   to set the desired laser power.**

<Settings>

- **0 to 255:** Laser beam power

Memo

Pressing   will change the value in steps.

- 3 Press .**
The laser power will be set.
Next, the currently set CCD gain will turn to pink.
- 4 Press   to set the desired CCD gain.**

<Settings>

- **0 to 7:** CCD gain

Memo

The CCD gain must be adjusted only if satisfactory scan results still cannot be obtained even though the laser power has been set to the maximum.

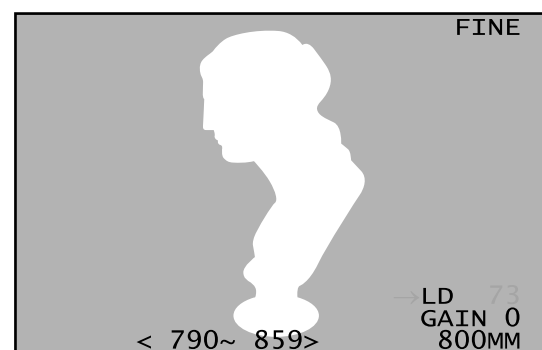



- 5** Press  .
 The CCD gain will be set.
 Next, the currently set scan reference distance will turn to pink.

 For a description of setting the scan reference distance, refer to page 39.



- 6** Press  .
 The monochrome image currently captured by the VIVID 910 will be focus-locked and displayed in real time on the viewfinder.

 A color still image can also be displayed by pressing  .

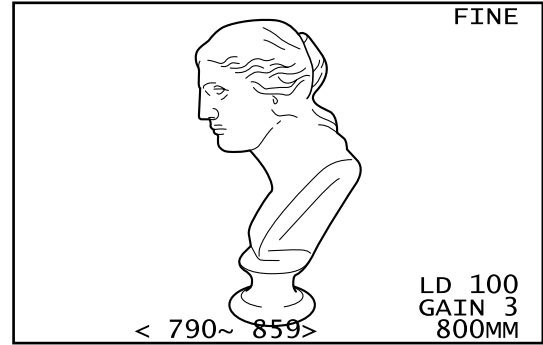

- 7** Press  .
 Scan will be performed with the newly set laser power and CCD gain.

Setting the Scan Reference Distance

If the entire object is not completely within the effective scan range and a part of the front or back of the object is not scanned, press  at the end of scan, shift the reference position back or forth as described below, then perform scan again.

[Operating Procedure]

The following procedure must be carried out if images acquired when scan was performed as explained on page 30 are unsatisfactory.

- 1 Perform scan and press  at the end of scan.**
The currently set laser power will turn to pink.

[Ref.] For a description of adjusting the laser power, refer to page 37.





- 2 Press .**
The currently set CCD gain will turn to pink.

[Ref.] For a description of adjusting the CCD gain, refer to page 37.



- 3 Press .**
The currently set scan reference distance will turn to pink.

- 4 Press   and set the desired scan reference distance.**

If the acquired image lacks a front part of the object, set the scan reference distance closer to you.

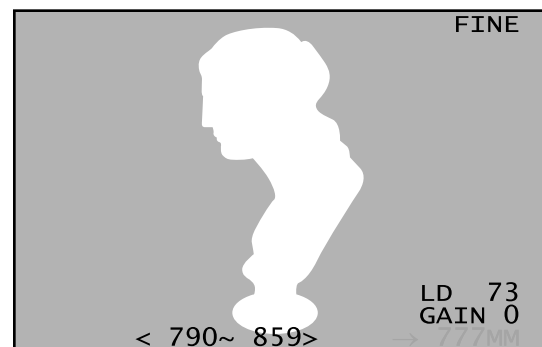

If the acquired image lacks a back part of the object, set the scan reference distance away from you.



<Settings>

- 600 to 2500: Scan reference distance (Unit: mm)

[Memo]

Pressing   will change the value in steps.

5 Press  .

The monochrome image currently captured by the VIVID 910 will be focus-locked and displayed in real time on the viewfinder.

[Memo]

A color still image can also be displayed by pressing  .

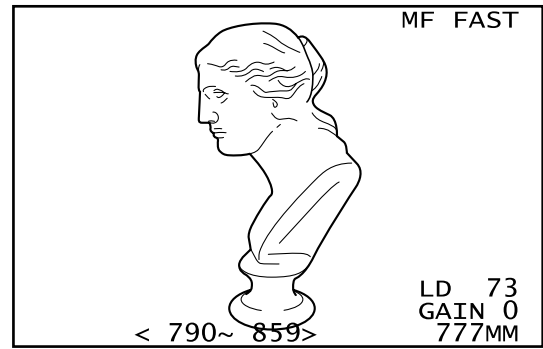

6 Press  .

Scan will be performed with the newly set scan reference position.

[Memo]

If the acquired image still lacks a front or back part of the object, try the following:

- If you are using the TELE or MIDDLE lens, replace it with the WIDE lens and perform scan.
- Increase the distance from the VIVID 910 to the object and perform scan.
- Perform scan from different angles to acquire multiple images.
- Perform scan in FINE mode.

Setting Auto Read

With certain objects, a better image can sometimes be acquired if the condition of the laser beam emitted to scan a range image differs from that emitted to scan a color image. In this case, set Auto Read to OFF as explained below.

[Operating Procedure]

1 Press .
The MENU view will appear.

SCAN
FILE LIST
→CAMERA SETTINGS
CARD SETTINGS
INFO

2 Press   to locate the arrow cursor to "CAMERA SETTINGS".

3 Press .
The CAMERA SETTINGS view will appear.

CLOCK	FEB.04.2000 16:21:58
W/B	DEFAULT
SCSI ID	5
TERMINATE	ENABLE
→AUTO READ	ON
COLOR	AUTO
HIGH QUALITY MODE	OFF

4 Press   to locate the arrow cursor to "AU-TO READ".



5 Press .
The currently set auto read mode (ON or OFF) will turn to pink.

CLOCK	FEB.04.2000 16:21:58
W/B	DEFAULT
SCSI ID	5
TERMINATE	ENABLE
AUTO READ	ON
COLOR	AUTO
HIGH QUALITY MODE	OFF

6 Press   to select "OFF".

7 Press .
Auto Read mode will be set to OFF.

Memo

If Auto Read is set to OFF, no color image will be scanned even though  is pressed to scan. To scan a color image, press  again.



Setting the Color Level

The exposure level (brightness/darkness) used for scanning color images can be set.

[Operating Procedure]



1 Press .
The MENU view will appear.

SCAN
FILE LIST
→CAMERA SETTINGS
CARD SETTINGS
INFO

2 Press   to locate the arrow cursor to "CAMERA SETTINGS".

3 Press .
The CAMERA SETTINGS view will appear.

CLOCK	FEB.04.2000 16:21:58
W/B	DEFAULT
SCSI ID	5
TERMINATE	ENABLE
AUTO READ	ON
→COLOR	AUTO
HIGH QUALITY MODE	OFF

4 Press   to locate the arrow cursor to "COLOR".

5 Press .
The currently set color level will turn to pink.

CLOCK	FEB.04.2000 16:21:58
W/B	DEFAULT
SCSI ID	5
TERMINATE	ENABLE
AUTO READ	ON
COLOR	AUTO
HIGH QUALITY MODE	OFF



6 Press   to set the desired laser power.

<Settings>

- **AUTO:** Scans a color image with the same exposure level as the one for monochrome images.
- **0 to 9:** The larger the value, the brighter the image.

7 Press .
The new color level will be set.

Memo

While checking the color image by pressing  before starting scan, it is possible to change the color level temporarily by pressing  .

Adjusting the White Balance

The color of an object varies slightly depending on the type of light source. To acquire accurate color image data, adjust the white balance as described below under the light source to be used.

When scanning, we recommend that you use a stable, flicker-free light source (such as a high-frequency fluorescent lamp).

Memo

The white balance has been adjusted under fluorescent light before shipment.

[Operating Procedure]

1 Set the light source so that the lighting condition is the same as that under which scan is to be performed.

2 Attach the white balance cap to the VIVID 910 as illustrated.

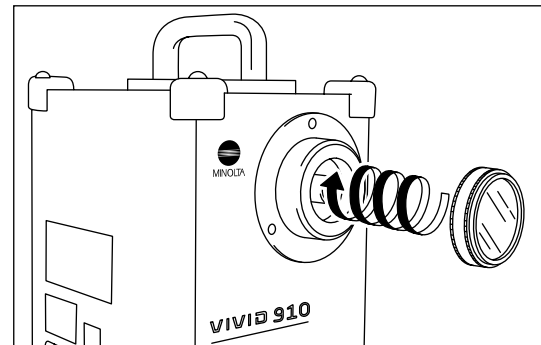

3 Press . The MENU view will appear.

4 Press   to locate the arrow cursor to "CAMERA SETTINGS".

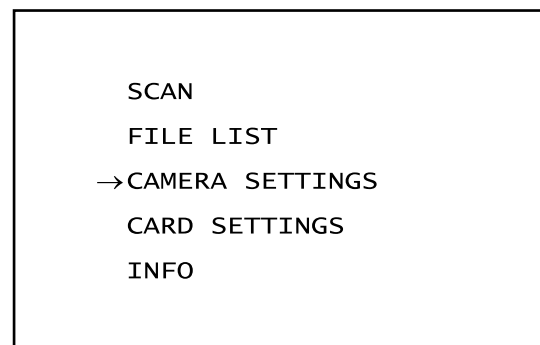

5 Press . The CAMERA SETTINGS view will appear.

6 Press   to locate the arrow cursor to "W/B".

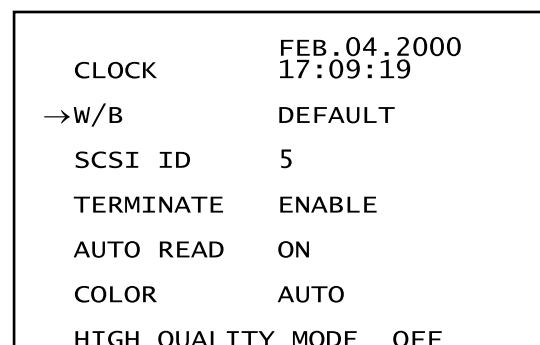

7 Press .

8 Press   to select "CALIBRATE".

CLOCK	FEB.04.2000 17:09:19
W/B	CALIBRATE
SCSI ID	5
TERMINATE	ENABLE
AUTO READ	ON
COLOR	AUTO
HIGH QUALITY MODE	OFF

9 Press .

"CALIBRATING" will be displayed and white balance will be adjusted.

Memo

If "DEFAULT" is selected and  is pressed at step 6, the default white balance (i.e. calibrated under fluorescent light) will be restored.

Data File Management

The acquired image data can be saved in an optional memory card. Once the data is saved, it can be loaded to the VIVID 910 or to a computer using the Polygon Editing Tool.

[Memo]

Insert the compact flash card into the PC card adapter, then insert them into the memory card slot on the VIVID 910.

[Note]

The memory card (compact flash card VI-A12 + PC card adapter VI-A13) supplied with the VIVID 910 must be used.

[Ref.]



For a description of the memory card, refer to page 21.

Selecting the File Name Input Method

Two methods are available for assigning a file name to image data when saving it: “AUTO” to assign file names automatically, and “INTERACTIVE” to assign them interactively.

[Operating Procedure]

1 Press .
The MENU view will appear.

2 Press   to locate the arrow cursor to “CARD SETTINGS”.

3 Press .
The currently selected method will be displayed.

<Settings>

- **AUTO <FRAME>:**
Automatically adds a serial number (001 to 999) to the prefix file name (up to five characters) specified in “<>” and saves the data.
- **INTERACTIVE:**
Asks you to enter a file name each time you attempt to save the data. (A view asking you to enter a file name will appear each time you attempt to save the data.)

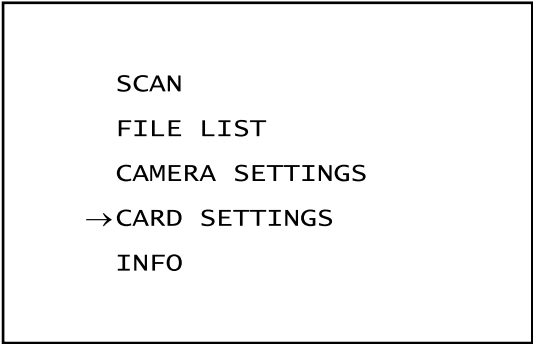

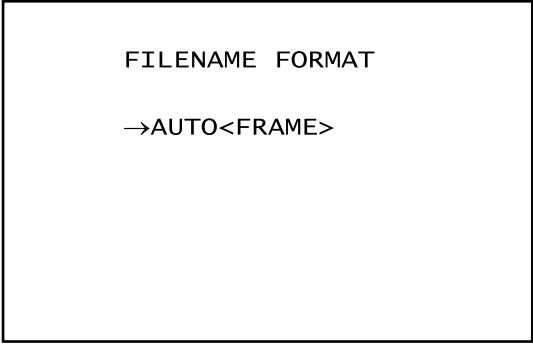

```
SCAN
FILE LIST
CAMERA SETTINGS
→CARD SETTINGS
INFO
```





```
FILENAME FORMAT

→AUTO<FRAME>
```



- 4** Press  .
The currently selected method will turn to pink.
- 5** Press   to select the desired method.



```
FILENAME FORMAT
AUTO<FRAME>
```

- 6** Press  .
The selected method will be set.
If “INTERACTIVE” is selected, selection of file name input method is now complete.
If “AUTO” is selected, proceed to step 7.

- 7** If “AUTO” is selected, select the character to be changed from the prefix file name displayed in < > by pressing   .

[Memo]

Moving through the prefix file name from one character to another by pressing , the character located right on  will be cleared.

- 8** Press   to select the desired new character.

[Memo]

Characters can be selected from alphabets (A to Z) and numbers (0 to 9).

- 9** Repeat steps 7 and 8 to complete the new prefix file name (up to five characters).

- 10** Press  .
The specified file name will be set.

```
FILENAME FORMAT
AUTO<FRA >
```

Saving a File

The acquired data can be saved in a file to the memory card as described below.



[Operating Procedure]

1 Performs a scan.

[Ref.] For a description of scan, refer to page 30.

2 Press .

[Note]

If you have checked the color image data after scanning, press   to switch to the range image view before this step. The RECORD key is not effective while the color image is displayed.

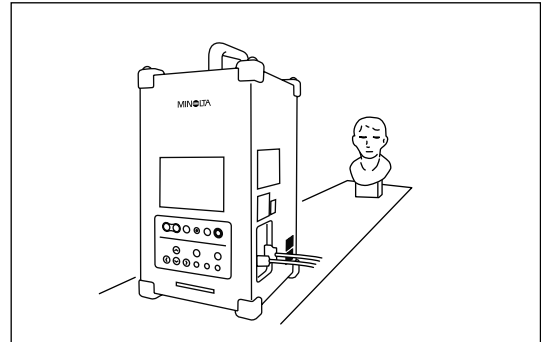

The procedure varies with the file name input method.

[Ref.] For a description of file name input method, refer to page 45.

If “AUTO” file name input method has been selected, “RECORDING” will be displayed and the data will be saved.

If “INTERACTIVE” file name input method has been selected, proceed to step 3.

3 If “INTERACTIVE” file name input method has been selected, press to specify the desired file name.



[Memo]

Characters can be selected from alphabets (A to Z) and numbers (0 to 9).



4 Press to select the character to be changed.

[Memo]

Moving through the prefix file name from one character to another by pressing , the character located right on  will be cleared.

5 Repeat steps 3 and 4 to complete the file name (up to eight characters).

6 Press .

“RECORDING” will be displayed and the data will be saved under the specified file name.

Loading a File

Data saved in the memory card can be loaded as described below.

[Operating Procedure]

1 Press .
The MENU view will appear.

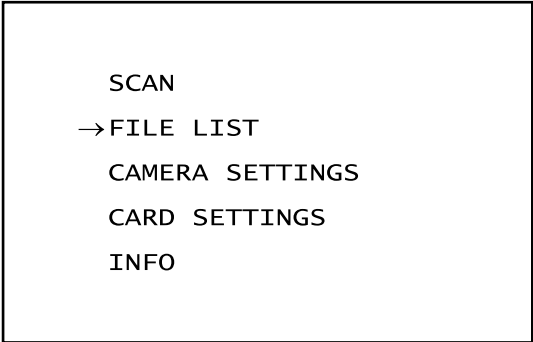

2 Press to locate the arrow cursor to "FILE LIST".

3 Press .
The FILE LIST view will appear.

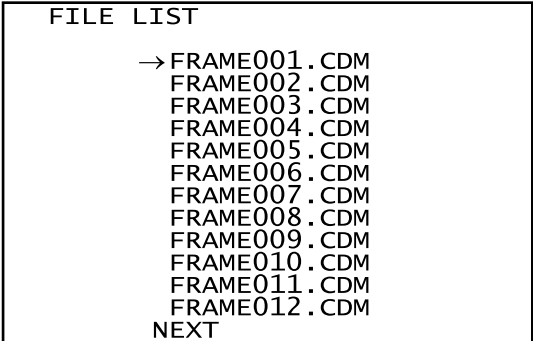

Note
The data obtained by step shot scan using the Polygon Editing Tool Software (the instrument is connected to a personal computer) will not be displayed.

4 Press to select the file you want to load.

5 Press to check the information regarding the selected file.
"LOADING" will be displayed, and the following views will appear.

Memo

- Each time is pressed, the view will switch as follows. Even if a view is currently displayed, you can still display file information of other files listed in the FILE LIST view by pressing .

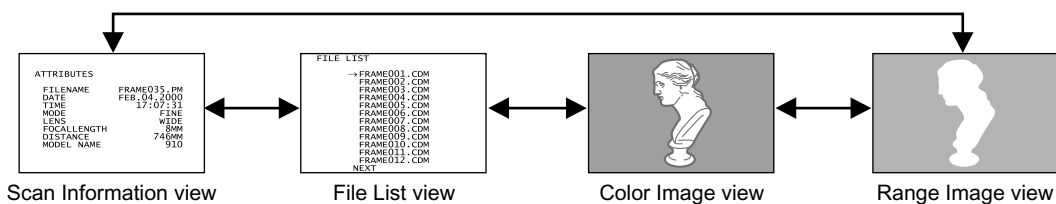

- The following information can be checked in the Scan Information view.

File name		Saved date		Scan mode		Scan lens		Scan distance		Machine that took the scan	
FILENAME	FRAME035.PM	DATE	FEB.04.2000	MODE	FINE	LENS	WIDE	FOCAL LENGTH	8MM	DISTANCE	746MM
		TIME	17:07:31					MODEL NAME	910		

Changing a File Name

File names of the data stored in the memory card can be changed.

[Operating Procedure]

1 Select the data whose file name is to be changed.

[Ref] > For a description of selecting a file, refer to page 48.

2 Press .

A file edit view will appear.

```

SELECTED FILE

FRAME020.CDM

→CHANGE FILENAME
DELETE FILE
  
```

3 Press to locate the arrow cursor to "CHANGE FILENAME".

4 Press .

The last character of the selected file name will turn to pink.

```



SELECTED FILE

FRAME020.CDM

→CHANGE FILENAME
DELETE FILE
> FRAME020
  
```

5 Press to select the character to be changed.

[Memo]

Moving through the prefix file name from one character to another by pressing , the character located right on  will be cleared.

6 Press to select the desired new character.

[Memo]

Characters can be selected from alphabets (A to Z) and numbers (0 to 9).

7 Repeat steps 5 and 6 to complete the desired file name.

[Memo]

To cancel changing the file name and restore the original file name, press .

8 Press .

The file name will be changed.

The view shown at step 1 will reappear.

Deleting a File

Files stored in the memory card can be deleted.

[Operating Procedure]

1 Select the file you want to delete.

[Ref>] For a description of selecting a file, refer to page 48.

2 Press .

A file edit view will appear.

3 Press to locate the arrow cursor to “DELETE FILE”.

```

SELECTED FILE

FRAME020.CDM

CHANGE FILENAME
→DELETE FILE
  
```

4 Press .

The selected file name will turn to pink, and “CONFIRM TO DELETE?” will be displayed.

[Note]

Once a file is deleted, it cannot be restored any more. Thus, before deleting it, double-check its file name etc.

If you do not want to delete, press .

```

SELECTED FILE

FRAME020.CDM

CHANGE FILENAME
→DELETE FILE
> CONFIRM TO DELETE?
  
```

5 Press .

The file will be deleted.

The FILE LIST view will reappear.

Displaying the Status Information

The model name, version, lens information, total capacity and unoccupied capacity of the memory card can be displayed.

[Operating Procedure]

1 Press .
The MENU view will appear.

2 Press   to locate the arrow cursor to “INFO”.

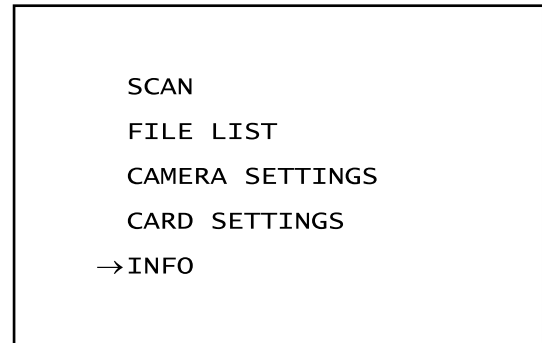

3 Press .
The status information will be displayed as shown below.

CAMERA

- **MODEL NAME:** Model name (VIVID 910)
- **VERSION:** Version No.
- **S/N:** Serial No.

LENS

- **TELE S/N:** TELE lens's serial No.
- **MIDDLE S/N:** MIDDLE lens's serial No.
- **WIDE S/N:** WIDE lens's serial No.
- *****: Indicates the currently installed lens.

PC CARD

- **TOTAL SPACE:** Total capacity of memory card
- **FREE SPACE:** Unoccupied capacity of memory card

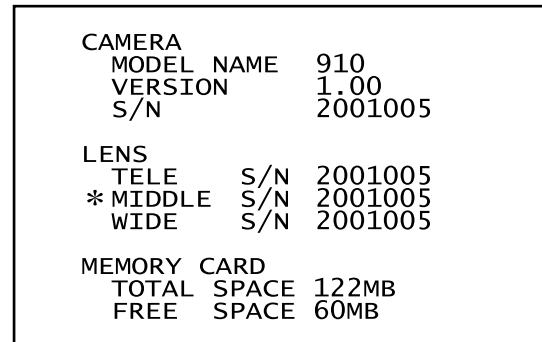



Chapter 4

Appendix



Error Messages

The following error messages appear if incorrect operation is performed or an abnormality occurs with the VIVID 910. If an error message appears, take the appropriate corrective actions as shown in the table below. If the problem still does not disappear, contact a Minolta-authorized service facility.

Error Message (Alphabetically)	Meaning	Action
AF/AE ERROR LASER BARRIER MAY BE CLOSED PRESS ANY KEY	Auto-focus or auto-exposure failed. Press any key.	Remove the laser cap. In the case of an object for which it is difficult to acquire correct images, set the focus lock or manual focus.
AF ERROR LOW CONTRAST PRESS ANY KEY	Auto-focus failed due to low contrast of the object. Press any key.	In the case of an object for which it is difficult to acquire correct images, set the focus lock or manual focus.
BACKUP ERROR PRESS ANY KEY	Failed to back up the data. Press any key.	All the settings will be initialized, so set them again.
CAUTION LASER SCANNER IS OUT OF ORDER PLEASE TURN OFF	The laser beam is not emitted properly. Turn off the power immediately.	Highly dangerous! Turn off the power immediately and contact a Minolta-authorized service facility.
CHANGE LENS TELE S/N ***** MIDDLE S/N ***** WIDE S/N ***** PRESS ANY KEY	The lens is now being replaced. Press any key.	Attach the lens hood properly. Check the serial No. of the lens, and replace the lens properly.
CLOCK ERROR PRESS ANY KEY	The clock is abnormal. Press any key.	The date/time data will be initialized, so set it again.
DIRECTORY FULL PLEASE INSERT ANOTHER MEMORY CARD OR PRESS ANY KEY	The maximum allowed number of files has already been stored. Replace the compact flash card with a new one, or press any key.	Insert a memory card that has sufficient unoccupied memory capacity. Delete files from the currently inserted memory card.
ERROR OUT OF DISTANCE RANGE PRESS ANY KEY	The object is not located within the specified object distance range. Press any key.	Place the object in a position 0.5 m to 2.5 m away from the VIVID 910.
INVALID FORMAT PLEASE INSERT ANOTHER MEMORY CARD OR PRESS ANY KEY	The memory card has not been initialized. Press any key.	Insert an initialized memory card into the slot or initialize the current memory card. (It is not possible to initialize a memory card using the VIVID 910.)
LIGHT IMPROPER	Insufficient amount of light	Illuminate the object brighter and scan it.
NO FREE SPACE PLEASE INSERT ANOTHER MEMORY CARD OR PRESS ANY KEY	There is insufficient unoccupied capacity on the memory card. Press any key.	Insert a memory card that has sufficient unoccupied memory capacity. Delete files from the currently inserted memory card.
NO MEMORY CARD PLEASE INSERT A CARD OR PRESS ANY KEY	No memory card is inserted. Insert another memory card or press any key.	Insert a memory card into the slot.

Error Message (Alphabetically)	Meaning	Action
MEMORY CARD IS EJECTED PRESS ANY KEY	The memory card has been ejected. Press any key.	Insert a memory card into the slot.
MEMORY CARD IS EJECTED RECORDING IS CANCELED PRESS ANY KEY	The memory card has been ejected. Press any key.	Insert a memory card into the slot.
SAME FILE NAME	A file of the same file name already exists.	Specify another file name.
SYSTEM ERROR PLEASE TURN OFF	A system error has occurred. Turn OFF the power.	Turn OFF the power, then turn it ON again. If the problem still does not disappear, contact a Minolta-authorized service facility.
TERMINATE ERROR PRESS ANY KEY SET TERMINATE ENABLE	SCSI terminator error has occurred. Press any key and set the terminator to "ENABLE".	Set the terminator to "ENABLE".
UNKNOWN MEMORY CARD PLEASE INSERT ANOTHER MEMORY CARD OR PRESS ANY KEY	The currently inserted memory card is not suitable for the VIVID 910. Insert another memory card or press any key.	Insert a suitable memory card into the slot.
WB ERROR LIGHT IMPROPER PRESS ANY KEY	Failed to adjust white balance. Press any key.	Adjust white balance in a bright place. (White balance in effect before occurrence of this error has not been updated.)

Explanation of Measuring Principle

Measuring Principle

The VIVID 910 uses the light-stripe method to emit a horizontal stripe light through a cylindrical lens to the object. The reflected light from the object is received by the CCD, and then converted by triangulation into distance information.

This process is repeated by scanning the stripe light vertically on the object surface using a Galvano mirror, to obtain a 3D image data of the object.

In addition, a color image of the object is also obtained by scanning the CCD through a RGB filter while the stripe light is not emitted. (A band pass filter is used when stripe light is emitted.)

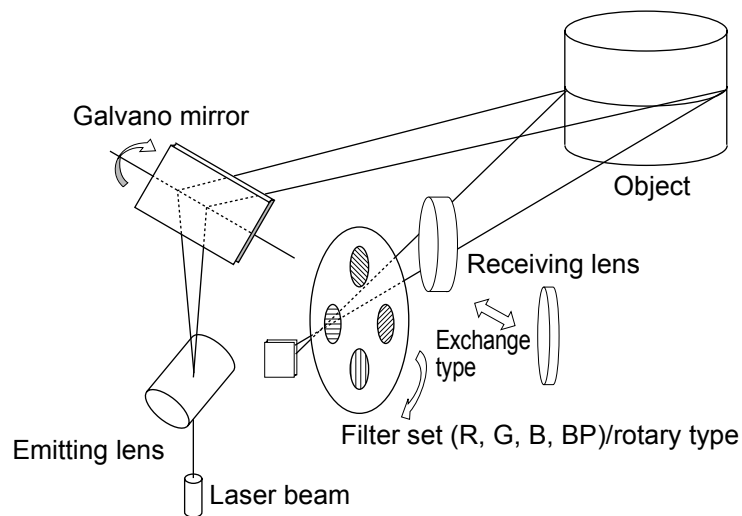

High-Speed Image Processing Circuit

The stripe light is scanned on the CCD image plane at two horizontal lines per frame (FAST mode) or one horizontal line per frame (FINE mode), and the CCD is driven so that the block readout start position is shifted two lines per frame (FAST mode) or one line per frame (FINE mode).

Approximately 270 frames of the imager are acquired in FAST mode, whilst approximately 600 frames are acquired in FINE mode.

- CCD drive rate: 12.5MHz
- Block readout: 36 lines (FAST mode)/125 lines (FINE mode)
- Data acquisition speed: 0.3 sec. (FAST mode)/2.5 sec. (FINE mode)

The output signal from the CCD is then converted into a digital signal, which is then subjected to digital signal processing. The signal processed data is finally saved in the frame memory.

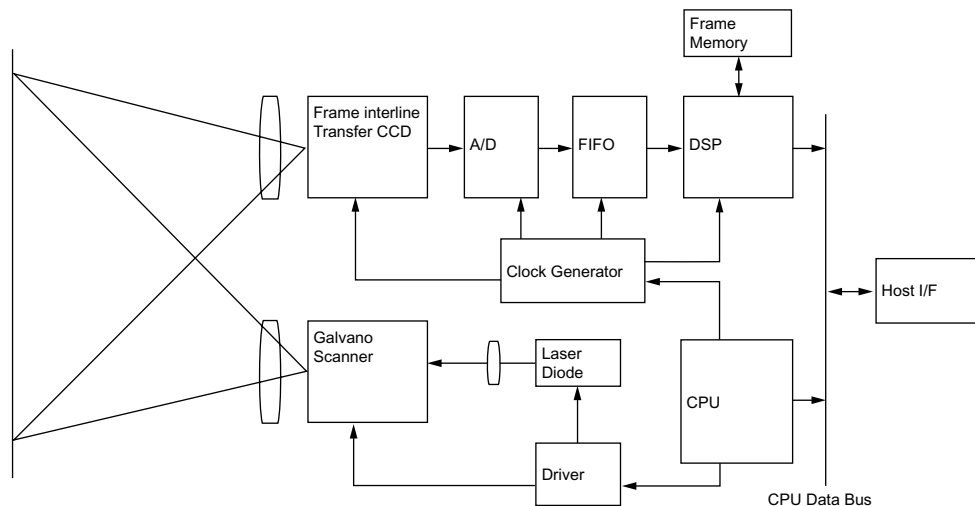

Time center of gravity and Space center of gravity

Time center of gravity is the center of gravity of the variation in the LD light passing CCD's one picture element over a period of time.

Space center of gravity is the center of gravity of the spatial variation in the LD light on the CCD at a certain time.

With this instrument, 3D images are obtained by calculating the Time center of gravity of each picture element of CCD. Intersection of the viewing angle of each picture element of the CCD and passing angle (time) of the stripe light is calculated.

Compared to the Space center of gravity, use of Time center of gravity can reduce influences of sensitivity variation of CCD's picture elements and variation of brightness of the object.

Dimension Diagram

(Unit: mm)

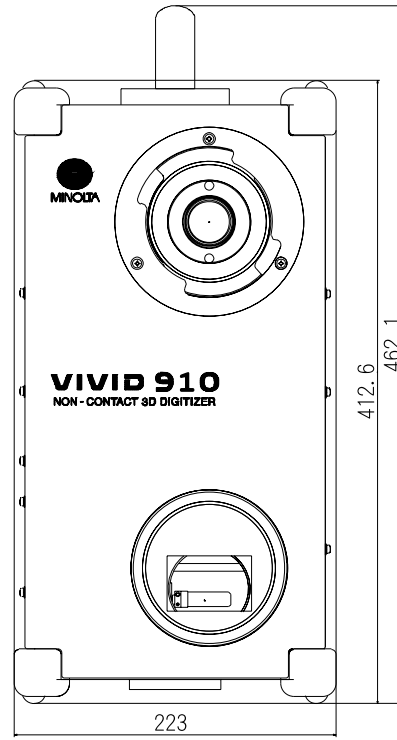
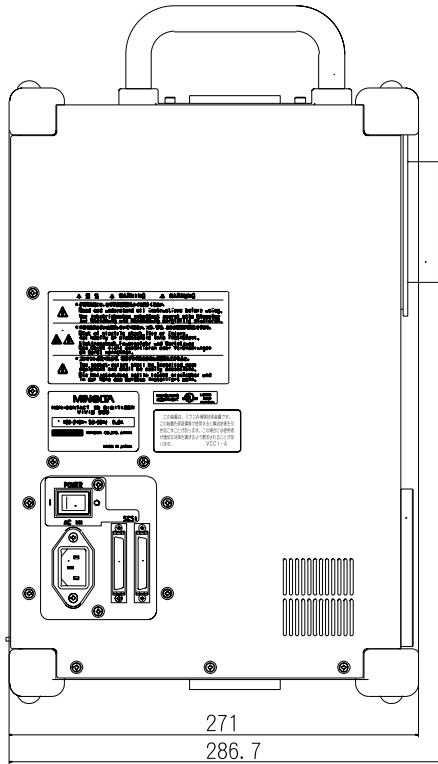

Specifications

Model Name	Non-contact 3D digitizer VIVID 910/VI-910
Measurement Method	Triangulation, light-stripe method
AF	Image surface AF (contrast method), Active AF
Light-Receiving lens (exchangeable)	TELE : Focal distance $f=25$ mm MIDDLE: Focal distance $f=14$ mm WIDE : Focal distance $f=8$ mm
Object Distance Range	0.6 to 2.5 m (2 m for WIDE lens)
Field of View	0.6 to 1.2 m
Laser Power	Max. 30 mW, 690 nm *IEC Class 2 (for Europe) with IEC PUBLICATION 60825-1:1993, Amendment-1:1997 *FDA Class I (for US.) with 21CFR chapter 1, Subchapter J.
Laser Scanning Method	Galvano mirror
Scan Mode	FAST (high-speed mode)/FINE (high-accuracy mode) High quality mode Dynamic range mode (Selectable when measurement is taken using the Polygon Editing Tool Software (standard accessory))
X Direction Input Range (Varies with the distance)	111 to 463 mm (TELE), 198 to 823 mm (MIDDLE), 359 to 1196 mm (WIDE)
Y Direction Input Range (Varies with the distance)	83 to 347 mm (TELE), 148 to 618 mm (MIDDLE), 269 to 897 mm (WIDE)
Z Direction Input Range (Varies with the distance)	40 to 500 mm (TELE), 70 to 800 mm (MIDDLE), 110 to 750 mm (WIDE/FINE mode)
Accuracy	TELE X: ± 0.22 mm, Y: ± 0.16 mm, Z: ± 0.10 mm to the Z reference plane MIDDLE X: ± 0.38 mm, Y: ± 0.31 mm, Z: ± 0.20 mm to the Z reference plane WIDE X: ± 1.40 mm, Y: ± 1.04 mm, Z: ± 0.40 mm to the Z reference plane (Conditions: FINE mode, distance 0.6 m, Minolta's standard 3D chart, Minolta's processing software, temperature 20°C, relative humidity 65% or less)
Precision (Z, σ , Typ.)	TELE 8 μ m, MIDDLE 16 μ m, WIDE 32 μ m (Conditions: FINE mode, distance 0.6m, Minolta's standard 2D chart, Minolta's processing software, temperature 20°C, relative humidity 65% or less)
Input Time	0.3 sec. (FAST mode), 2.5 sec. (FINE mode), 0.5 sec. (COLOR)
Image Data Transfer Time to Computer	Approx. 1 sec. (FAST mode), 1.5 sec. (FINE mode)
Allowed Environmental Light	500 lx or less
Imaging Device	3D data : 1/3-inch frame transfer CCD (340,000 picture elements) Color data : 3D data is shared (color separation by rotary filter)
Output Data Points	3D data : 640 \times 480 (FINE mode) 320 \times 240 (FAST mode) Color data : 640 \times 480
Output Format	3D data : Original format (Converted to 3D by the standard utility software) Color data : RGB 24-bit raster scan data
Memory Media	ATA PC card Type II
Data Capacity	1.6MB/card (FAST mode), 3.6MB/card (FINE mode) (in total of 3D data and color data)
Viewfinder	5.7-inch LCD (320 \times 240 picture elements)
Output Interface	SCSI II (DMA synchronous transfer)
Power	100 to 240V \sim (50/60Hz), 0.6A (at 100V \sim)

Specifications

Model Name	Non-contact 3D digitizer VIVID 910/VI-910
Dimensions	213 (W) × 413 (H) × 271 (D) mm
Mass	Approx. 11 kg
Operating environment	Operating Temperature Range: 10 to 40°C; 65% RH or less/no condensation; Installation category: II; Pollution degree: 2; Maximum altitude: 2000 m
Storage Temperature Range	-10 to 50°C, 85% or less (at 35°C)/no condensation

The above specifications are subject to change without prior notice.

