

# Display Color Analyzer **CA-410** Probe + Data Processor **CA-DP40**

## Instruction Manual



Please read before  
using the instrument.



KONICA MINOLTA

## ■ Safety Symbols

The following symbols are used in this manual to prevent accidents that may occur because of incorrect use of the instrument.



Denotes an instruction regarding a safety warning or note.  
Read the instruction carefully to ensure safe and correct use.



Denotes an instruction regarding the risk of electric shock.  
Read the instruction carefully to ensure safe and correct use.



Denotes an instruction regarding the risk of fire.  
Read the instruction carefully to ensure safe and correct use.



Denotes a prohibited operation.  
The operation must never be performed.



Denotes an instruction.  
This instruction must be strictly adhered to.



Denotes an instruction.  
Be sure to disconnect the plug from the outlet.



Denotes a prohibited operation.  
Never disassemble the instrument.



This symbol indicates alternating current (AC).



This symbol indicates direct current (DC).



This symbol indicates class II protection against electric shock.

### Notes on this Manual

- Copying or reproduction of all or part of the contents of this manual without the permission of KONICA MINOLTA is strictly prohibited.
- The contents of this manual are subject to change without prior notice.
- Every effort has been made in the preparation of this manual to ensure the accuracy of its contents. However, should you have any questions or find any errors, please contact your retailer or a KONICA MINOLTA-authorized service facility.
- KONICA MINOLTA will not accept any responsibility for consequences arising from the use of the instrument.

### Formal designations of application software used in this manual

(Designation in this manual) (Formal designation)

Bluetooth















Bluetooth®

### Trademarks

- The Bluetooth® mark and logo are registered trademarks of The Bluetooth SIG, Inc. and are used under license.
- The KONICA MINOLTA logo and symbol marks are registered trademarks of Konica Minolta, Inc.







# Safety Precautions







To ensure correct use of this instrument, read the following points carefully and adhere to them. After you have read this manual, keep it in a safe place where it can be referred to anytime a question arises.

	<b>WARNING</b> (Failure to adhere to the following points may result in death or serious injury.)
	Do not use the instrument in places where flammable or combustible gases (gasoline, etc.) are present. Doing so may cause a fire.
	Always use the AC adapter supplied as a standard accessory or the optional AC adapter (AC-A312F), and connect it to a 100 to 240 V ~ (50/60 Hz) AC outlet of the rated voltage and frequency. If an AC adapter other than those specified by KONICA MINOLTA is used, or if the adapter is connected to an unsupported voltage, it may result in damage to the instrument or AC adapter, fire, or electric shock.
	If the instrument will not be used for a long time, disconnect the AC adapter plug from the AC outlet. Accumulated dirt or water on the prongs of the AC adapter's plug may cause a fire. Clean off any dirt or water on the prongs of the AC adapter's plug before use.
	Firmly push the AC adapter plug completely into the outlet. Incomplete insertion may cause a fire or electric shock.
	Always hold the plug itself when disconnecting the power cable from an outlet. Pulling on the power cable may damage it and cause a fire or electric shock. Also, do not insert or disconnect the plug with wet hands. Doing so may cause an electric shock.
	Do not forcibly bend, twist, or pull the cords or cables. Also, do not scratch, or place heavy objects on the cables. Doing so may damage the cable and cause a fire or electric shock.
	Do not disassemble or modify the instrument or the AC adapter. Doing so may cause a fire or electric shock.
	Take special care not to allow liquid or metal objects to enter the instrument and the AC adapter. Doing so may cause a fire or electric shock. Should liquid or metal objects enter the instrument, turn the power OFF immediately, disconnect the AC adapter plug from the AC outlet, remove the battery, and contact the nearest KONICA MINOLTA-authorized service facility.
	Do not dispose of the battery in a fire or short-circuit, heat, or disassemble the battery. Doing so may cause the battery to rupture or leak, which could result in fire or injury.
	In the event that a battery leaks and the fluid comes into contact with the eyes, do not rub the eye. Wash it with clean water, and then immediately consult a doctor. If the leaked fluid comes into contact with skin or clothing, immediately rinse with water. In addition, stop using the instrument if the battery has leaked.
	When disposing of the battery used in this instrument, use tape or some other material to electrically insulate the contacts. Contact with other metals may cause the battery to overheat, rupture, or catch fire. Properly dispose of the battery according to local regulations, or recycle the battery.
	The instrument should not be operated if it or the AC adapter is damaged, or if smoke or odd smells occur. Doing so may cause a fire. In such situations, turn the power OFF immediately, disconnect the AC adapter plug from the AC outlet, remove the battery, and contact the nearest KONICA MINOLTA-authorized service facility.
	Do not insert or disconnect the AC adapter plug with wet hands. Doing so may cause an electric shock.

## Safety Precautions

---

	Do not touch the battery with wet hands. Doing so may result in electric shock or a malfunction.
	Use Data Processor CA-DP40 to charge the lithium-ion battery. If charging conditions or a charger different from that specified is used for charging, the battery may leak, overheat, or catch fire.
	Do not use, charge, or store the lithium-ion battery in a high-temperature environment. Doing so may cause the batteries to overheat, catch fire, or rupture.
	Do not throw or submit the lithium-ion battery to strong impacts such as from a fall from a high location. If the lithium-ion battery is deformed or if the built-in protection system is broken, an abnormal current or voltage may be applied to the battery during charging, which may cause the batteries to overheat, rupture, or catch fire.
	Do not step on the lithium-ion battery, pierce it with a nail, or hit it with a hammer. If the lithium-ion battery is deformed or if the protection system is damaged, the battery may overheat, rupture, or catch fire.
	Should an unusual odor, heat, discoloration, deformation, or other previously unnoticed abnormality occur during use, charging, or storage, remove the battery from the instrument or charger and discontinue use. Continued use of a battery in this condition may cause the batteries to overheat, rupture, or catch fire.
	If the battery is found to be leaking or emitting an unusual odor, keep the battery away from any open flames. The electrolytic solution from the battery may catch fire, causing rupture or fire.

 <b>CAUTION</b>	(Failure to adhere to the following points may result in injury or damage to the instrument or other property.)
	When using the AC adapter, make sure, that an AC outlet is located near the instrument, and that the AC adapter plug can be connected to and disconnected from the AC outlet easily.
	When cleaning the instrument, unplug the AC adapter plug from the outlet. Failure to do so may result in electric shock.
	Do not use any battery other than that specified for use with the instrument. When inserting a battery into the instrument, be sure to insert the battery correctly according to the polarity (positive +, negative -) display on the instrument. Fire, injury, or stains on surroundings may occur if the battery is damaged or leaking.
	Do not use a wet battery. Doing so may cause the battery to rupture or overheat, which could result in fire or injury.
	Do not place the instrument on an unstable or sloping surface. Doing so may result in the instrument dropping or overturning, causing injury. Be careful not to drop the instrument when carrying it as well.
	Take care not to pinch yourself on the areas of the instrument that open and close. Doing so may result in injury.

# Introduction

---

The CA-410 series is an instrument designed to measure the color, luminance, and flicker of various color displays. Please read this manual carefully before using the instrument.

## Packing materials of the product

Be sure to keep all packing materials used for shipping the instrument (cardboard box, cushioning material, plastic bags, etc.). This instrument is a precision measuring instrument. When transporting the instrument to a service facility for maintenance or for other reasons, be sure to use the packing materials to minimize shock or vibration. If the packing materials are lost or damaged, contact a KONICA MINOLTA-authorized service facility.

## Notes on Use

### Operating Environment

- This instrument and the AC adapter have been designed exclusively for indoor use. Outdoor use is prohibited.
- This instrument is composed of precision electronic components. Never disassemble the instrument.
- Always use the AC adapter supplied as a standard accessory (AC-A312F) and connect it to a 100 to 240 V $\sim$  (50/60 Hz) AC outlet. Use an AC power supply of the rated voltage (within  $\pm 10\%$ ).
- This instrument is a pollution level 2 product (equipment to be used primarily in manufacturing environments, laboratories, warehouses, and similar locations). This instrument should be used in environments where exposure to metallic dust or condensation is not a concern.
- This instrument is an overvoltage category I product (equipment for connection to circuits in which measures are taken to limit transient overvoltage to an appropriately low level).
- This instrument complies with Electrical equipment for measurement, control and laboratory use - EMC(Electromagnetic Compatibility) requirements - Part 1: General requirements (EU Harmonized Standards EN 61326-1:2021). Conformity verification is performed under KONICA MINOLTA's test conditions in an INDUSTRIAL ELECTROMAGNETIC ENVIRONMENT specified in the relevant harmonized standards. The limit of performance degradation when subjected to continuous disturbance during immunity testing is up to twice KONICA MINOLTA's repeatability specifications (Lv, x, y).
- Do not use the instrument at altitudes higher than 2,000 m.
- Take care to prevent foreign matter from entering the instrument. Using the instrument while subjected to intrusion of water or metals is extremely dangerous.
- Using the instrument in direct sunlight or near heating equipment can cause the internal temperature of the instrument to become much higher than the ambient temperature, resulting in malfunction. Do not use the instrument in such areas. Also, use the instrument in a well-ventilated environment.
- Avoid subjecting the instrument to sudden temperature changes and condensation.
- Do not use the instrument in areas where dust, smoke, or chemical gases are present, or in extremely humid environments.
- This instrument should be used in an environment with an ambient temperature between 10 and 35°C and a relative humidity of 85% or less. Use of the instrument outside this range will result in unsatisfactory performance.

### System

- Do not subject the instrument to strong vibrations or impacts.
- Do not pull, forcibly bend, or apply excessive force to the connected cables and cords. Doing so may cause the cable or cord to break.
- The instrument should be connected to a power source with as little noise as possible.
- When a malfunction or abnormal behavior occurs, turn the power OFF immediately, and disconnect the AC adapter plug from the AC outlet.
- The instrument may cause interference if used near a television, radio, transceivers, etc.
- If the instrument is exposed to strong external static electricity, the LCD may go blank or fail to display information correctly. Communication with a connected external device may also be interrupted. In such cases, turn the power OFF and then ON again. If black smudges appear on the LCD, wait until they disappear naturally.
- When turning the power OFF and then ON again, wait several seconds after turning the power OFF before turning the power ON again.
- Do not turn the power off during writing to the memory such as calibration and measurement.

## Introduction

---

- The instrument may not operate properly due to the compatibility with the equipment connected to it such as a PC. Please check whether the instrument operates properly by yourself.
- When restarting the instrument, wait several seconds after turning the power OFF before turning the power ON again.

### Power Source

- Make sure that the power is turned OFF when the instrument is not in use.
- Do not connect the AC adapter to an overloaded electrical circuit. In addition, do not cover or wrap the AC adapter with cloth or other material while in use. Doing so may cause an electric shock or fire.

### Backup Battery

- Various settings are stored in the data processor's built-in battery-powered backup memory.
- The battery takes about 20 hours to become fully charged. There is no need to worry about overcharging.
- At full charge, the backup battery can store data for up to one year. However, the backup battery may not be fully charged when the instrument is purchased. The backup battery will charge as the instrument is being used.
- Do not attempt to replace the data processor's built-in backup battery. The battery should only be replaced by KONICA MINOLTA. To replace the backup battery, please contact a KONICA MINOLTA-authorized service facility.
- Periodic backup of important data and settings to another storage medium is recommended.

### Lens

- Before measurement, make sure that the lens surface is not dirty. You may not be able to perform correct measurement if there is dirt, dust, or finger mark on it, or if stain remains after cleaning.
- Do not touch the lens surface with hands.
- Avoid subjecting the instrument to sudden temperature changes under a high-humidity environment. It may fog the lens and hinder correct measurement.

### Battery

- Use only the optional accessory lithium-ion battery CM-A223. Absolutely do not use any other type of battery.
- The battery is only slightly charged upon purchase and must therefore be charged.
- The battery takes about 5 hours to become fully charged. There is no need to worry about overcharging.
- The battery will self-discharge. The battery will become unusable due to over discharging if being left for a long period. Charge it for at least one hour using the charger supplied with a data processor at least semiannually.
- After using up the battery, do not leave it uncharged.
- Charging should be performed at between 10 and 35°C. Charging will not be performed outside this temperature range.
- Excessive increases in battery temperature may temporarily interrupt charging. In such situations, wait until the battery temperature decreases for charging to resume.
- If the lithium-ion battery will not be used for a long period, remove the battery from the instrument and store it in a location not subject to high temperatures or high humidity.

### Storing the Instrument

- This instrument should be stored at a temperature between 0 and 45°C with a relative humidity of 85% or less and no condensation. Storing the instrument in an environment with high temperatures and high humidity will result in unsatisfactory performance. Storing the instrument at or near room temperature and humidity is recommended.
- Make sure that the instrument is not subjected to condensation when stored. In addition, take care to prevent rapid temperature changes to prevent condensation from occurring when transporting the instrument to the storage location.
- Storing the instrument in direct sunlight or near heating equipment can cause the internal temperature of the instrument to become much higher than the ambient temperature, resulting in malfunction. Do not store the instrument in such areas.
- Do not store the instrument in areas where dust, smoke, or chemical gases are present. Doing so may cause deterioration in performance or a malfunction.
- Do not leave the instrument inside the cab or trunk of a vehicle. Otherwise, the temperature and/or humidity during midsummer or midwinter may exceed the allowable range for storage, resulting in a malfunction.
- Before storing, make sure that the lens is attached with the cap supplied as a standard accessory.

- 
- When not in use, store the instrument in the packing used for shipment or in the optional carrying case and keep it in a safe place.

### **Notes on Cleaning**

- If the instrument becomes dirty, wipe it with a soft, dry cloth. Never use organic solvents (such as naphtha or thinner) or other chemicals for cleaning.
- If there is dust or dirt on the optical system of a probe, use a blower to blow it off and then gently wipe it with a soft, dry cloth or with a lens-cleaning cloth. Never use organic solvents (such as naphtha or thinner) or other chemicals for cleaning.
- If you are unable to remove dirt from the instrument or if the instrument becomes scratched, contact a KONICA MINOLTA-authorized service facility.

### **Notes on Transporting**

- When transporting the instrument, be sure to use the packing materials to minimize shock or vibration.
- When sending the instrument in for service, package and send the instrument and all accessories.

### **Maintenance and Inspection**

- To maintain measurement accuracy, the instrument should be inspected once a year. For information on inspection, contact the nearest KONICA MINOLTA-authorized service facility.

### **Disposal Method**

- Make sure that the instrument, its accessories, and the packing materials are either disposed of or recycled correctly in accordance with local laws and regulations.

### **About This Manual**

This manual is designed for those who possess basic knowledge of displays and relevant equipment.

Please read this manual carefully before using the instrument.

In the descriptions about probes in this manual, probes are described as “probe” where the type of probe is not specified.

### **For Those Who Want to Purchase Optional Accessories for This Instrument**

This manual also explains how to use optional accessories available for this instrument.

If an explanation of how to use an optional accessory is given in this manual, its product name is also given.

Please read the explanation together with the manual supplied with the accessory.

# Table of Contents

---

Safety Precautions .....	1
Introduction .....	3
Configuration of the CA-410 Series .....	8
1. Configuration .....	8
2. System Diagram.....	9

<b>Probe Guide.....</b>	<b>11</b>
<b>Probes .....</b>	<b>12</b>
1. About Probes .....	12
2. Probe Lineup.....	13
3. Standard Accessories .....	13
4. Optional Accessories.....	14
5. Description of Each Part of Probes .....	15
6. How to Set a Probe .....	16
7. How to Connect Cables.....	17
<b>About Zero Calibration .....</b>	<b>19</b>
1. How to Check Zero Calibration.....	19
<b>Measurement Functions of Probes .....</b>	<b>19</b>
1. Measurement Speeds.....	19
2. Measurement Synchronization Modes .....	20
3. Measurement Modes.....	21
<b>User Memory .....</b>	<b>22</b>
1. About Calibration Channels .....	22
2. About Targets .....	22
3. About User Calibration .....	23

<b>Data processor CA-DP40 .....</b>	<b>25</b>
<b>Data Processor CA-DP40 .....</b>	<b>26</b>
1. About the Data Processor .....	26
2. Standard Accessories .....	26
3. Optional Accessories.....	27
<b>Names and Functions of Parts.....</b>	<b>28</b>
<b>Display Screen .....</b>	<b>30</b>
1. Screen configuration.....	30
2. Basic screen .....	30
<b>Operations on Each Screen .....</b>	<b>35</b>
1. Measurement screen.....	35
2. Zero calibration screen.....	36
3. Screen in remote mode.....	36
4. Changing color modes.....	37
5. Graph .....	38
6. Menu screen .....	39
<b>Manual Structure .....</b>	<b>40</b>



<b>Connection .....</b>	<b>44</b>	<b>Measurement .....</b>	<b>86</b>
<b>Connections .....</b>	<b>45</b>	<b>Measurement .....</b>	<b>87</b>
1. Connecting a Probe to the Data Processor .....	45	1. Performing Measurement .....	87
2. Attaching/Detaching a Battery.....	46	2. Holding the Measured Values .....	88
3. Connecting the AC Adapter.....	47	3. Displaying the Measured Values .....	88
4. Vertical synchronization signal input .....	47	4. Checking and Deleting Measurement Data.....	90
5. Connecting a Remote Switch .....	48		
<b>Turning the Power ON/OFF .....</b>	<b>49</b>	<b>Settings .....</b>	<b>92</b>
1. Turning the Power ON/OFF.....	49	<b>Setting the Selectable Color Spaces .....</b>	<b>93</b>
2. Instrument Status at Power-ON .....	50	<b>Selecting the Color Mode.....</b>	<b>94</b>
		<b>Selecting the Absolute Value/     Color Difference Display .....</b>	<b>95</b>
<b>Measurement Preparation.....</b>	<b>51</b>	<b>Setting the Display Brightness.....</b>	<b>96</b>
<b>Zero calibration .....</b>	<b>52</b>	<b>Setting Operation Sounds .....</b>	<b>97</b>
1. Performing Zero Calibration .....	52	<b>Auto 0-Cal Settings .....</b>	<b>98</b>
2. How to Check Zero Calibration.....	53	<b>Save Destination Setting .....</b>	<b>99</b>
<b>Setting the Sync Mode.....</b>	<b>54</b>	<b>Selecting Luminance Units .....</b>	<b>100</b>
<b>Setting the Measurement Speed.....</b>	<b>56</b>	<b>Setting the Power Save mode .....</b>	<b>101</b>
<b>Setting the Trigger Mode .....</b>	<b>57</b>	<b>Setting the Internal Clock.....</b>	<b>102</b>
<b>Setting the Interval Measurement .....</b>	<b>59</b>	<b>Setting the Date Format .....</b>	<b>103</b>
<b>Setting the Interval Alert .....</b>	<b>61</b>	<b>Selecting the Display Language.....</b>	<b>104</b>
<b>JEITA Freq Resolution Setting.....</b>	<b>63</b>	<b>Checking the Instrument Information.....</b>	<b>105</b>
<b>Selecting a Probe No. ....</b>	<b>65</b>	<b>Initializing the Settings .....</b>	<b>106</b>
<b>Calibration/Settings .....</b>	<b>66</b>	<b>Communication .....</b>	<b>107</b>
<b>Outline of the Calibration/Settings Section.....</b>	<b>67</b>	<b>RS-232C Connection .....</b>	<b>108</b>
1. Measurement using Konica Minolta's Calibration Standard .....	67	1. Connection to a PC or PLC via RS-232C .....	108
2. Measurement using user calibration .....	67	2. Setting the RS-232C Baud Rate .....	109
<b>Calibration.....</b>	<b>68</b>	<b>USB Connection .....</b>	<b>110</b>
1. About Calibration Channels .....	68	1. Connection to a PC via USB .....	110
<b>About User Calibration .....</b>	<b>69</b>	<b>Ethernet Connection .....</b>	<b>111</b>
<b>Performing User Calibration .....</b>	<b>70</b>	1. Connection to a PC via Ethernet .....	111
1. By Measurement (Single-point calibration) ....	70	2. Setting the DHCP .....	112
2. By Measurement ( RGB+W matrix calibration).....	72	<b>Bluetooth Connection .....</b>	<b>114</b>
3. By selecting from saved data .....	74	1. Connecting via a Bluetooth Module.....	114
4. By inputting correction coefficients .....	76	2. Turning Bluetooth ON.....	115
5. Setting an ID .....	78	3. PC Connection .....	116
<b>Deleting Calibration Data .....</b>	<b>80</b>		
<b>Setting/Changing the Target.....</b>	<b>82</b>	<b>Explanation .....</b>	<b>117</b>
1. Target .....	82	<b>Dimensions.....</b>	<b>118</b>
2. By Measurement and Registration .....	82	<b>Errors and Countermeasures .....</b>	<b>119</b>
3. By Entering Values .....	84	<b>Main Specifications .....</b>	<b>120</b>

# Configuration of the CA-410 Series

---

## 1. Configuration

---

The CA-410 series consists of the following three systems:

### ● Probes

Sensor units for measuring displays.

Can be connected to a PC to perform measurement (using PC software).

Can be connected to a data processor to perform measurement.

### ● Data Processor CA-DP40

Can connect up to ten probes simultaneously to perform measurement.

Can be connected to a PC so that it can be controlled from the PC (using PC software).

Note: • Advanced high-sensitivity probes CA-VP427A and CA-VP410A cannot be controlled by the data processor.

### ● PC software CA-S40

Can control a probe connected to a PC to perform measurement.

Can control a data processor connected to a PC to perform measurement.

The Probe + Data Processor Instruction Manual (this document) contains the following descriptions for probes and Data Processor CA-DP40:

- Handling procedure and specifications of probes
- How to measure when probe and data processor are connected
- How to connect the data processor to a PC

## 2. System Diagram

### [Probe]

#### Advanced High Sensitivity Probe High Sensitivity Probe

CA-VP427A  
CA-VP427

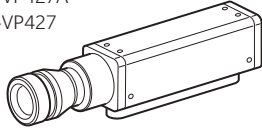

CA-VP410A

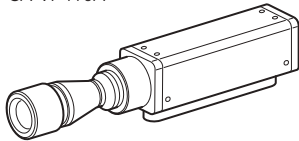

#### Normal Probe

\* CA-P427

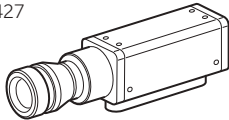

\* CA-P410

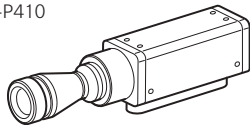

#### Other Probes

CA-P427C  
CA-VP402  
CA-VP404  
CA-VP410T

\* High-luminance models capable of measurement even at luminance levels as high as 30,000 cd/m<sup>2</sup> are also available.

\*\* Advanced high-sensitivity probes CA-VP427A and CA-VP410A cannot be controlled by the data processor.

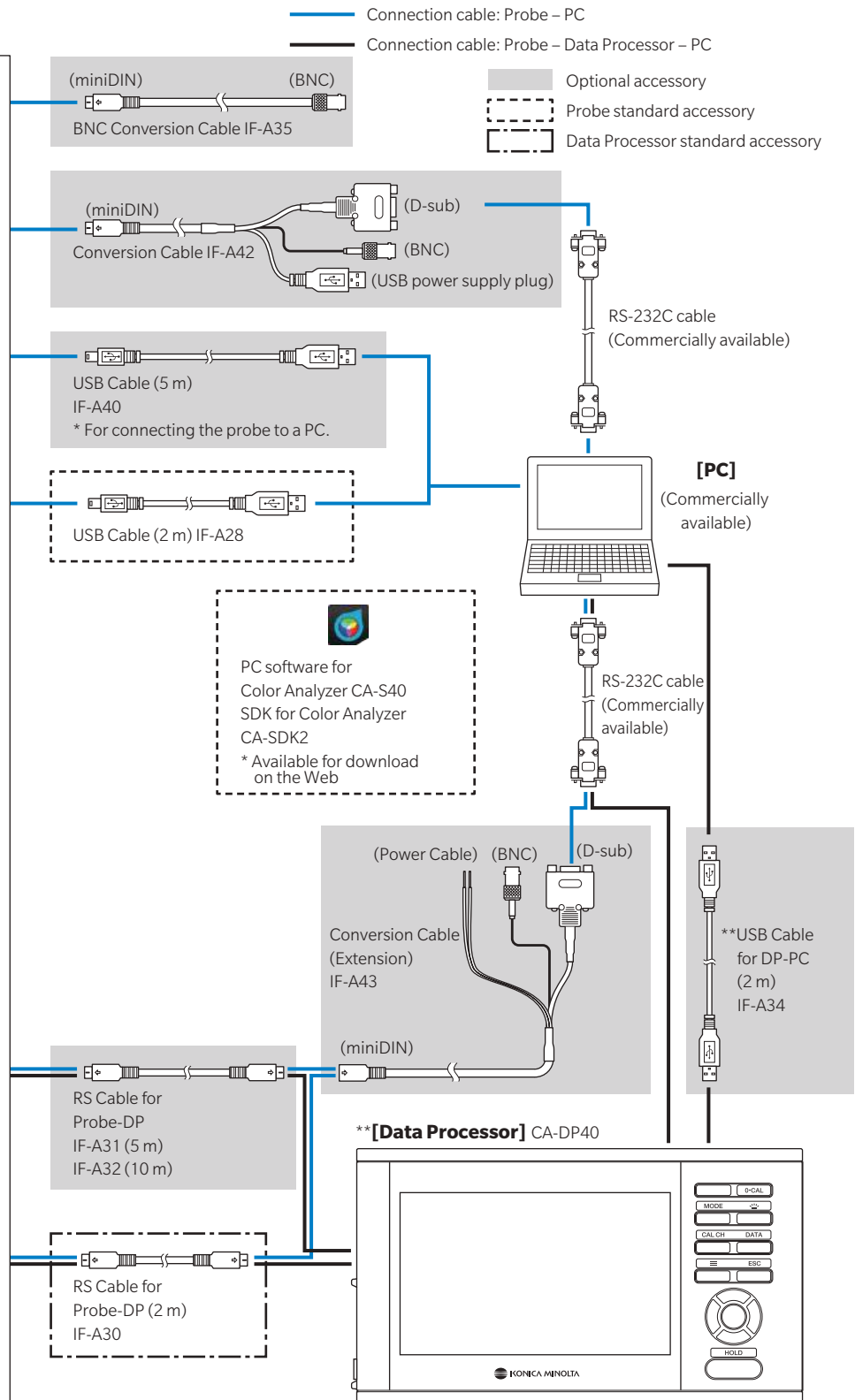

\*\*Lithium-Ion Battery  
CM-A223



\*\*AC Adapter  
AC-A312F

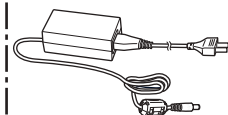

\*\*Bluetooth Module  
CM-A219



Can only be used with a Windows OS

\*\*Carrying Case  
CA-A01





# Probe Guide

<b>Probes .....</b>	<b>12</b>
<b>1. About Probes .....</b>	<b>12</b>
<b>2. Probe Lineup.....</b>	<b>13</b>
<b>3. Standard Accessories .....</b>	<b>13</b>
<b>4. Optional Accessories .....</b>	<b>14</b>
<b>5. Description of Each Part of Probes .....</b>	<b>15</b>
<b>6. How to Set a Probe .....</b>	<b>16</b>
<b>7. How to Connect Cables.....</b>	<b>17</b>
<b>About Zero Calibration .....</b>	<b>19</b>
<b>1. How to Check Zero Calibration.....</b>	<b>19</b>
<b>Measurement Functions of Probes .....</b>	<b>19</b>
<b>1. Measurement Speeds.....</b>	<b>19</b>
<b>2. Measurement Synchronization Modes .....</b>	<b>20</b>
<b>3. Measurement Modes.....</b>	<b>21</b>
<b>User Memory .....</b>	<b>22</b>
<b>1. About Calibration Channels .....</b>	<b>22</b>
<b>2. About Targets .....</b>	<b>22</b>
<b>3. About User Calibration .....</b>	<b>23</b>

# Probes

## 1. About Probes

A CA-410 series probe can be used to measure the luminance, chromaticity, and flicker values of displays.

A probe can be controlled in the following three ways:

- You can connect a probe to a PC and control it from PC software to perform measurement. By using the standard software, PC Software CA-S40 For Color Analyzers, you can select one of the probes connected to a PC via USB and control it to perform measurement.

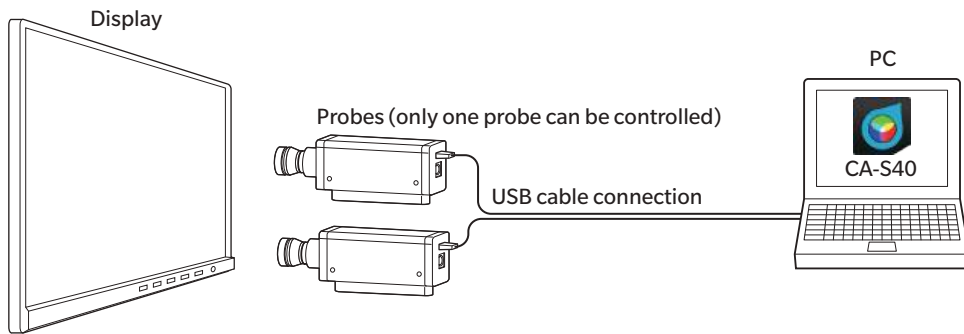

- You can connect a probe to a data processor and control it from the data processor to perform measurement. Multiple probes can be controlled simultaneously to perform measurement.

Note: • Advanced high-sensitivity probes CA-VP427A and CA-VP410A cannot be controlled by the data processor.

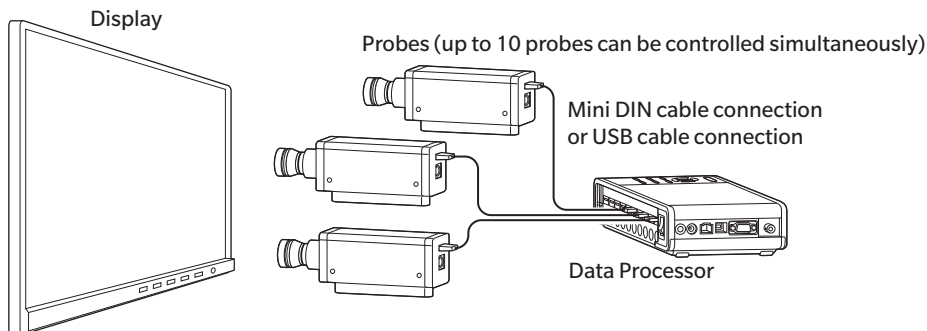

- You can connect a probe to a data processor, connect the data processor to a PC, and control it from PC software to perform measurement. By using the standard software, PC Software for Color Analyzer CA-S40, you can select one of the probes connected to the data processor and control it to perform measurement.

Note: • Advanced high-sensitivity probes CA-VP427A and CA-VP410A cannot be controlled by the data processor.

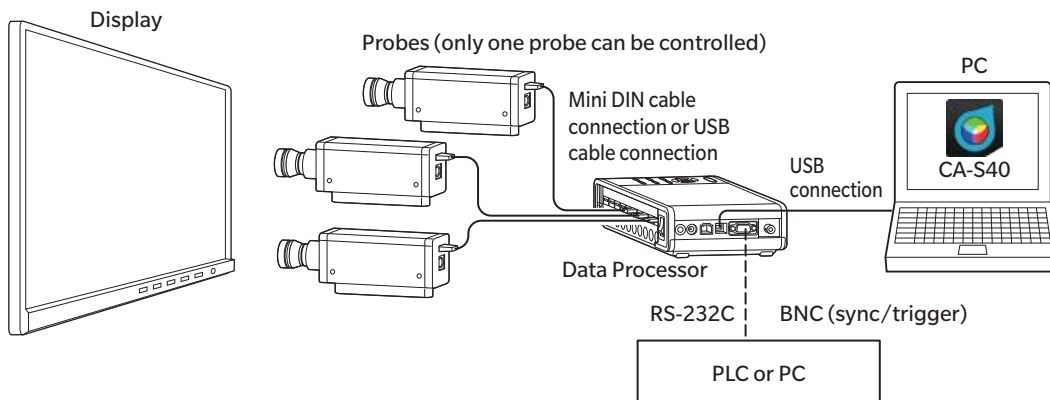

## 2. Probe Lineup (All Probes are Provided with Lens Caps)

The following probes are available according to the application.

Model	Name	Description
CA-P427	ø27 Probe	Probe with a measurement area of 27 mm
CA-P427H	ø27 Probe for high luminance	High-luminance probe with a measurement area of 27 mm
CA-P410	ø10 Probe	Probe with a measurement area of 10 mm
CA-P410H	ø10 Probe for high luminance	High-luminance probe with a measurement area of 10 mm
CA-MP410H	ø10 mini Probe for high luminance	Compact high-luminance probe with a measurement area of 10 mm
CA-VP427	ø27 High Sensitivity Probe	High-sensitivity probe with a measurement area of 27 mm
CA-VP427A	ø27 Advanced High Sensitivity Probe	Advanced high-sensitivity probe with a measurement area of 27 mm
CA-VP410A	ø10 Advanced High Sensitivity Probe	Advanced high-sensitivity probe with a measurement area of 10 mm
CA-P427C	ø27 Probe (CIE 170-2:2015 compliant)	CIE 170-2:2015-compliant probe with a measurement area of 27 mm
CA-VP402	ø2 Small Spot Probe	Probe with a measurement area of 2 mm
CA-VP404	ø4 Small Spot Probe	Probe with a measurement area of 4 mm
CA-VP410T	ø10 LWD Probe (200 mm)	Probe with a measurement area of 10 mm and a measurement distance of 200 mm

- Note:
- High-sensitivity probe CA-VP427, advanced high-sensitivity probes CA-VP427A and CA-VP410A, small spot probes CA-VP402 and CA-VP404, and LWD probe CA-VP410T cannot measure flicker in CA-310 Mode.
  - Advanced high-sensitivity probes CA-VP427A and CA-VP410A cannot be controlled by the data processor.
  - Use of a high-luminance probe is recommended for measuring a display that instantaneously shows high luminance, such as CRTs.
  - The CA-VP402 probe is designed for measurement of displays with a high pixel density, such as micro OLED displays. The pixels within the measurement area may be insufficient when measuring smartphone displays or other displays, and measured values may be unreliable due to the influence of position reproducibility.

## 3. Standard Accessories

### ● Hoods and lens caps

Use	Hood		Lens cap	
	Model	Name	Model	Name
For a ø27 probe	CA-H12	Hood for ø27 Probe	CA-H13	Lens Cap for ø27 Probe
For a ø10 probe	CA-H14	Hood for ø10 Probe	CA-H15	Lens Cap for ø10 Probe
For a ø10 mini probe	CA-H16	Hood for ø10 Mini Probe	CA-H17	Lens Cap for ø10 Mini Probe
For a ø27 high-sensitivity probe and ø27 advanced high-sensitivity probe	CA-H18	Hood for ø27 High Sensitivity Probe	CA-H19	Lens Cap
For a ø10 high-sensitivity probe and ø10 advanced high-sensitivity probe	CA-H20	Hood for ø10 High Sensitivity Probe	CA-H21	Lens Cap
For a ø2 Small Spot Probe	CA-H22	Hood for ø2 Small Spot Probe	CA-H19	Lens Cap
For a ø4 Small Spot Probe	CA-H23	Hood for ø4 Small Spot Probe	CA-H21	Lens Cap
For a ø10 LWD Probe	—	—	CA-H21	Lens Cap

## Probes

### ● USB Cable (2 m) IF-A28

Connects a probe to a data processor or a PC via USB.  
How to connect: Refer to page 17.

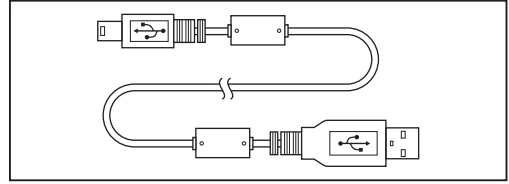

### ● PC Software for Color Analyzer CA-S40

Controls a probe or data processor connected to a PC via USB to perform measurement.  
For how to use it, refer to the instruction manual for the PC software.



### ● SDK for Color Analyzer CA-SDK2

A library for users to create programs on their own.

### ● Instruction Manual (this manual)

Please read before using the instrument.

\* The latest version of PC Software CA-S40 and SDK CA-SDK2 are available for download from the following product support webpage: <https://www.konicaminolta.com/instruments/download/>

## 4. Optional Accessories

### ● Conversion Cable IF-A42

Connects a probe to a PC or PLC (sequencer) via RS-232C and inputs synchronization signals to the probe.  
How to connect: Refer to page 17.

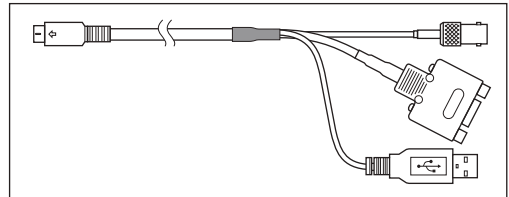

### ● Conversion Cable (Extension) IF-A43

Connects to a probe via a Probe-DP RS Cable IF-A30/A31/A32 for longer distance connections. Connects to a PC or PLC (sequencer) via RS-232C and inputs synchronization signals to the probe.  
How to connect: Refer to page 17.

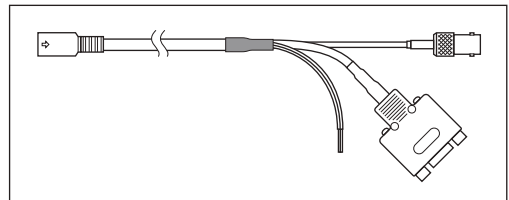

### ● BNC Conversion Cable IF-A35

Inputs synchronization signals to the probe.  
How to connect: Refer to page 18.

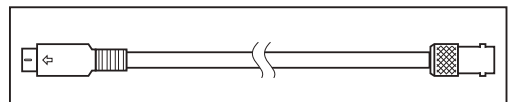

### ● USB Cable (5 m) IF-A40

For connecting the probe to a PC.  
How to connect: Refer to page 17.

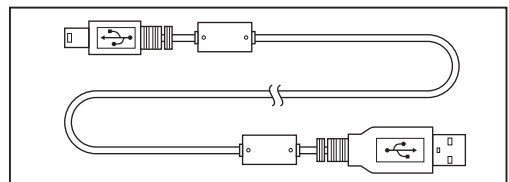



## 5. Description of Each Part of Probes

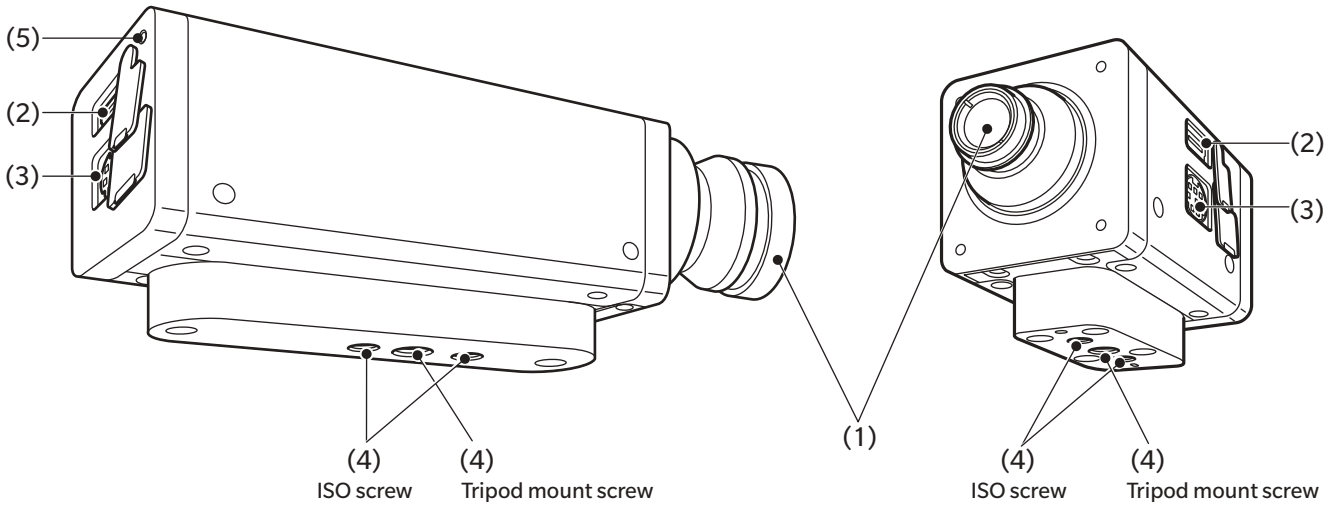

### ● Probe other than mini

Note: CA-P427, P427H, P410, and P410H have another tripod mount screw on the front side of the ISO screw. For details, refer to the dimensions.

### ● Mini probe

Note: Mini probes have screws for jigs and cable clamps. For details, refer to the dimensions.

#### (1) Receptor

Make this part face perpendicular to a display to perform measurement.

#### (2) USB connector

For USB connection with a data processor or a PC, connect the USB cable IF-A28 supplied as a standard accessory.

#### (3) RS-232C connector

For RS-232C connection to a data processor, connect the mini DIN cable IF-A30/31/32 for the data processor to the RS-232C connector.

Note: • Advanced high-sensitivity probes CA-VP427A and CA-VP410A cannot be controlled by the data processor.

For RS-232C connection with a PLC or PC, connect an optional conversion cable IF-A42.

Use a conversion cable IF-A42/43 or a BNC conversion cable IF-A35 to input the display's vertical synchronization signals, which are used for measurement in "EXT" measurement synchronization mode.

#### (4) Screw holes

There are two types of screws for securing a probe:

Tripod mount screw: Used for mounting the probe on a tripod. The depth is 6 mm.

ISO screw: Used for securing the probe to jigs. Use an ISO 5 mm screw and the depth is 6 mm.

- The distance from each screw to the end of the optical column is the same as that for a CA-310 series probe. (Excluding mini probes, the CA-VP402, the CA-VP404, and the CA-VP410T.)
- The position of the optical axis (in the height direction) is the same as that for a CA-310 series probe.

#### (5) Status indicator

Located on the rear of all probes to indicate the status of the probe.

No power supply: Off

During measurement or zero calibration: Off

Memory error: Blinking (On for 0.2 sec, then Off for 0.2 sec)

Zero calibration not performed: Blinking (On for 1 sec, then Off for 0.2 sec)

Measurement possible: On (even when measurement is not possible due to the setting of an invalid synchronization frequency or integration time in INT, EXT, or MANUAL sync mode, without displaying that state)

## 6. How to Set a Probe

### 1 Secure the display.

### 2 Secure the probe in a way to place its end 30 mm \*1 away from the display surface.

Be sure to set it perpendicular to the display.

\*1: L = 10 mm for mini probes.

L = 28 mm for the CA-VP402.

L = 200 mm for the CA-VP410T.

\*2: No hood is used for the CA-VP410T.

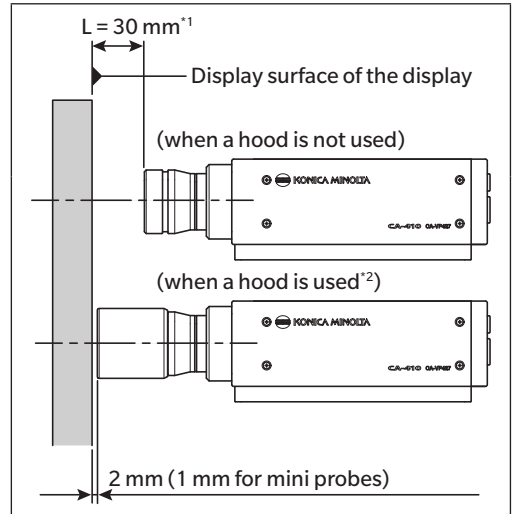

### Notes on setting

- When measuring displays with high view angle dependence, you can obtain a higher measurement reproducibility by not changing the setting angle  $\theta$  for every measurement. In particular, the CA-VP410A advanced high-sensitivity probe, and the CA-VP402 and CA-VP404 small spot probes have a large aperture angle, which has a greater effect on the viewing angle. When measuring displays with a high view angle dependence, run user calibration and use the probe without rotating it from the calibrated position.
- Use of the hood supplied as a standard accessory not only blocks ambient light but also makes it easier to achieve a proper measurement distance and an angle of  $90^\circ$ .
  - The guaranteed-accuracy measurement distance for a  $\phi 27$  probe is  $L = 30 \text{ mm} \pm 10 \text{ mm}$ .
  - The guaranteed-accuracy measurement distance for a  $\phi 10$  probe is  $L = 30 \text{ mm} \pm 5 \text{ mm}$ .
  - The guaranteed-accuracy measurement distance for a mini probe is  $L = 10 \text{ mm} \pm 5 \text{ mm}$ .
  - The guaranteed-accuracy measurement distance for the CA-VP402 is  $L = 28 \text{ mm} \pm 2 \text{ mm}$ .
  - The guaranteed-accuracy measurement distance for the CA-VP404 is  $L = 30 \text{ mm} \pm 2 \text{ mm}$ .
  - The guaranteed-accuracy measurement distance for the CA-VP410T is  $L = 200 \text{ mm} \pm 2 \text{ mm}$ .
- When strict low-luminance measurement is required, perform measurement in a dark room with no external light. Even when measuring in a dark room, the ambient light from the display itself may act as an external light. In such situations, light shielding using a hood is recommended. If strict limitations are required, compare measurement results from a general luminance meter such as the CS-2000 or CS-3000, and verify whether using a hood has any effect.

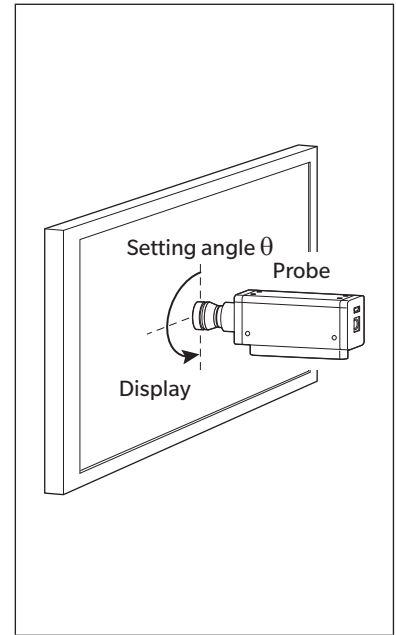

### [Relationship between specification table measurement area and guaranteed-accuracy measurement distance]

The "measurement area" indicated in the specification table is a value that satisfies the design value at the nominal guaranteed-accuracy measurement distance.

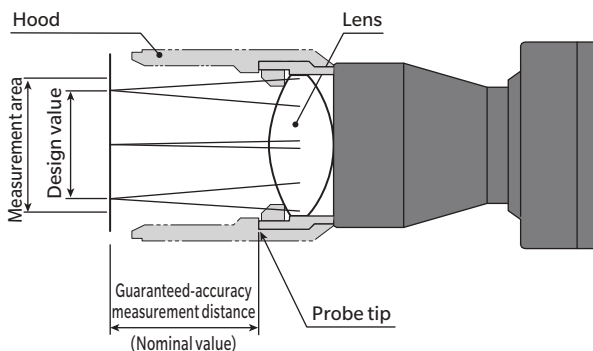

#### Probe with a measurement area of $\phi 27$

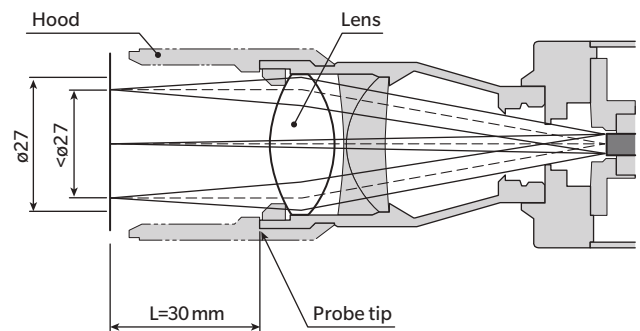

## 7. How to Connect Cables

A probe has a USB connector for connecting a USB mini B plug and a connector for connecting an RS-232C mini DIN plug. Before connection, make sure that power is not supplied to the probe and the external device. Be sure to connect a cable plug to the specified connector. Be careful not to apply load to the cable connector during wiring. Fixing the cable with a steady load on the connector may result in a communication failure.

### USB connection to PC

- Connect the USB mini B plug of the supplied USB cable IF-A28 to the USB connector of the probe. Connect the USB plug on the other side of the cable to the USB connector of the PC.

#### ●Using IF-A28

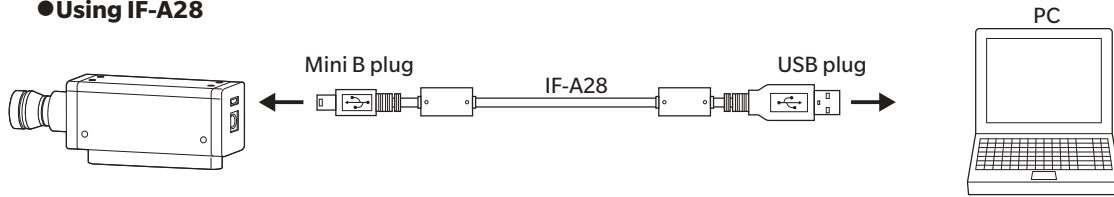

### RS-232C connection to PC or PLC

- Connect the mini DIN plug of an optional conversion cable IF-A42 to the RS-232C connector of the probe, and the D-sub plug to the RS-232C connector of the PC or PLC via a cross cable.

#### ●Using IF-A42

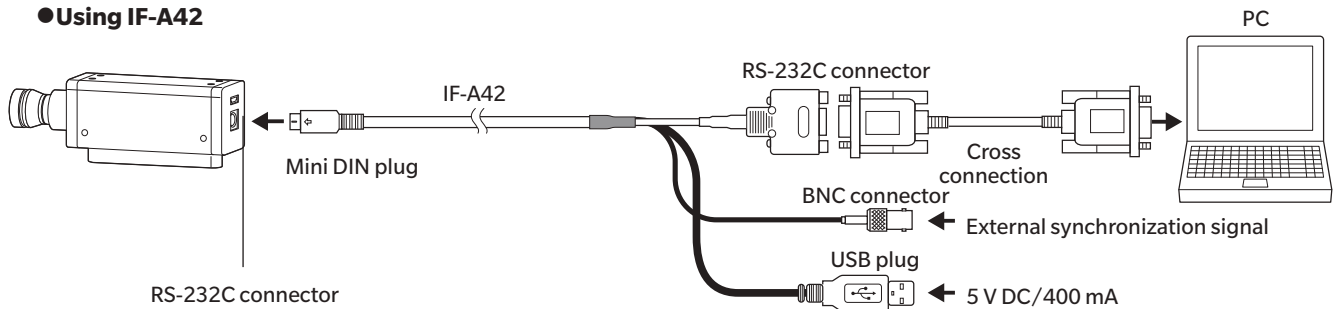

- Connect the mini DIN plug of the IF-A30 cable included with the data processor or an optional IF-A31/A32 cable to the RS-232C connector of the probe. Connect the mini DIN jack of an optional conversion cable IF-A43 to the IF-A30/A31/A32, and the D-sub plug to the RS-232C connector of the PC or PLC via a cross cable.

#### ●Using IF-A43

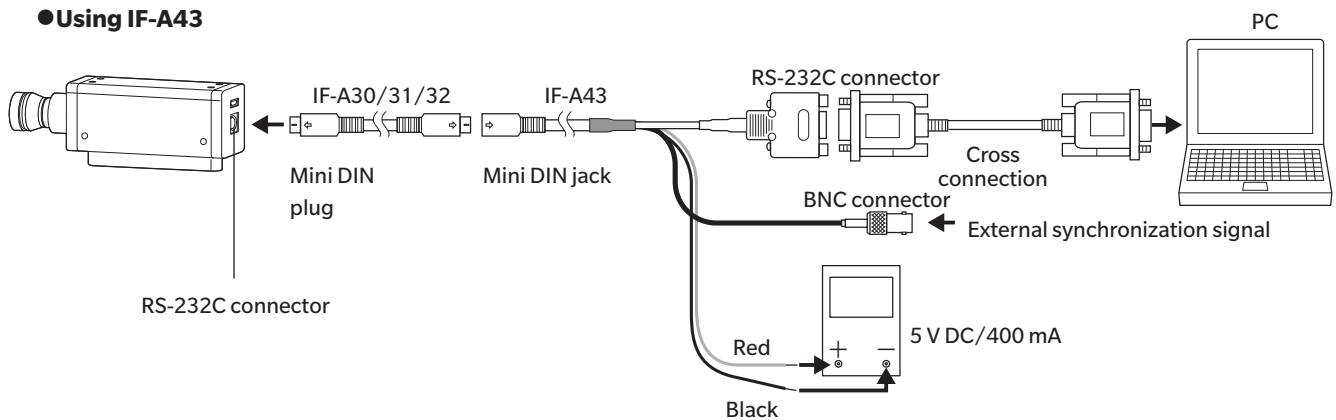

- The baud rate of the probe is set to 38,400 bps. Power must be supplied from the USB plug when using an optional conversion cable IF-A42, or from the power cable when using an optional conversion cable IF-A43. To control a probe from a PC via RS-232C, use the supplied SDK (CA-SDK2). For the specifications of the SDK and how to use it, refer to the instruction manual for CA-SDK2.

# Probes

## RS-232C connector pin No. and functions

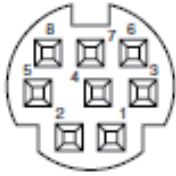

Mini-DIN 8-pin (female)

Pin No.	Pin function	Details
1	ExSync or Trigger IN	3.3 V CMOS input level (input up to 5 V) or 1.8 V CMOS input level (selectable)*, Max. 240 Hz
2	Trigger OUT	5 V CMOS output level
3	External power supply (5 V)	Min. 4.9 V to Max. 5.5 V
4	TxD	
5	GND	
6	RTS	
7	RxD	
8	CTS	

\* The 1.8 V CMOS input level can be set for probes with a serial number for which the fourth digit from the left is 2 or higher (XXX2XXXX).

## Inputting trigger and external synchronization signals to the probe

Trigger timing diagram

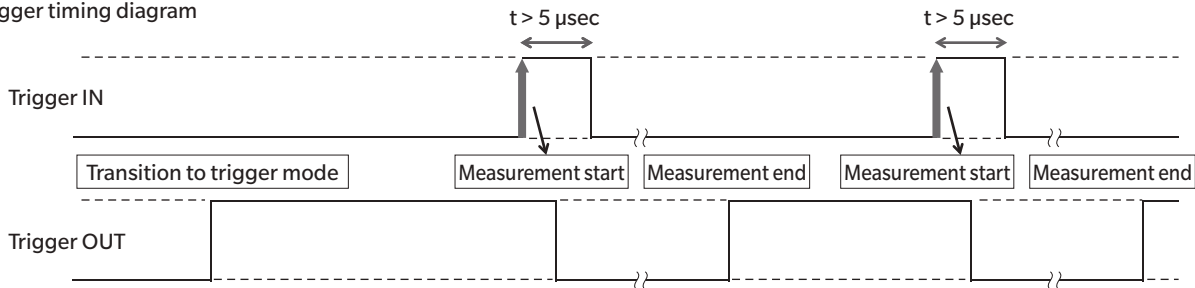

- Input the signals to the BNC plug of an optional conversion cable IF-A42/A43 or an optional BNC conversion cable IF-A35.

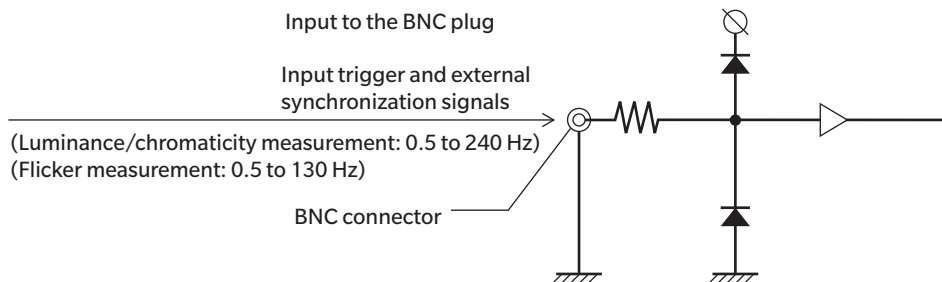

## Connecting to a CA-DP40 data processor

Connect using a mini DIN cable or a USB cable.

- For RS-232C connection, connect the mini DIN plug of the RS mini DIN cable IF-A30 (or IF-A31 or IF-A32) for the data processor to the RS-232C connector of the probe and the probe RS-232C connector of the CA-DP40 data processor.

### ● Connection via a mini DIN cable (using IF-A30/31/32)

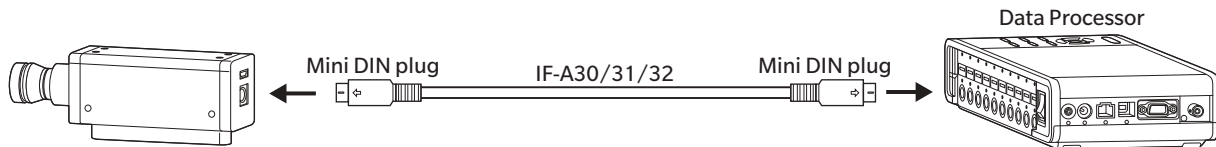

- For USB connection, connect the USB mini B plug of the supplied USB cable IF-A28 to the USB connector of the probe. Connect the USB plug on the other side of the cable to the probe USB connector of the CA-DP40 data processor.

### ● Connection via a USB cable (using IF-A28)

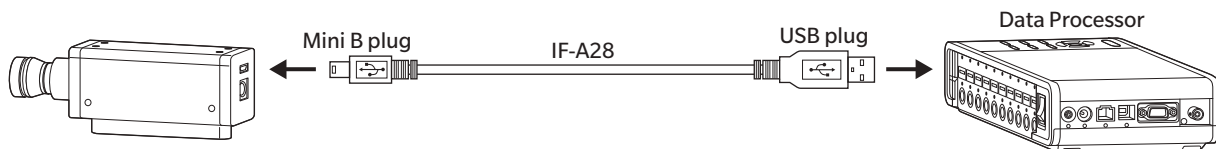

Note: • Advanced high-sensitivity probes CA-VP427A and CA-VP410A cannot be controlled by the data processor.

# About Zero Calibration

---

Zero calibration performs zero point adjustment while blocking entry of light into the probe's receptor. Be sure to perform zero calibration whenever the instrument is started.

## Notes on zero calibration

- Perform zero calibration if the ambient temperature has changed.
- Do not direct the end of the probe toward an illuminant with high luminance during zero calibration.
- Zero calibration takes longer with the CA-VP427A, CA-VP410A or CA-VP402 than other probes.

## 1. How to Check Zero Calibration

---

To check whether zero calibration has been performed correctly, block entry of light into the end of the probe using a blackout curtain, etc. so that the receptor is not exposed to light.

- Zero calibration has been performed correctly if zero is displayed for the Lv section on the controller's measured value display. If a value other than zero is displayed, perform zero calibration again.

# Measurement Functions of Probes

---

## 1. Measurement Speeds

---

A probe has the following four modes (measurement speeds), which are available according to the purpose. A probe outputs every measured value and a PC or data processor connected to it can retrieve all of them through communication. Generally, however, not all measured values are displayed but values are displayed at an appropriate interval.

### FAST mode

Requires short measurement time, but may compromise measurement repeatability for low-luminance measurements.

### SLOW mode

Repeats FAST mode measurements several times. Use this mode when you want to perform measurement with high repeatability.

### AUTO mode

Switches FAST, SLOW, and setting with a further longer integration time automatically depending on the luminance level. Normally, this is the recommended setting.

### LTD.AUTO mode

Switches between FAST and SLOW settings automatically depending on the luminance level.

## Notes on selecting the measurement speed

- The currently selected measurement speed setting is stored in the probe. The set measurement speed will be used at the next start-up.

## 2. Measurement Synchronization Modes

Measurement synchronization modes are designed to select an integration time according to the vertical scanning frequency of a display. The time required for one measurement depends on the measurement speed setting, and is an integer multiple of the integration time plus the time required for communication, calculation, etc. Select a mode suitable for the type of the display to be measured.

Measurement synchronization mode	Description of mode	Integration time (Double-Frame)	Vertical scanning frequency	Display's vertical synchronization signal input
NTSC	Mode for measuring NTSC displays	33.3 ms	59.94 Hz	Not required
PAL	Mode for measuring PAL and SECAM displays	40.0 ms	50 Hz	Not required
EXT	Mode for measuring while synchronizing with the display's vertical synchronization signal input (refer to page 18 for how to input vertical synchronization signals)	(1 vertical scanning period) ×2	0.50 to 240.00 Hz (For FMA: 0.50 to 130.00 Hz)	Required
UNIV	Mode that allows measurement with an integration time of 100 ms Available when the display's vertical scanning frequency is unknown or when input of the vertical synchronization signal is not possible. (When the light source fluctuates sharply due to PWM control, etc., fluctuations in the measured values may increase.)	100 ms	—	Not required
INT	When the display's vertical synchronization signal is known, set that information so that it can be used for measurement.	(Set vertical scanning period) ×2	Settable range 0.50 to 240.00 Hz (For FMA: 0.50 to 130.00 Hz)	Not required
MANUAL	Mode that allows you to specify the integration time	Settable range 4.0 to 4000.0 ms (For FMA: 7.7 to 4000.0 ms)	—	Not required

- Memo** /
- On a flickering LCD, the screen is fluctuating at half the frequency of the vertical scanning frequency. When you measure a display in this state, the luminance and the chromaticity vary if you set the same integration time as the vertical scanning frequency.  
When measuring with the measurement synchronization mode set to MANUAL, set the integration time double (or another even multiple of) the vertical scanning frequency to ensure stable LCD measurement.
  - The integration time can also be set to Single-Frame (half the integration time with Double-Frame) when the measurement mode is NTSC, PAL, EXT, or INT.  
Note: Integration time is fixed to Double-Frame when using a data processor.

## Relationship between measurement speed and measurement synchronization mode

The measurement time (integration time) is determined by the selected measurement synchronization mode.

Also, the measurement speed (number of measurements/outputs possible per second) is determined by the measurement synchronization mode and the following conditions:

- Luminance of the display to be measured
- Measurement mode
- Data output method (RS-232C or USB)
- Baud rate (for RS-232C)
- Number of probe to be used

Typical measurement speeds are described in the specifications.

## 3. Measurement Modes

A probe has the following measurement modes:

Measurement mode	Description of mode
xyLv mode	Mode for displaying and outputting chromaticity coordinates x, y and luminance Lv
TduvLv mode	Mode for displaying and outputting correlated color temperature T, color difference from blackbody locus duv, and luminance Lv
u'v'Lv mode	Mode for displaying and outputting u'v' chromaticity diagram coordinates (CIE 1976 UCS chromaticity diagram) and luminance Lv
Flicker mode	Displays the flicker amount in the contrast method (AC/DC). The unit is “%”.
	Displays the flicker amount in the JEITA/VESA method. The unit is “dB”.
XYZ mode	Mode for displaying and outputting tristimulus values XYZ
$\lambda$ dPeLv mode	Mode for displaying and outputting dominant wavelength $\lambda$ d, excitation purity Pe, and luminance Lv

\* Under the initial settings, the mode is set to xyLv mode at the start-up.

# User Memory

---

## 1. About Calibration Channels

---

A probe has calibration channels from CH00 to CH99 (100 channels in total).

The following can be set for each of CH00 to CH99:

- (1) Correction coefficient for user calibration
- (2) Target
- (3) ID

CH00 is a channel for calibration in accordance with the Konica Minolta calibration standard. It can only be used for setting targets or IDs.

Users can use CH01 to CH99 for calibration or saving targets.

Under the initial settings, CH01 to CH99 are also provided with the same Konica Minolta calibration value as with CH00.

Each channel can also be assigned with an ID.

### How the memory is used during user calibration

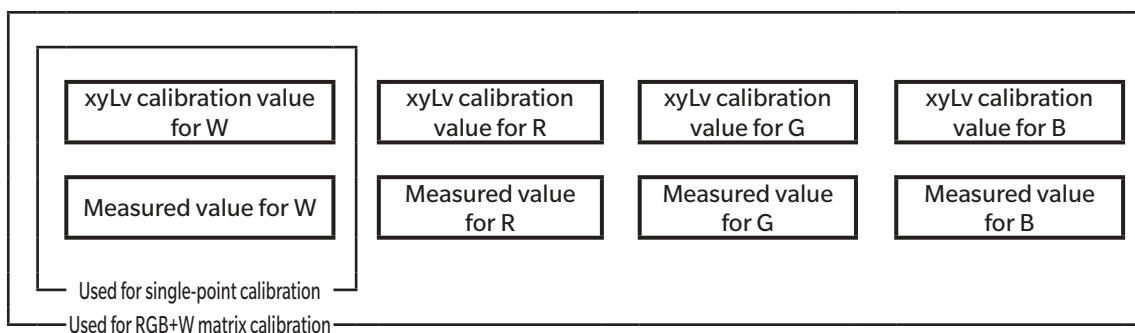

## 2. About Targets

---

Targets become the base color for measuring how different another measurable color is, which is required for color difference display. Targets can be set for each probe of each calibration channel.

Targets are set after the following operations:

- (1) User calibration: After user calibration, the calibration value is set as a target at the same time.
  - (2) Setting/changing a target: To be performed in the following cases:
    - To set a target in calibration channel CH00
    - To set a different color from user calibration as a target in a user-calibrated calibration channel
    - To perform measurement without performing user calibration but in accordance with the Konica Minolta calibration standard and to use color difference display
- If a correction coefficient for user calibration is input, a target is set at the same time, which erases the previously set target.
  - To change a set target, set/change a target. Changing a target does not change the correction coefficient set for user calibration.

In a same calibration channel, the target is saved to common channel, irrespective of measurement mode.

As a result, the target set last is saved, irrespective of measurement mode.

For one calibration channel and one probe number:

- The correction coefficient for user calibration is common to xyLv mode, TduvLv mode, u'v'Lv mode, and XYZ mode.
- The target is common to all measurement modes.



---

## 3. About User Calibration

---

- User calibration allows users to set their own correction coefficients to the calibration channel of the probe by measuring any display colors and setting calibration values (x, y, Lv) to the instrument.  
Afterward, the value corrected with the specified correction coefficients will be displayed/output for every measurement.
- Two types of user calibration can be performed for a CA-410 series probe: single-point calibration and RGB+W matrix calibration.
- RGB+W matrix calibration has been performed when the instrument is shipped from the factory.
- User calibration is performed independently for each probe.
- User calibration can be performed for every calibration channel (except for CH00).
- When a probe is used for the first time after being shipped from the factory, measurement is performed in accordance with the Konica Minolta calibration standard in all calibration channel. You can use user calibration to apply the following corrections to measurements based on the specified correction coefficients.
  - (1) Corrects the difference in the reading due to the deviation of spectral response from the CIE 1931 color-matching function.
  - (2) Corrects the difference in the readings between probes when multiple probes are used for measurement.
- When user calibration is performed, the color is set to the same calibration channel as its target at the same time.  
Targets become the base color for displaying how different another measurable color is, which is used as the base for color difference display.

### When multiple probes are used

When using multiple probes for measurement, you can correct the difference in the readings by performing user calibration as follows:

### When the target color value for the display to be measured is known

Make a standardized color display on a standard display and perform user calibration for all probes.

### When the target color value for the display to be measured is not known

- (1) Determine one master probe.
- (2) Set the measurement mode to xyLv mode, make the master probe face perpendicular to the display on which the target color is displayed, and perform measurement.
- (3) Record the measured value.
- (4) Using the display on which the target color is displayed and the value displayed in (3), perform user calibration for other probes.



# Data processor

# CA-DP40

<b>Data Processor CA-DP40 .....</b>	<b>26</b>
1. About the Data Processor .....	26
2. Standard Accessories .....	26
3. Optional Accessories .....	27
<b>Names and Functions of Parts .....</b>	<b>28</b>
<b>Display Screen .....</b>	<b>30</b>
1. Screen configuration .....	30
2. Basic screen .....	30
<b>Operations on Each Screen .....</b>	<b>35</b>
1. Measurement screen .....	35
2. Zero calibration screen .....	36
3. Screen in remote mode .....	36
4. Changing color modes .....	37
5. Graph .....	38
6. Menu screen .....	39
<b>Manual Structure .....</b>	<b>40</b>
<b>Connection .....</b>	<b>44</b>
<b>Measurement Preparation .....</b>	<b>51</b>
<b>Calibration/Settings .....</b>	<b>66</b>
<b>Measurement .....</b>	<b>86</b>
<b>Settings .....</b>	<b>92</b>
<b>Communication .....</b>	<b>107</b>
<b>Explanation .....</b>	<b>117</b>

Note: • Advanced high-sensitivity probes CA-VP427A and CA-VP410A cannot be controlled by the data processor.

# Data Processor CA-DP40

## 1. About the Data Processor

This data processor is designed to control probes that measure the luminance, chromaticity, and flicker of displays. The processor supports connection to multiple probes (up to 10) to perform measurement simultaneously. The processor can also be connected to a PC and controlled using PC software.



## 2. Standard Accessories

### ● AC adapter AC-A312F (ATS036T-A120)

Supplies power through connection to an AC outlet via an AC cable.  
Input: 100 to 240 V $\sim$ 50 to 60 Hz, Max. 1 A  
Output: 12 V $\text{---}$ 3 A  
Plug design  $\ominus$   $\oplus$  Center-positive  
How to connect: Refer to page 47.

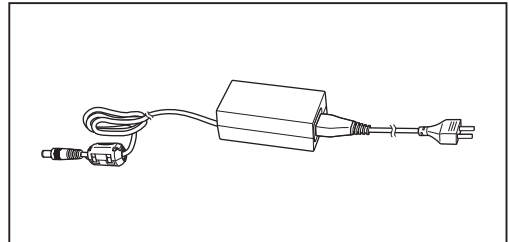

### ● AC cable

Used to connect the AC adapter to an AC outlet.

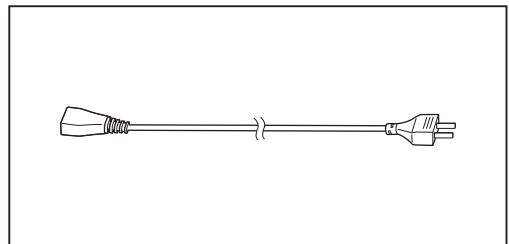

### ● Probe-DP RS cable (2 m) IF-A30

Connects the data processor to a probe via RS-232C.  
How to connect: Refer to page 45.

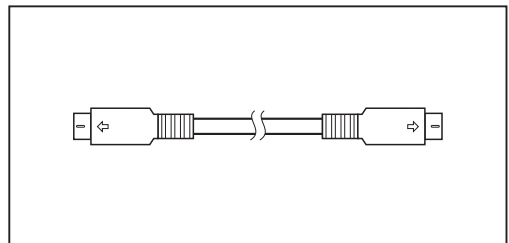

### 3. Optional Accessories

● **USB cable for DP-PC IF-A34**

Connects the data processor to a PC via USB.  
How to connect: Refer to page 110.

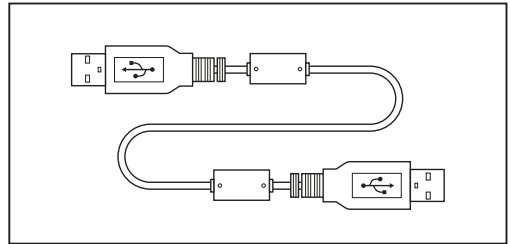

● **Lithium-ion battery CM-A223**

Drives the data processor.  
How to connect: Refer to page 46.

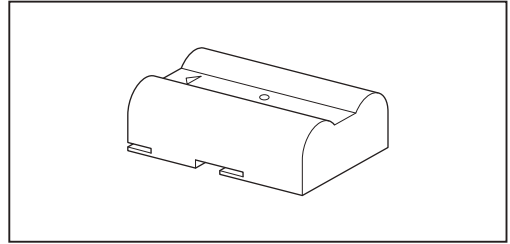

● **Bluetooth module CM-A219**

Wirelessly connects the data processor to a PC.  
How to connect: Refer to page 114.

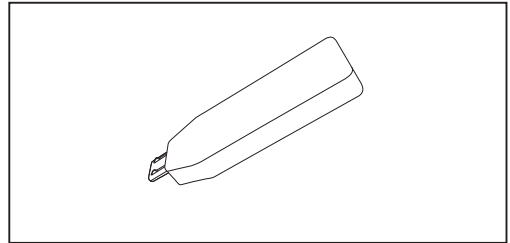

● **Probe-DP RS cable (2 m, 5 m, 10 m) IF-A30, 31, 32**

Connects the data processor to a probe via RS-232C.  
How to connect: Refer to pages 17 and 45.

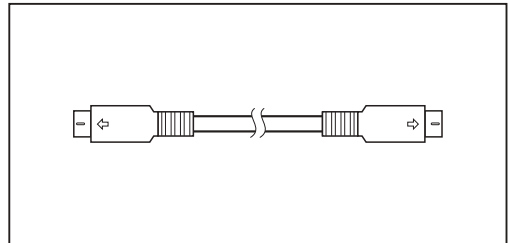

● **Carrying case CA-A01**

Designed for carrying the data processor and its accessories.



# Names and Functions of Parts

## <Front>

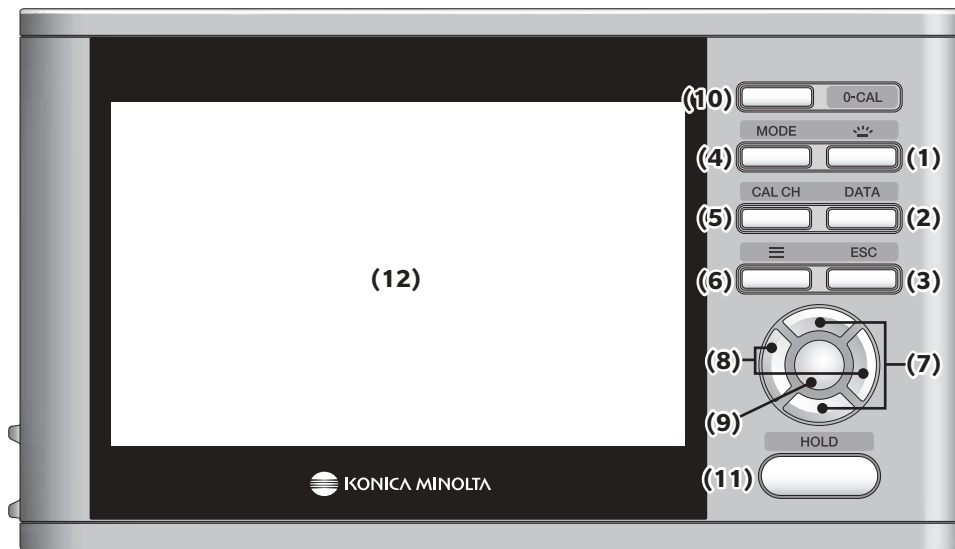

- (1) [BACKLIGHT] key..... Switches the backlight of the LCD display ON/OFF.
- (2) [DATA] key..... On the measurement screen, press this key to switch to the data screen for checking or deleting measurement results and logs. (Refer to page 90 “4. Checking and Deleting Measurement Data” in the Measurement section.)
- (3) [ESC] key..... On the menu, setting, or setting check screen, press this key to return to the measurement screen. Pressing this key while configuring the settings returns the display to the previous screen. Pressing this key while entering a value cancels the current entry. Press and hold for 2 seconds or more to lock the keys. Press and hold again to release the key lock. All key operations other than the [ESC] key, [0-Cal] key, [BACKLIGHT] key, and power switch are disabled while the keys are locked.
- (4) [MODE] key..... On the measurement screen, press this key to switch color modes. (Refer to page 37 “4. Changing Color Modes” in “Operations on Each Screen”.) (Lv,x,y -> Lv,u',v' -> Lv,Tcp,duv -> X,Y,Z -> Lv,λd,Pe -> FMA -> JEITA -> Lv,x,y)
- (5) [CAL CH] key ..... On the measurement screen, press this key to display the screen for selecting a calibration channel. (Refer to page 87 “1. Performing Measurement” in the Measurement section.)
- (6) [MENU] key ..... Toggles the screen between the measurement and setting screens.
- (7) [UP/DOWN] keys ..... Moves to the upper/lower items or increases/decreases the setting value.
- (8) [LEFT/RIGHT] keys ..... Switches to the left/right tab or moves to the left/right item.
- (9) [ENTER] key ..... Pressing this key when a menu item is selected displays the screen for setting the item. Pressing this key during value input or setting confirms the current entry.
- (10) [0-Cal] key..... Performs zero calibration.
- (11) [HOLD] key..... Switches between hold and measurement modes every time the key is pressed. (Refer to page 88 “2. Holding the Measured Values” in the Measurement section.)
- (12) Display screen ..... Displays information such as measurement results and settings.

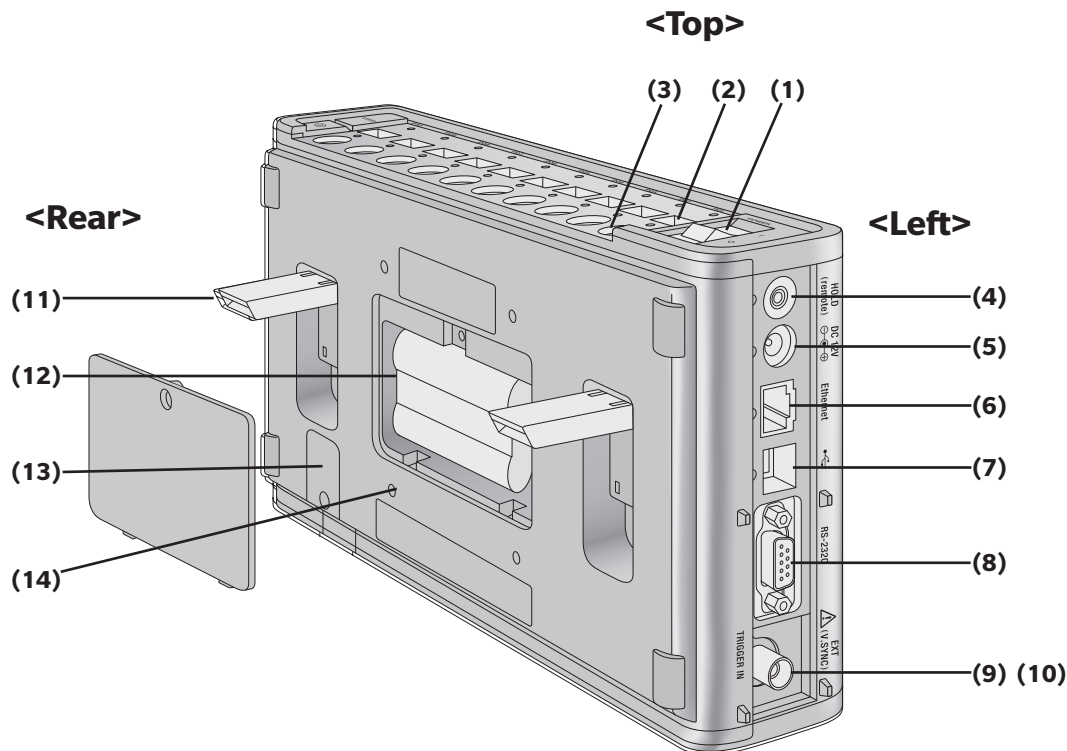

### <Top>

- (1) POWER switch..... Turns ON and OFF the power to the instrument. (P. 49)
- (2) Probe USB connectors ..... Used to connect probes using USB cables.  
Up to 10 probes can be connected simultaneously.  
Keep caps on probe connectors not in use.  
The numbers correspond to the probe numbers to be controlled.
- (3) Probe RS connectors ..... Used to connect probes using Probe-DP RS cable.  
Up to 10 probes can be connected simultaneously.  
Keep caps on probe connectors not in use.  
The numbers correspond to the probe numbers to be controlled.  
Do not use both USB and RS-232C simultaneously to connect a single probe.  
Doing so will cause a connection error and disable measurement.

### <Left>

- (4) Remote measurement terminal ..... Used to connect a commercially available remote switch, which serves the same function as the [HOLD] key.
- (5) AC adapter connector..... Used to connect the AC adapter.
- (6) PC Ethernet connector ..... Used to connect to a PC or network using a LAN cable.
- (7) PC USB connector ..... Used to connect a PC using a USB cable.
- (8) PC RS connector ..... Used to connect a PC using an RS-232C cable.
- (9) Vertical synchronization signal input terminal... Used to input the display's vertical synchronization signal for measurement in "EXT" measurement synchronization mode.
- (10) Trigger signal input terminal..... Used to input the trigger signals for measurement when Trigger mode is "ON".

### <Rear>

- (11) Tilt stand
- (12) Battery compartment ..... Remove the screw on the cover to attach or remove the optional lithium-ion battery. (P. 46)
- (13) Bluetooth module slot ..... Remove the screw from the bottom and connect the optional Bluetooth module. (P. 114)
- (14) Screw holes for securing ..... Used for screws when holding the instrument to a monitor arm or other device.

# Display Screen

## 1. Screen configuration

There are two types of screens: basic and pop-up. The basic screen has three areas—status display, setting, and data display.

## 2. Basic screen

The screen shown below is the basic screen, which displays the status of the instrument and data.

### • Status display

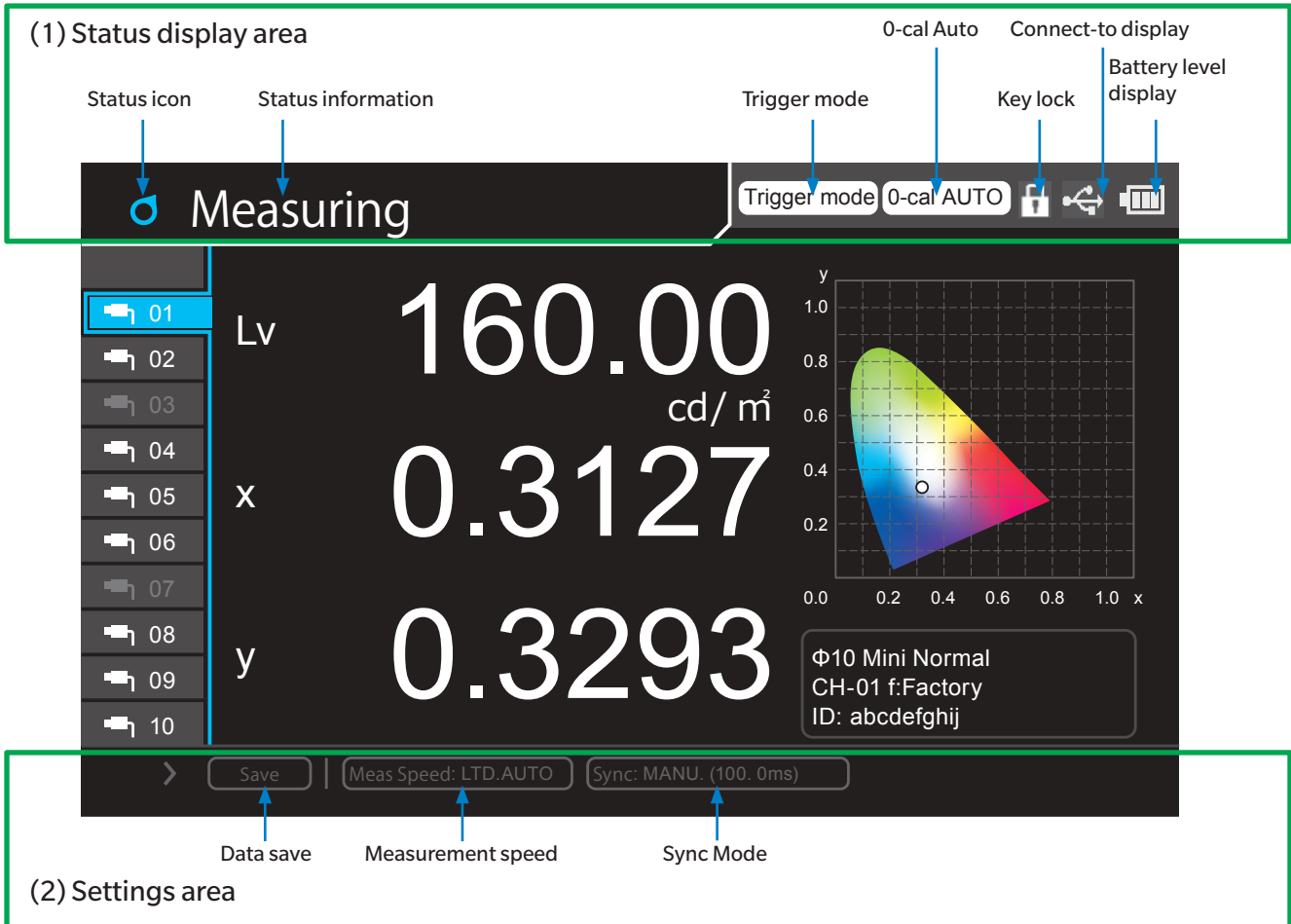

### (1) Status display area

Displays the operating status of the data processor. This is always displayed on the basic screen.

#### • Status icons and status information



	Measuring	During normal measurement
	Hold	In normal measurement hold mode
	Measuring (Interval)	During interval measurement
	Hold (Interval)	Waiting for interval measurement
	Remote	During communication with a PC
	Menu	In menu mode ([MENU] key = ON)
	Select User Calib CH	When a calibration channel is being selected ([CAL CH] key = ON)
	Check Saved Data	In saved data checking mode ([DATA] key = ON)
	Save Meas. Results	During data saving (save icon + ENTER)



- **Trigger mode**

	Trigger mode enabled (Trigger mode ON and interval OFF)
No display	Trigger mode disabled

- **0-cal Auto**





	0-cal Auto ON
	0-cal Auto OFF and when the temperature changes
No display	0-cal Auto OFF and when the temperature doesn't change

- **Key lock**





Press and hold the [ESC] key to lock/unlock the keys. (P. 28)

	Key locked
No display	Key unlocked

- **Connect-to display**

	During communication via USB
	During communication via RS-232C
	During communication via Ethernet
	During communication via Bluetooth
No display	Communication yet to be started

- **Battery level display**

	Operating off battery power with the battery fully charged
	Operating off battery power with the battery sufficiently charged
	Operating off battery power with the battery slightly charged
	Operating off battery power with no battery remaining and measurement disabled
	Charging by the connected AC adapter
No display	Charging completed by the connected AC adapter

## Display Screen

### (2) Settings area

Contains shortcut key icons for saving and setting measurement data.

Shortcut keys in the setting area are not displayed on screens other than the measurement screen (such as the menu screen).

The setting area is enabled only in hold mode. (Single-probe measurement screen and multi-probe measurement screen)

#### Measuring

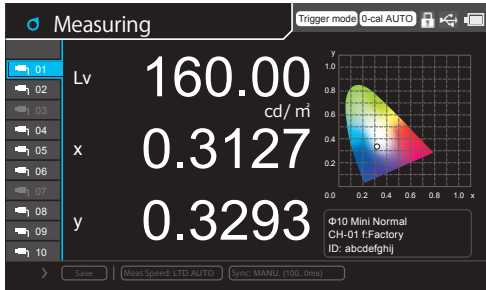

Enabled in hold mode

#### Hold

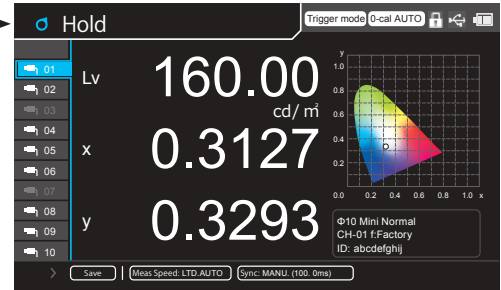

Use the [LEFT/RIGHT] keys to select a shortcut key icon.

Use the [UP/DOWN] key to move selection targets, including the data display area.

Press the [ENTER] key to apply the setting.

#### Measurement speed:

Displays the measurement speed setting. Select this using the [UP/DOWN] and [LEFT/RIGHT] keys, and then press the [ENTER] key to display the measurement speed menu. (The menu for selecting AUTO/LTD.AUTO/FAST/SLOW is displayed)

#### Sync Mode:

Displays the synchronization mode setting. Select this using the [UP/DOWN] and [LEFT/RIGHT] keys, and then press the [ENTER] key to display the synchronization mode menu. (The menu for selecting NTSC/PAL/UNIV./INT[\*\*\*.Hz]/ EXT/MANU.[\*\*\*\*.msec] is displayed. \*\*\* is the currently set value).

However, the mode is switched to UNIV. if the external trigger mode is turned ON in EXT mode.

#### Data Save:

Select this using the [UP/DOWN] and [LEFT/RIGHT] keys, and then press the [ENTER] key to save the displayed measurement results.

### How to Save Data

- 1 Press the [ENTER] key to display the screen for selecting where to save data. Select the destination using the [UP/DOWN] keys, and then press the [ENTER] key.

The screen is not displayed when Save Destination is set to AUTO. In this case, go to step 2.

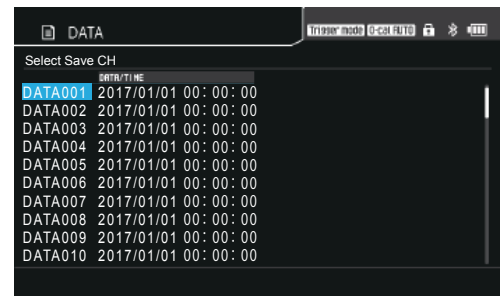

- 2 During saving, a pop-up screen is displayed indicating that data is being saved.

If data already exists, a confirmation message appears first asking whether it is OK to overwrite. Select "Yes" using the [LEFT/RIGHT] key and press the [ENTER] key.



\* Data will not be saved when the difference display is selected.

### (3) Measurement data area

Used to display measured data or configure settings by pressing menu keys.

There are two types of screens that display values being measured: a screen that displays the values measured by a selected single probe and a screen that displays all values measured by multiple probes.

#### (3)-1. Probe selection area

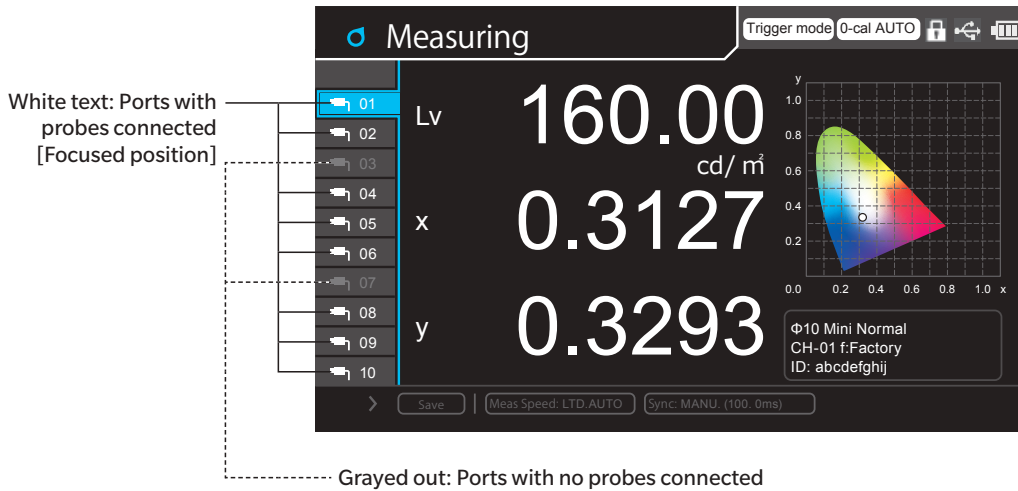

Select the number of a connected port using the [UP/DOWN] keys.

In the single-probe display, only the data measured by the selected probe is displayed.

# Display Screen

## (3)-2. Single-Probe Display

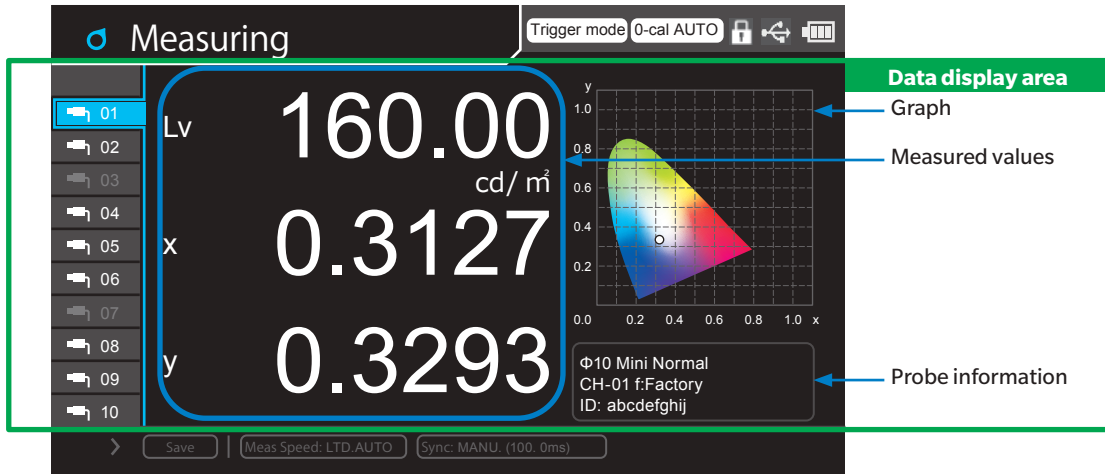

- Selecting the number of a connected port using the [UP/DOWN] keys displays only the data measured by the probe connected to that port.
- The probe information display shows the information of the selected probe.
 

Type:	Probe type	
Selected calibration CH:	CH00 to CH99	
Calibration type:	f:factory	KM factory calibration
	s:user single	User calibration (single-point calibration)
	m:user matrix	User calibration (RGB+W matrix calibration)
	c:user custom	User calibration (with specified calibration coefficients)
ID:	ID set for the probe (half-width alphanumeric and symbols, 10 characters max., blank when not set)	

## (3)-3. Multi-Probe Display

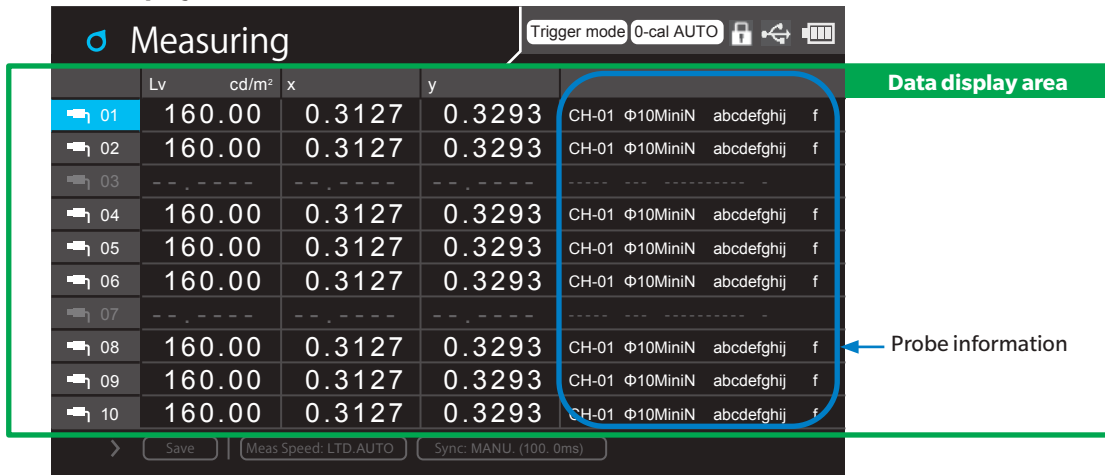

Displays the data measured by multiple probes and the information of the probes. Switching to single-probe display will display only the data measured by the selected probe.

# Operations on Each Screen

## 1. Measurement screen

There are two types of screens that display values being measured: a screen that displays the values measured by a selected single probe and a screen that displays all values measured by multiple probes.

### Single-Probe Display

A screen that displays the values measured by a selected single probe.

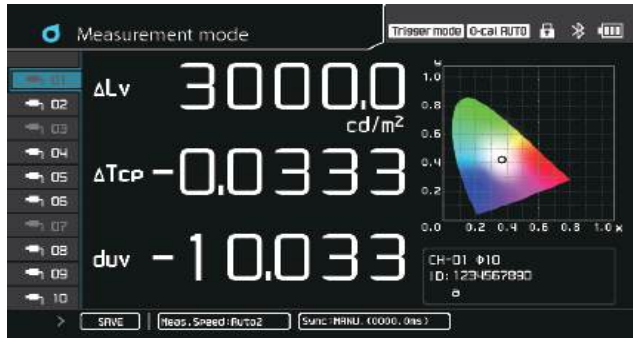

#### Operations possible on this screen

- Press the [HOLD] key to hold the display.
- Shortcut keys are enabled only in hold mode.
- Using the [UP/DOWN] keys to switch the probe whose measured value is to be displayed.
- Pressing the [Enter] key switches to the multi-probe display.

### Multi-Probe Display

A screen that displays the values measured by multiple probes.

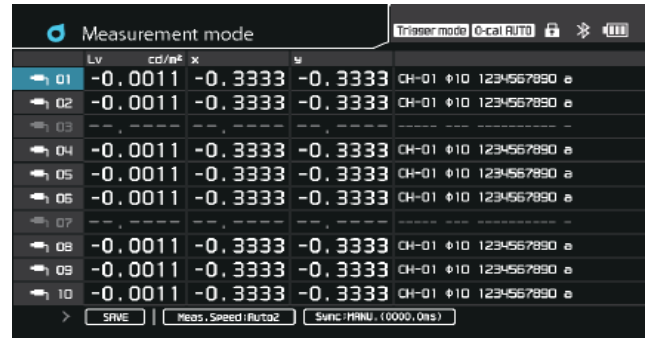

#### Operations possible on this screen

- Press the [HOLD] key to hold the display.
- Shortcut keys are enabled only in hold mode.
- Using the [UP/DOWN] keys to switch the probe whose measured value is to be displayed.
- Pressing the [Enter] key switches to the single-probe display for the currently selected probe.

### • Operations in each measurement mode

Generally, measurement is performed continuously and measured values are updated on the screen. Pressing the [HOLD] key pauses measurement and the values measured last remain on the screen. Pressing the [HOLD] key again starts measurement and resumes screen updates.

In trigger mode, measurement is generally in hold status. If being triggered externally, measurement is performed and measured values on the screen are updated.

In interval measurement mode, measurement is performed at the set interval and measured values on the screen are updated. If the set number of measurements is completed, measurement ends and switches to hold status, and the values measured last remain on the screen. To stop a measurement in progress, press the [HOLD] key.

Although operations shown below are common to the single-probe display and the multiple-probe display, operable items differ between normal, trigger, and interval measurement modes.

## Operations on Each Screen

### • About displays

	In normal measurement (continuous measurement) mode and trigger mode	In interval measurement mode
Measuring (including periods between measurements)	<ul style="list-style-type: none"> <li>Pressing the [MODE] key to change the color space</li> <li>Pressing the [0-Cal] key to perform zero calibration</li> <li>Pressing the [DATA] key to check saved data</li> <li>Pressing the [CAL-CH] key to change the calibration channel</li> <li>Pressing the [MENU] key to configure settings on the menu screen</li> </ul>	
Hold	<ul style="list-style-type: none"> <li>Pressing the [MODE] key to change the color space</li> <li>Pressing the [0-Cal] key to perform zero calibration</li> <li>Pressing the [DATA] key to check saved data</li> <li>Pressing the [CAL-CH] key to change the calibration channel</li> <li>Pressing the [MENU] key to configure settings on the menu screen</li> <li>Pressing the [SAVE] icon to save the data</li> </ul>	<ul style="list-style-type: none"> <li>Pressing the [MODE] key to change the color space</li> <li>Pressing the [0-Cal] key to perform zero calibration</li> <li>Pressing the [DATA] key to check saved data</li> <li>Pressing the [CAL-CH] key to change the calibration channel</li> <li>Pressing the [MENU] key to configure settings on the menu screen</li> </ul>

## 2. Zero calibration screen

### Single-Probe Display

A pop-up screen appears indicating that 0-cal is in progress and disappears when 0-cal is completed.



### Multi-Probe Display

A pop-up screen appears indicating that 0-cal is in progress and disappears when 0-cal is completed for the connected probe.

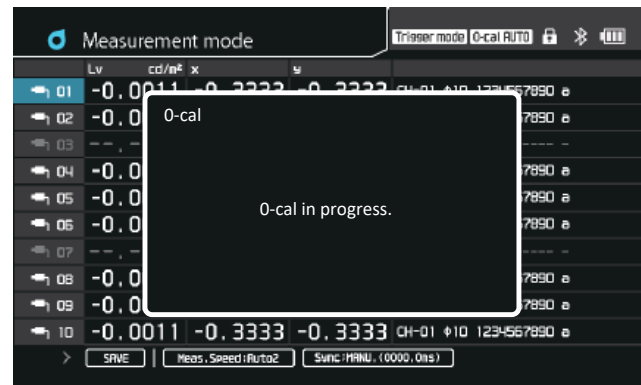

## 3. Screen in remote mode

### Single-Probe Display

Display when only one probe is connected

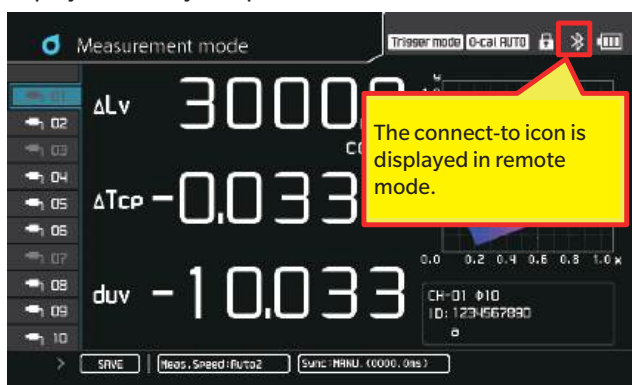

### Multi-Probe Display

Display when multiple probes are connected

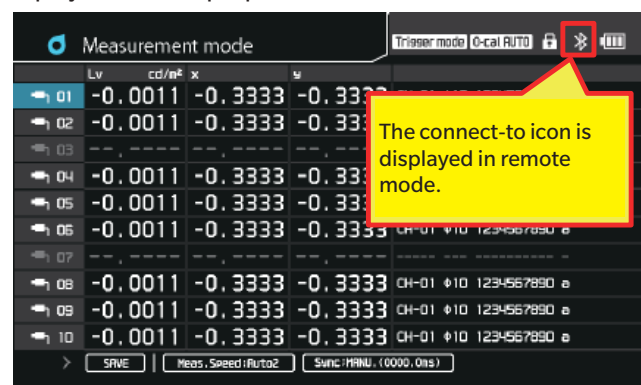

# 4. Changing color modes

Press the [MODE] key to change the color space for the measured values on the screen.

\* CA-VP427, CA-VP402, CA-VP404, and CA-VP410T probes cannot measure flicker.

\* The displayed color mode screens are only those checked in Color Space under Menu - Option.

\* Color modes cannot be changed in interval measurement mode.

## Transition of color mode screens - Single-probe display



## Multi-probe display

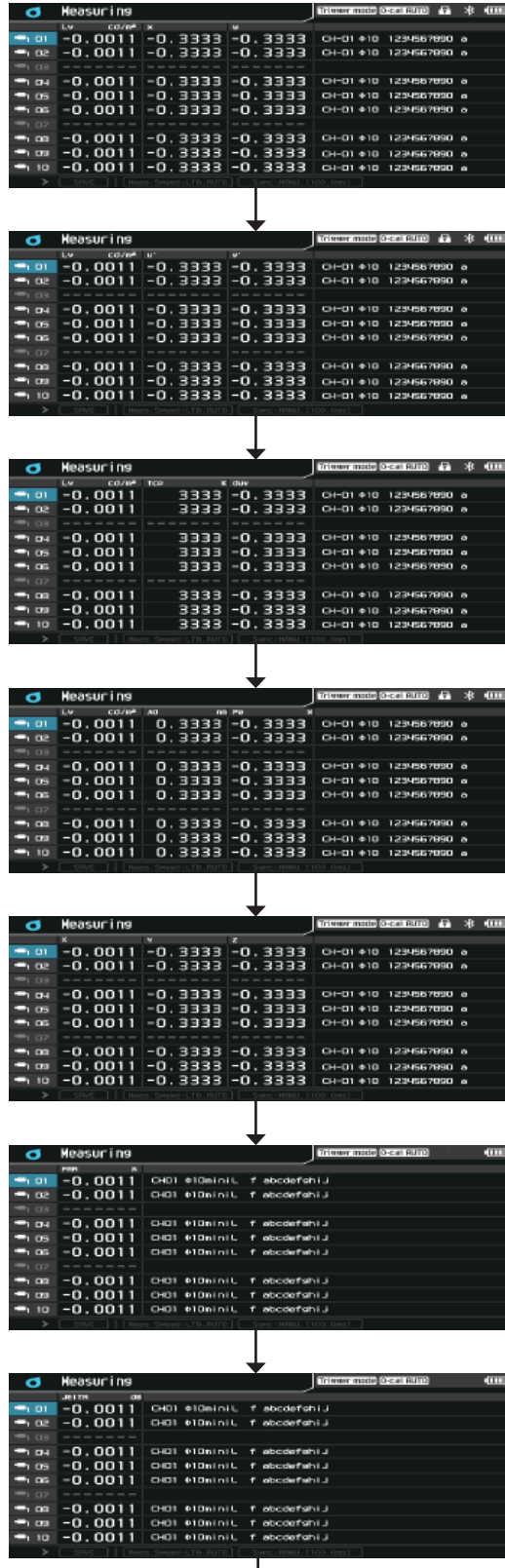

CA-DP40

## 5. Graph

The following graphs are displayed on the screen for the measurement results of a single probe.

**When the color mode is Lv,x,y, Lv,Tcp,duv, X,Y,Z, Lv,Tcp,duv, or Lv, $\lambda$ d,Pe**

- An xy chromaticity diagram is displayed.

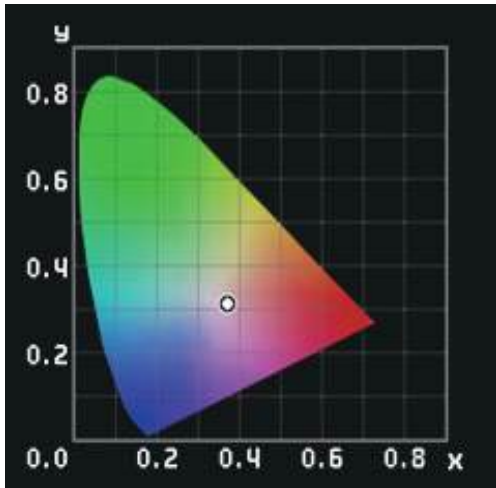

**When the color mode is Lv,u'v'**

- A u'v' chromaticity diagram is displayed.

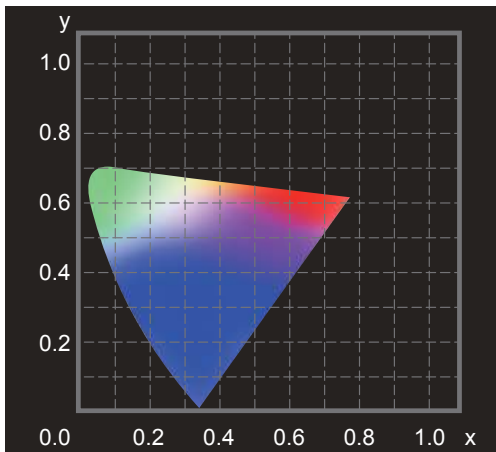

**When the color mode is JEITA**

- JEITA frequency and time characteristic diagrams are displayed.

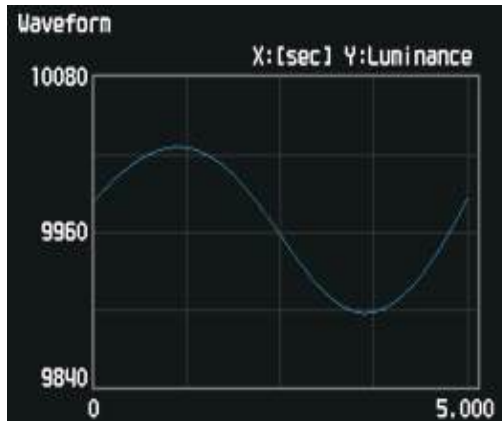
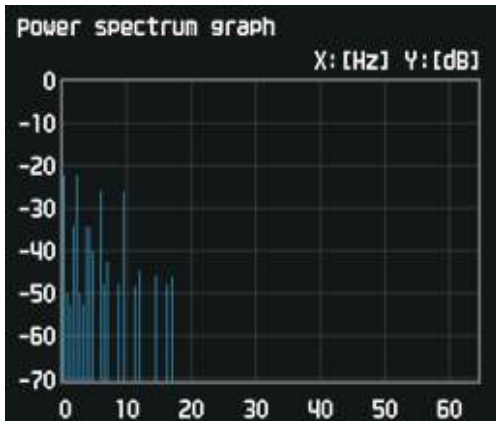

**When the color mode is FMA**

- No graph is displayed.



## 6. Menu screen

Press the [MENU] key to change probe or data processor settings.

The menu screen includes areas 1 to 3, and options for the item selected in area 1 are displayed in area 2, and options or settings for the item selected in area 2 are displayed in area 3.

- Select an item in area 2 after selecting an item in area 1 using the [UP]/[DOWN] keys and pressing the [RIGHT] or [ENTER] key.
- After selecting an item in area 2 using the [UP]/[DOWN] keys and pressing the [RIGHT] or [ENTER] key, the settings are displayed or an item in area 3 can be selected. Pressing the [LEFT] or [ESC] key returns to item selection in area 1.
- After selecting an item in area 3 using the [UP] or [DOWN] key and pressing the [RIGHT] or [ENTER] key, the setting screen for the item is displayed. Pressing the [LEFT] or [ESC] key returns to item selection in area 2.

\* For items to set, refer to the Settings section.

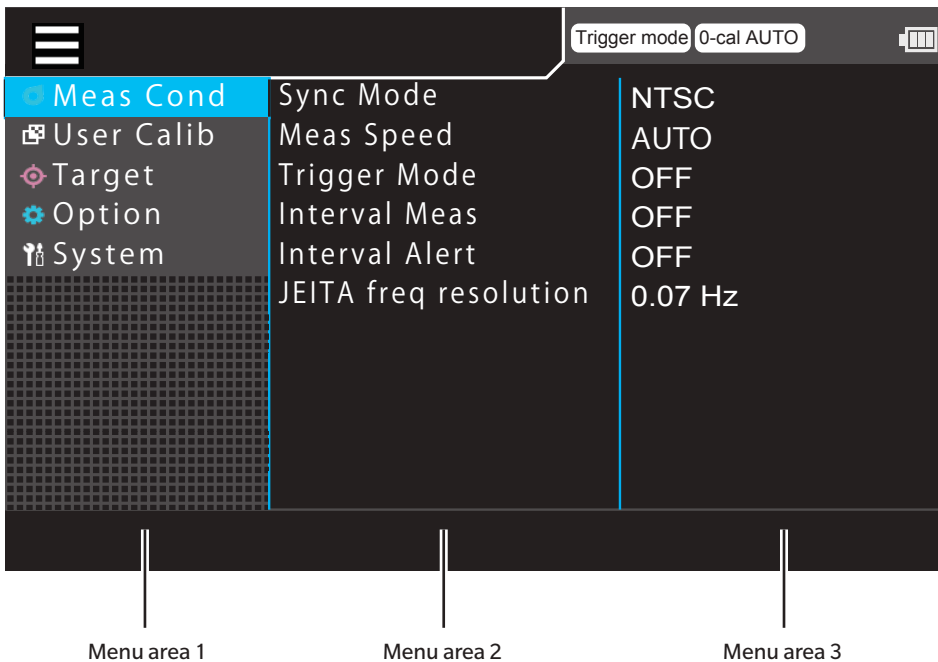

# Manual Structure

This manual is divided into sections as shown below according to the contents.

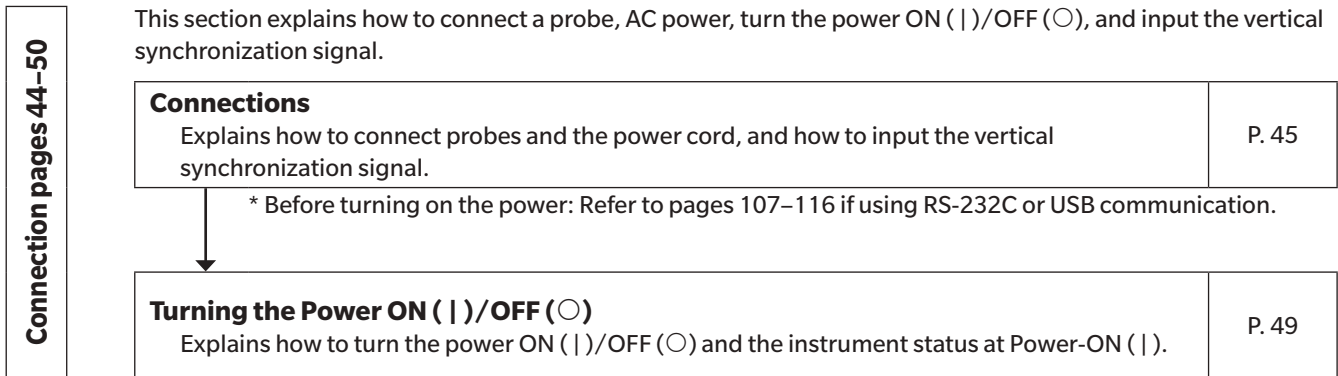

- The Measurement Preparation, Calibration/Settings, and Measurement sections explain the procedure up to measurement.

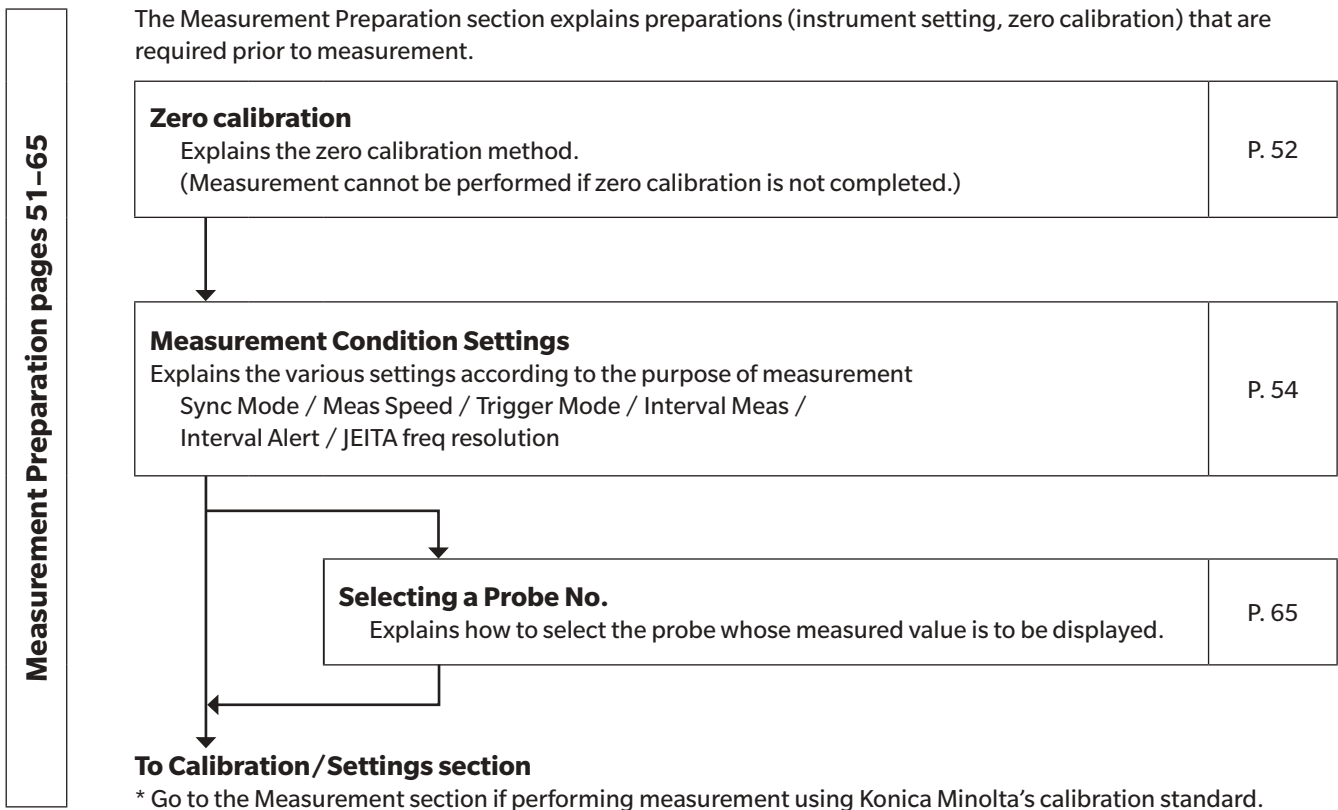

This section explains settings that must be configured according to measurement method. The setting method varies according to the measurement method.

**From the Measurement Preparation section**

<p><b>Outline of the Calibration / Settings Section</b> Explains measurement method types and settings that must be configured. (Check which settings must be configured.)</p>	P. 67
--	-------

<p><b>Before Configuring Each Setting</b> Gives detailed explanations on calibration channels common to each setting and target values.</p>	P. 68
---	-------

When performing measurement using Konica Minolta's calibration standard

When performing measurement using user calibration

<p><b>Setting / Changing the Target**1</b> Explains how to set/change the target value. 1. Setting / Changing the Target Value by Measurement 2. Setting / Changing the Target Value by Entering Values</p>	P. 82
---	-------

<p><b>User calibration</b> Gives detailed explanations on user calibration and explains the execution method (as well as setting target values).</p>	P. 70–73
--	----------

- To change the target value after user calibration: Refer to page 82 "Setting / Changing the Target"\*\*.1.

- To set an ID: page 78 "Setting an ID"\*\*.2.

**To the Measurement section**

<p><b>Other Settings</b> Explains how to set an ID**2.</p>	P. 78
--	-------

<p><b>Settings Check Method</b> Settings can be checked from Menu area 3.</p>	P. 39
---	-------

Measurement pages 86-91

This section explains measuring methods.

**From Calibration/Settings section**



<p><b>Measurement</b> Explains measuring methods, how to hold the measured values, how to read them, and how to clear them.</p>	<p>P. 87</p>
---	--------------

Communication pages 107-116

This section explains communication with a PC via RS-232C, USB, Ethernet, or Bluetooth.

<p><b>Connection to a PC via RS-232C</b> Explains how to connect an RS-232C cable and select the RS-232C baud rate to enable two-way communication with a PC or other device via RS-232C.</p>	<p>P. 108</p>
---	---------------

<p><b>Connection to a PC via USB</b> Explains how to connect a cable to enable communication with a PC via USB.</p>	<p>P. 110</p>
---	---------------

<p><b>Connection to a PC via Ethernet</b> Explains how to connect a cable and set the DHCP to enable communication with a PC via Ethernet.</p>	<p>P. 111</p>
--	---------------

<p><b>Connection to a PC via Bluetooth</b> Explains how to connect and set the Bluetooth module to enable communication with a PC or other device via Bluetooth.</p>	<p>P. 114</p>
--	---------------

**Communicating with a PC**

- Bidirectional communication is possible between the data processor and a PC using an RS-232C, USB, Ethernet, or Bluetooth connection.  
When multiple means of communication are set, the means of communication used for sending the first command from the PC will be enabled, and commands from all other means will be ignored.
- If the USB cable will be connected and disconnected frequently, please try to use RS-232C for connection. If any problem occurs, contact a Konica Minolta-authorized service facility.

This section explains the following items.

<p><b>Dimensions</b></p>	<p>P.118</p>
<p><b>Error Messages</b> Please read when an error message appears on the LCD display.</p>	<p>P. 119</p>
<p><b>Main Specifications</b></p>	<p>P. 120</p>

# Connection

This section explains how to connect a probe, AC power, turn the power ON (|)/OFF (○), and input the vertical synchronization signal.

<b>Connections</b> Explains how to connect probes and the power cord, and how to input the vertical synchronization signal.	P. 45
* Before turning on the power: Refer to pages 107–116 if using RS-232C or USB communication.	
<b>Turning the Power ON ( )/OFF (○)</b> Explains how to turn the power ON ( )/OFF (○) and the instrument status at Power-ON.	P. 49

# Connections

## 1. Connecting a Probe to the Data Processor

Before setting the POWER switch to ON, connect a probe to a probe connector.

- A probe can be connected with an USB cable or an RS cable.
  - For RS-232C connection, connect the mini DIN plug of the Probe-DP RS cable IF-A30 (or IF-A31 or IF-A32) supplied with the data processor to the RS-232C connector of the probe and the probe RS-232C connector of the CA-DP40 data processor.
  - For USB connection, connect the USB mini B plug of the supplied USB cable IF-A28 to the USB connector of the probe. Connect the USB plug on the other side of the cable to the probe USB connector of the CA-DP40 data processor.

### How to Connect

- 1 Set the POWER switch to OFF.**
- 2 Connect the probe's plug into a probe connector on the instrument.**
- 3 Check that the plug is inserted all the way and connected firmly.**
  - When disconnecting the probe, set the POWER switch to OFF first, and pull the probe by holding the plug. Never pull the cable by its cord.

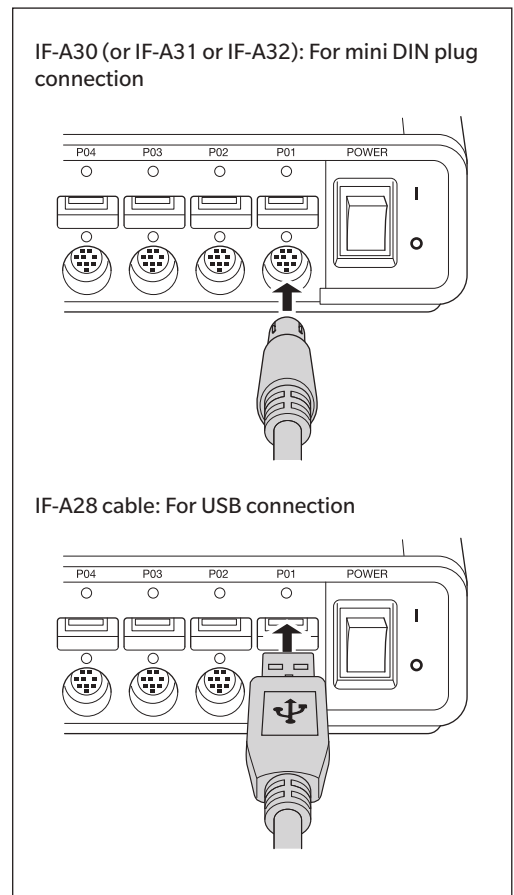

### Notes on Connecting Probes

- Never connect or remove a probe while the POWER switch is ON ( | ).
- When connecting/disconnecting a probe, always hold the plug to connect/disconnect it. In addition, do not pull or bend the cord excessively or exert excessive force on it. Doing so may cause the cable or cord to break.
- The luminance range will vary according to the type of probe.
- Use either RS-232C or USB to connect a probe. Using both for connection will cause an error.
- For each probe, 5 V/300 mA power is required. It is recommended that the AC adapter be used as necessary. It is also recommended that probes be disconnected when not in use.

Up to 10 probes can be connected simultaneously. Because the type of display to be measured and the measuring luminance range of the probe vary according to the type, please install one that is fit for use. Also, different types can coexist. Keep caps on probe connectors not in use.

## 2. Attaching/Detaching a Battery

This instrument uses a dedicated lithium-ion battery (CM-A223).

### CAUTION

- Do not use any battery other than the dedicated lithium-ion battery. Doing so may cause the battery to rupture or result in decreased battery life.
- Do not touch or short-circuit the terminals in the battery compartment. Doing so may damage the instrument.

### How to Attach

**1** Turn the power OFF.

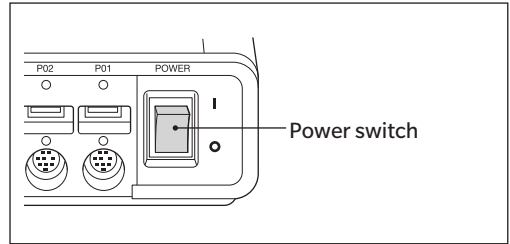

**2** Open the battery compartment cover located on the back of the data processor.

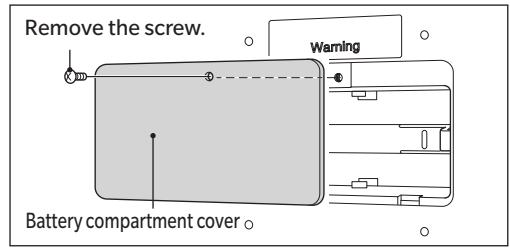

**3** While pressing on the lithium-ion battery, slide the battery until a “click” can be heard. To detach the battery, slide it in the opposite direction.

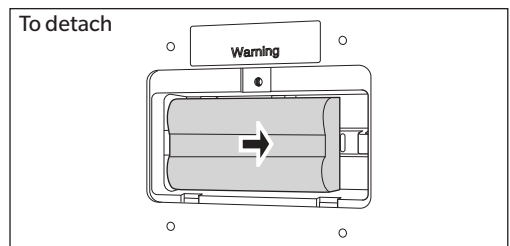
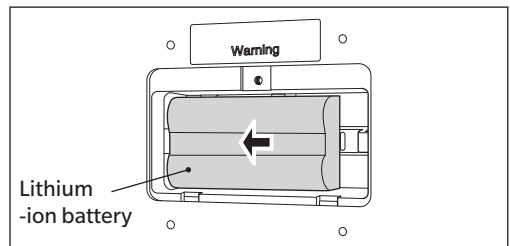

**4** Screw the battery compartment cover to close it.

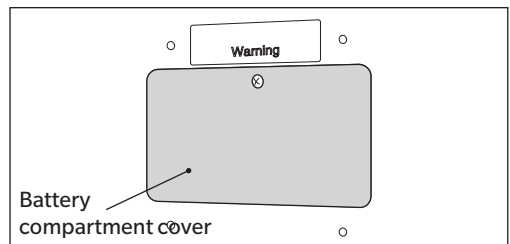



### 3. Connecting the AC Adapter

#### ⚠ CAUTION

- Be sure to use the supplied AC adapter AC-A312F.
- Before connecting or disconnecting the AC adapter jack or plug, make sure that the instrument is turned OFF.
- Firmly push the AC adapter power plug completely into the outlet.

#### Operating Procedure

- 1 Turn the power OFF.
- 2 Connect the connector plug of the AC adapter to the AC adapter input terminal.
- 3 Connect the AC adapter plug to a 100 to 240 V (50/60 Hz) AC outlet.

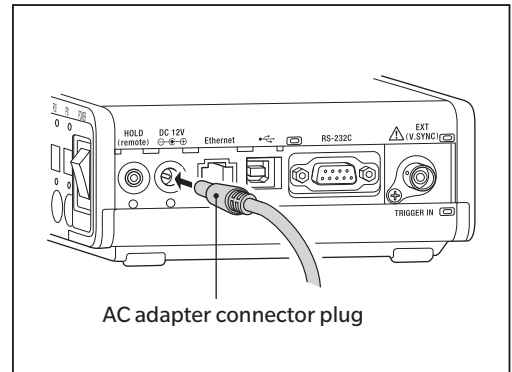

### 4. Vertical synchronization signal input

The vertical synchronization signal from the display can be input to the instrument to allow synchronous measurement (when EXT is selected as the measurement synchronization mode).

However, if another measurement synchronization mode is selected, it is not necessary to input the vertical synchronization signal.

The signal can be input directly to a probe or to the data processor.

For how to input the signal directly to a probe, refer to the description of probe setting (P. 16).

To input the signal to the data processor, connect an input cable with a BNC connector to the vertical synchronization signal input terminal on the side, and input the vertical synchronization signal used for the display (a frequency between 0.50 to 240.00 Hz). Before connection, be sure to set the power switches of the data processor and the external device to OFF.

For flicker measurement, input a vertical synchronization signal with a frequency between 0.50 to 130.00 Hz.

\* Set the measurement synchronization mode to EXT to synchronize measurement with the display's vertical synchronization signal. For details, refer to page 20.

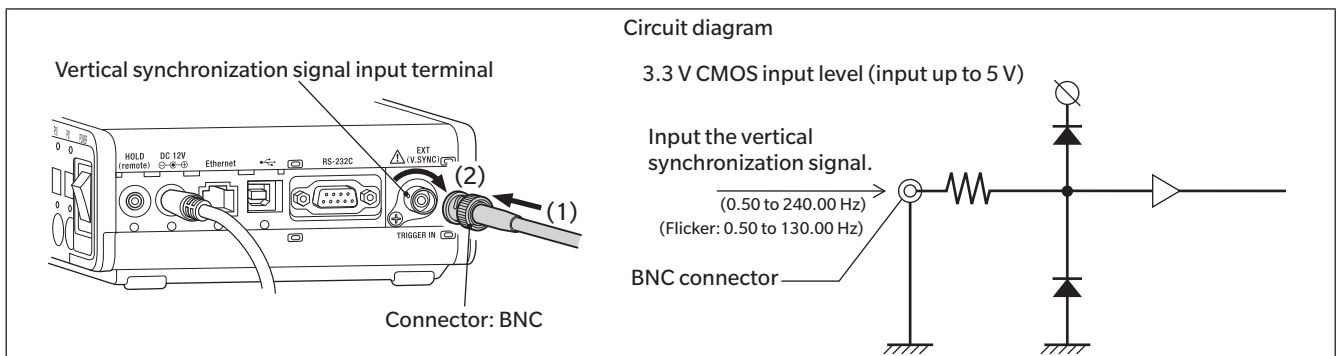

⚠ Be sure to connect a cable to the specified terminal.

### 5. Connecting a Remote Switch

Connecting a commercially available remote switch serves the same function as the HOLD key.

#### CAUTION

- Before connecting or disconnecting the AC adapter jack or plug, make sure that the instrument is turned OFF.

#### Operating Procedure

- 1** Turn the power OFF.
- 2** Connect the switch to the remote switch input terminal.

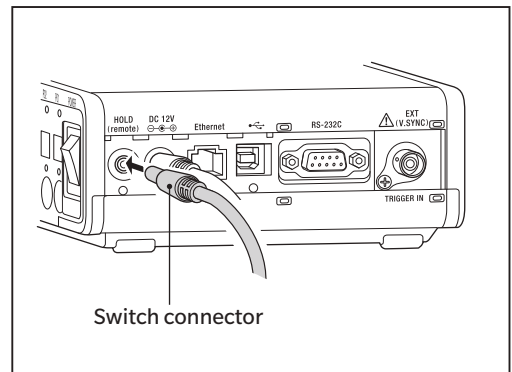

# Turning the Power ON/OFF

## 1. Turning the Power ON/OFF

Before setting the POWER switch to ON, complete the following. When turning the power ON for the first time after purchase, the language selection and date/time setting screens appear. Set the display language and the date/time on these screens.

### Operating Procedure

#### 1 Connect a probe to a probe connector. (P. 16)

- To synchronize measurement with the display's vertical synchronization signal (EXT is selected as the measurement synchronization mode)
  - Input the vertical synchronization signal that is used for the display. (P. 18)
- To perform measurement simultaneously with multiple probes
  - Connect the necessary number of probes to the probe connectors. (P. 17–18)
- To communicate with a PC via RS-232C
  - Connect the instrument to the PC using an RS-232C cable. (P. 108)
  - On the menu selection screen, select the RS-232C baud rate. (P. 109)
- To communicate with a PC via USB
  - Connect the instrument to the PC using a USB cable. (P. 110)
- To communicate with a PC via Ethernet
  - Connect the instrument to the PC using a LAN cable. (P. 111)
  - On the menu selection screen, set the IP address, subnet mask, and default gateway. (P. 112)

#### 2 Connect the power cord to an outlet. (P. 47)

##### Turning the Power ON

Set the POWER switch to ON.

- When turning the power ON for the first time after purchase, the language and internal clock setting screens appear. Set the display language and the date/time on these screens by referring to pages 102 and 104.

##### Turning the Power OFF (○)

Set the instrument's POWER switch to OFF (○).

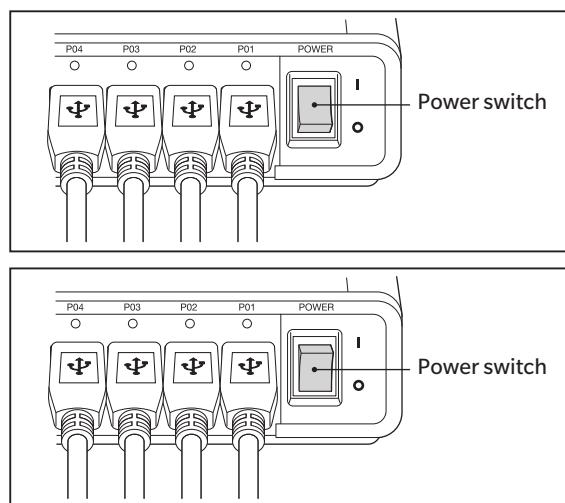

**Error Messages on the LCD Display: For other error messages, refer to page 119.**

##### “Probe connection error”

- Cause:** A probe was connected or disconnected while the POWER switch was ON.
- Action:** Set the POWER switch to OFF first, connect necessary probes, then set the POWER switch to ON. (Before connecting/disconnecting a probe, make sure that the POWER switch is set to OFF.)

## 2. Instrument Status at Power-ON

---

By default, the instrument is in the following status when the POWER switch is set to ON.

1	Color Mode	P. 94	Lvxy
2	Calibration channel No.	P. 68	CH 00
3	Target Value	P. 82	x = 0.3127, y = 0.3290, Lv = 100.0 (cd/m <sup>2</sup> )
4	PROBE	P. 65	P1
5	SYNC (measurement synchronization mode)	P. 56	UNIV.
6	ID	P. 78	CH 00
7	Measurement speed	P. 54	AUTO
8	RS-232C baud rate	P. 109	38400 bps
9	Correction coefficient for user calibration	P. 69	Konica Minolta's standard data

### Changing Method for (1) and (2)

(1) Color Mode ..... Press the **MODE** MODE key.

(2) Calibration channel ..... Press the [CAL CH] key followed by the [UP] or [DOWN] key.

### Changing Method for (3)

(3) Target value..... The current target value will be changed if a mode other than flicker is selected and a target value is entered.

### Changing Method for (4) to (9)

For (4) to (9), press the [MENU] key to display the menu screen, then switch to a relevant screen for setting.

# Measurement Preparation

The Measurement Preparation section explains preparations (instrument setting, zero calibration) that are required prior to measurement.

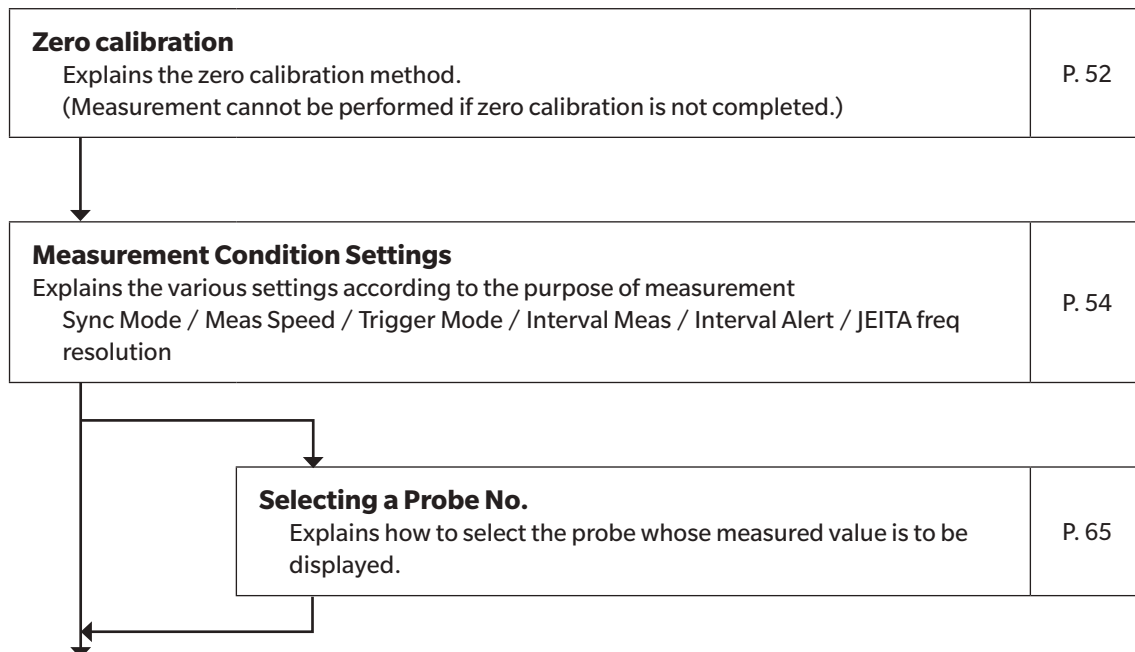

**To the Settings section**

\* Go to the Measurement section if performing measurement using Konica Minolta's calibration standard.

# Zero calibration

---

Zero calibration performs zero point adjustment while blocking entry of light into the probe's receptor. A shutter located inside the probe automatically closes to block light during zero calibration of the instrument. Zero calibration must be performed whenever the POWER switch is set to ON (|).

## 1. Performing Zero Calibration

---

### Notes on zero calibration

- Perform zero calibration if the ambient temperature has changed. If "Auto 0-cal" is set to ON, zero calibration is performed automatically when the ambient temperature has changed. (Refer to [Option] - [0-Cal])
- Perform zero calibration at any time by pressing the [0-Cal] key.
- Do not direct the end of the probe toward an illuminant with high luminance during zero calibration.
- Never press any keys during zero calibration. Doing so will cause completion of zero calibration to take more time.
- Zero calibration will be performed simultaneously with all the connected probes.

### Operating Procedure

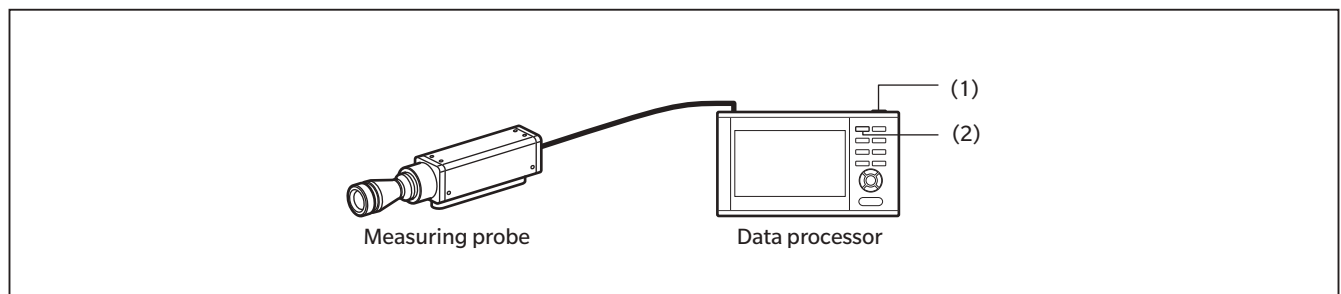

Before starting zero calibration, check that a probe is connected to a probe connector.

- 1 Check that the POWER switch is set to ON (|).**
- 2 Press the [0-CAL] key.**  
Measurement will start automatically at the end of zero calibration.

---

**Error Messages on the LCD Display:** For other error messages, refer to page 119.

● **“0-cal Error”**

- Cause: Excessively strong light is entering the probe’s receptor.
- Action: Retry 0-cal.  
In such cases, turn the power OFF and back ON if possible, and then retry 0-cal.  
If the same error occurs again, the light-receiving circuit is faulty.  
If zero calibration can be performed correctly by shielding the light-receptor on the tip of the probe, the light shield built into the probe is faulty.  
In either case, contact a KONICA MINOLTA-authorized service facility.

## 2. How to Check Zero Calibration

---

To check whether zero calibration has been performed correctly, block entry of light into the end of the probe using a blackout curtain, etc., so that the receptor is not exposed to light.

- Zero calibration has been performed correctly if zero is displayed for the Lv section on the controller’s measured value display. If a value other than zero is displayed, perform zero calibration again.

The Sync Mode is a mode to perform measurement in synchronization with the fluctuation frequency of a light source that fluctuates brightness at a constant cycle, such as the vertical synchronization frequency of a display unit.

- \* Synchronization frequency setting range: 0.50 to 240.00 Hz
- \* Factory setting: UNIV.

## Operating Procedure

- 1 While the measurement screen is displayed, press the [MENU] key.**  
The setting screen is displayed on the LCD screen.
- 2 Press the [UP] or [DOWN] key to select [Meas Cond], and then press the [RIGHT] or [ENTER] key.**
- 3 Press the [UP] or [DOWN] key to select [Sync Mode], and then press the [ENTER] key.**
- 4 The screen for selecting a Sync mode is displayed. Press the [UP] or [DOWN] key to select a Sync mode.**
  - When selecting NTSC, sampling is performed using a frequency of 59.94 Hz and an integration time of 33.3 msec.
  - When selecting PAL, sampling is performed using a frequency of 50 Hz and an integration time of 40.0 msec.
  - When selecting UNIV, sampling is performed using an integration time of 100 msec.
  - When selecting INT, also set a frequency. (Generally 0.50 to 240.00 Hz, but 0.50 to 130.00 Hz for FMA)
  - When selecting EXT, input the synchronization signal to the probe or the instrument.
  - When selecting MANUAL, also set an integration time. (4.0 to 4000.0 msec)
- 4 -1-1 When selecting [INT], press the [ENTER] key to display the screen for setting a synchronization frequency.**

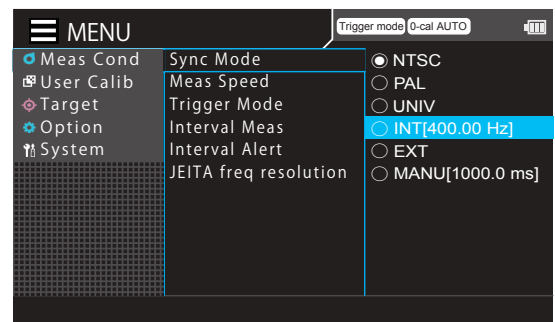
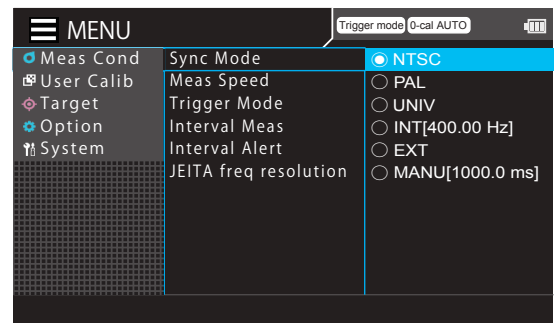
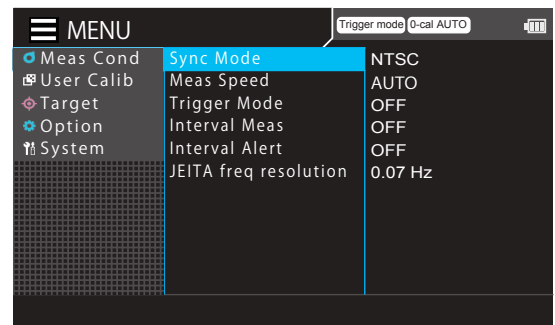
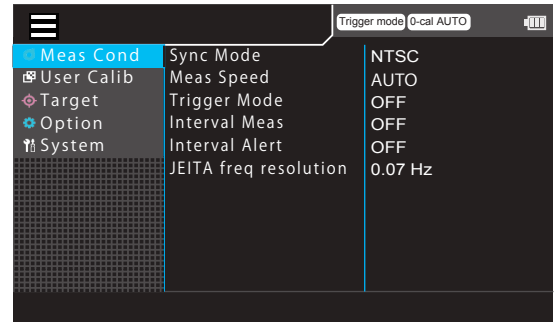



**4 -1-2 Press the [UP] or [DOWN] key and the [RIGHT]/[LEFT] keys to set a synchronization frequency, move to [Complete], and then press the [ENTER] key.**

To cancel entry, press the [ESC] key to return to the previous screen and reset the value. If the entered value is out of the available range, an alert screen is displayed. Press the [ENTER] key to return to the previous screen and reset the value.

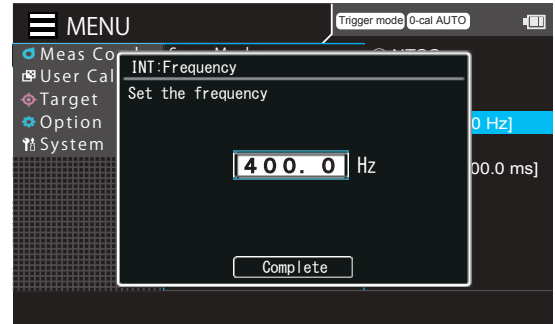

**4 -2-1 When selecting [MANU], press the [ENTER] key to display the screen for setting the integration time.**

**4 -2-2 Press the [UP] or [DOWN] key and the [RIGHT]/[LEFT] keys to set an integration time, move to [Complete], and then press the [ENTER] key.**

To cancel entry, press the [ESC] key to return to the previous screen and reset the value. If the entered value is out of the available range, an alert screen is displayed. Press the [ENTER] key to return to the previous screen and reset the value.

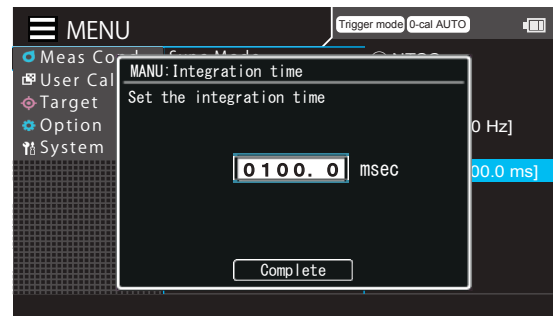
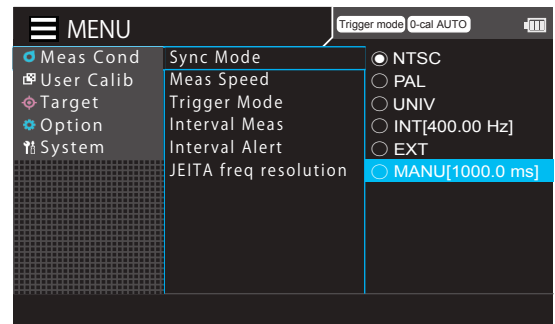

**5 Press the [ESC] key twice.**

The measurement screen is displayed on the LCD screen.

The Sync mode setting will be kept even if the POWER switch is set to OFF (○).

Set the speed for measurement.

\* Selectable measurement speeds: FAST/ SLOW / AUTO / LTD.AUTO

\* Factory setting: AUTO

## Operating Procedure

**1 While the measurement screen is displayed, press the [MENU] key.**  
The setting screen is displayed on the LCD screen.

**2 Press the [UP] or [DOWN] key to select [Meas Cond], and then press the [RIGHT] or [ENTER] key.**

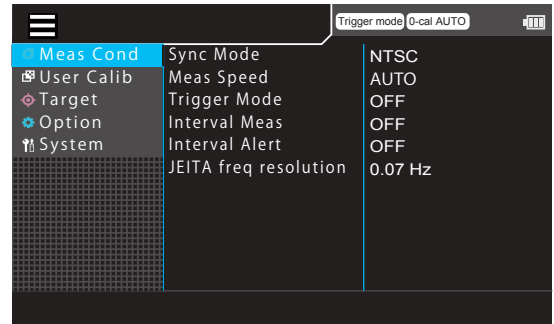

**3 Press the [UP] or [DOWN] key to select [Meas Speed], and then press the [ENTER] key.**

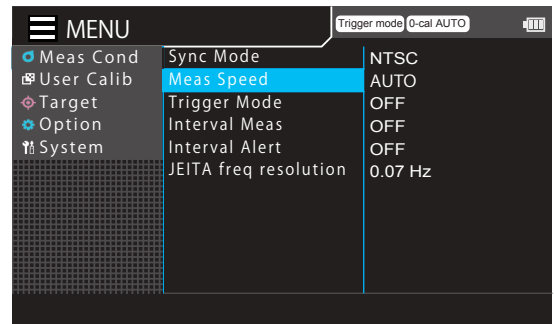

**4 The screen for selecting a measurement speed is displayed. Press the [UP] or [DOWN] key to select a measurement speed.**

- Selecting FAST can shorten measurement time, but may compromise measurement repeatability for low-luminance measurements.
- Selecting SLOW repeats FAST measurements several times to ensure enhanced accuracy. Use this mode when you want to perform measurement with high repeatability.
- When AUTO is selected, the setting automatically switches between “FAST”, “SLOW”, and “Longer Integration Time” depending on the luminance level.
- When LTD.AUTO is selected, measurements are automatically selected between FAST and SLOW settings depending on the luminance level.

**5 Press the [ESC] key twice.**  
The measurement screen is displayed on the LCD screen.  
The measurement speed setting will be kept even if the POWER switch is set to OFF (○).

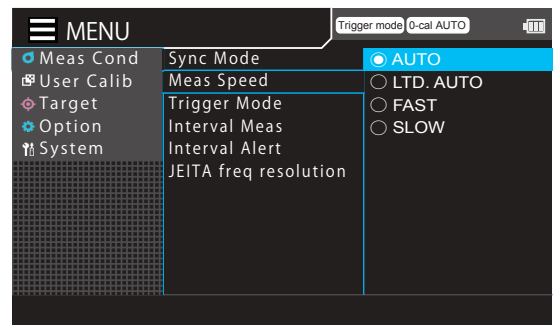

# Setting the Trigger Mode

[Meas Cond] - [Trigger]

In trigger mode, measurement is started by an external trigger. A delay time can be set for starting measurement after a trigger.

\* Factory setting: OFF

## Operating Procedure

- 1 While the measurement screen is displayed, press the [MENU] key.**  
The setting screen is displayed on the LCD screen.
- 2 Press the [UP] or [DOWN] key to select [Meas Cond], and then press the [RIGHT] or [ENTER] key.**
- 3 Press the [UP] or [DOWN] key to select [Trigger Mode], and then press the [ENTER] key.**
- 4 The screen for turning the trigger mode ON/OFF is displayed. Press the [UP] or [DOWN] key to select [ON] or [OFF].**
- 5 When selecting [ON], press the [ENTER] key to display the screen for setting [Delay].**

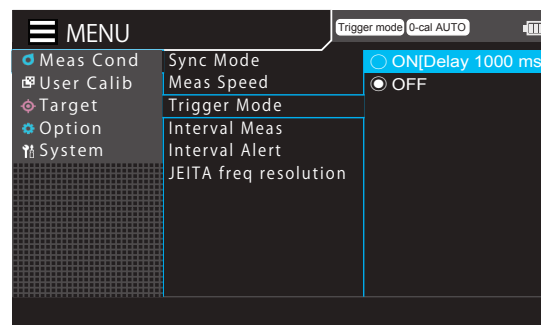
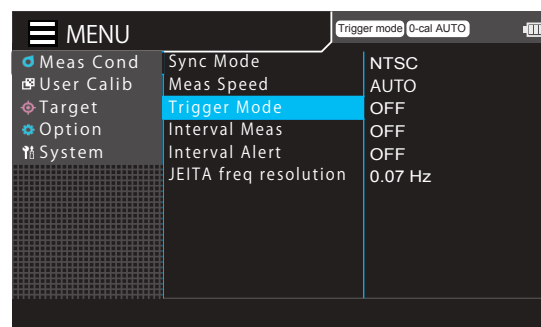
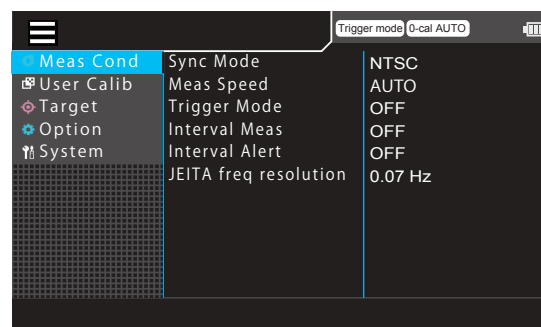

CA-DP40

Measurement Preparation

## Setting the Trigger Mode

### 6 Press the [UP] or [DOWN] key and the [RIGHT]/[LEFT] keys to set a delay time, move to [Complete], and then press the [ENTER] key.

- \* The delay time can be set to between 0 to 1,000 msec.  
If the entered value is out of the available range, an alert screen is displayed. Press the [ENTER] key to return to the previous screen and reset the value.  
Press the [ESC] key to cancel configuration of the setting and restore the original value.

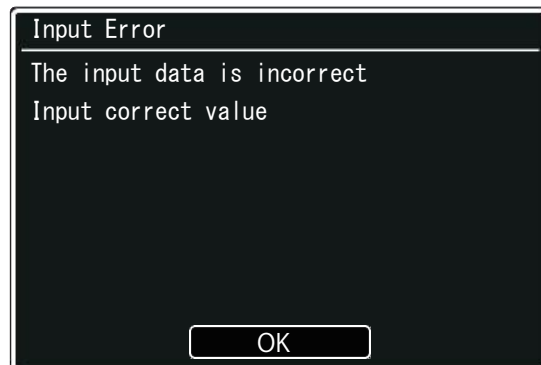
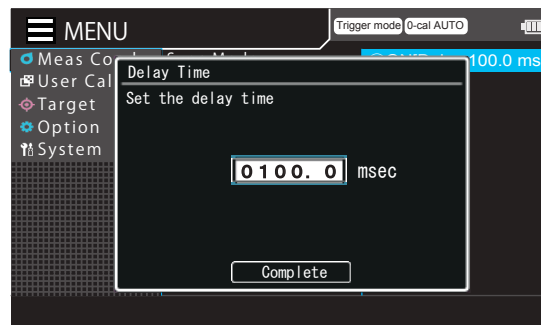

### 7 Press the [ESC] key twice.

- The measurement screen is displayed on the LCD screen.  
The trigger mode setting and value will be kept even if the POWER switch is set to OFF (○).

# Setting the Interval Measurement

[Meas Cond] - [Interval Meas]

The mode can be set to Interval Meas. In this mode, the measurement interval and the number of measurements can be set.  
\* Factory setting: OFF

## Operating Procedure

- 1 While the measurement screen is displayed, press the [MENU] key.**  
The setting screen is displayed on the LCD screen.
- 2 Press the [UP] or [DOWN] key to select [Meas Cond], and then press the [RIGHT] or [ENTER] key.**
- 3 Press the [UP] or [DOWN] key to select [Interval Meas], and then press the [ENTER] key.**
- 4 The screen for turning the interval measurement ON/OFF is displayed. Press the [UP] or [DOWN] key to select [ON] or [OFF].**
- 5 When selecting [ON], press the [ENTER] key to display the screen for selecting [Interval time] and [Interval number].**
- 6 Press the [UP] or [DOWN] key to select [Interval time] or [Interval number], and then press the [ENTER] key.**  
Select [Interval time] and [Interval number], respectively, and go to step 7 to set each value.

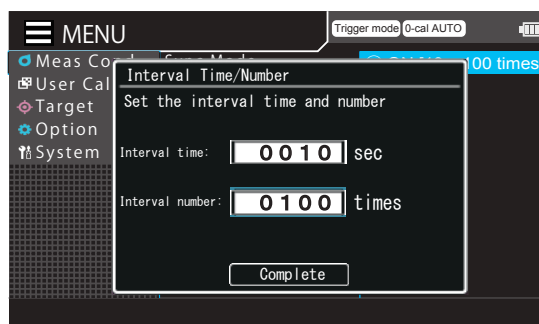
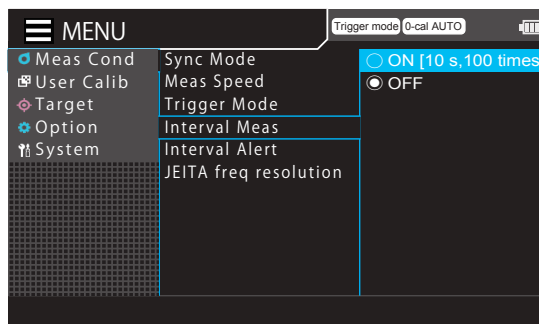
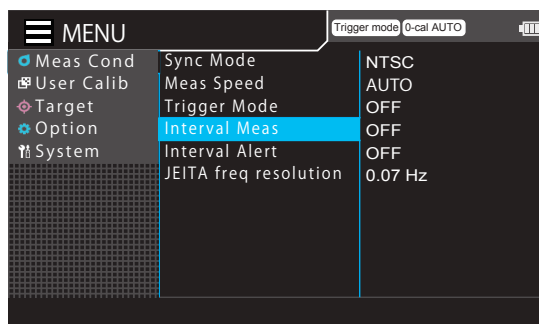
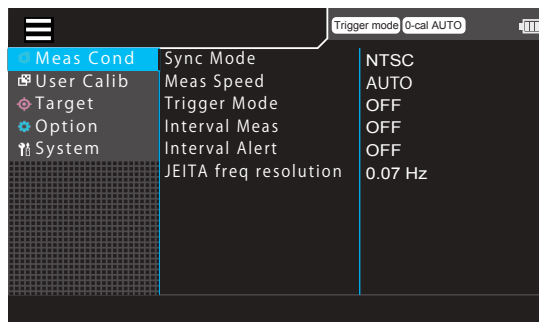

CA-DP40

Measurement Preparation

## Setting the Interval Measurement

---

**7** Press the [UP] or [DOWN] key and the [RIGHT]/[LEFT] keys to set a value, move to [Complete], and then press the [ENTER] key.

\* The interval time can be set to between 1 to 3,600 sec and the interval number to between 1 to 9,999. If the entered value is out of the available range, an alert screen is displayed. Press the [ENTER] key to return to the previous screen and reset the value.

Press the [ESC] key to cancel configuration of the setting and restore the original value.

**8** Press the [ESC] key twice.

The interval measurement screen (Hold) is displayed on the LCD screen. Press the [HOLD] key to begin interval measurement.

The interval measurement setting and value will be kept even if the POWER switch is set to OFF (○).

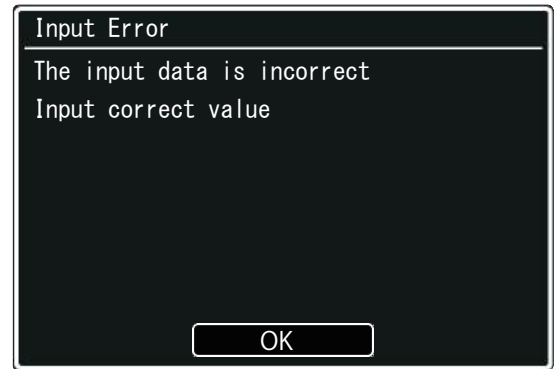

# Setting the Interval Alert

[Meas Cond] - [Interval Alert]

This setting determines whether an alert is displayed during interval measurement when a measured value differs substantially from the one measured immediately before. Set a judgment threshold for outputting an alert. After a threshold is set, a measured value will be saved together with an alert if the difference between the value and the previous one exceeds the threshold.

\* Factory setting: OFF

## Operating Procedure

- 1 While the measurement screen is displayed, press the [MENU] key.**  
The setting screen is displayed on the LCD screen.
- 2 Press the [UP] or [DOWN] key to select [Meas Cond], and then press the [RIGHT] or [ENTER] key.**
- 3 Press the [UP] or [DOWN] key to select [Interval Alert], and then press the [ENTER] key.**
- 4 The screen for turning the interval alert ON/OFF is displayed. Press the [UP] or [DOWN] key to select [ON] or [OFF].**
- 5 When selecting [ON], press the [ENTER] key to display the screen for setting a threshold.**

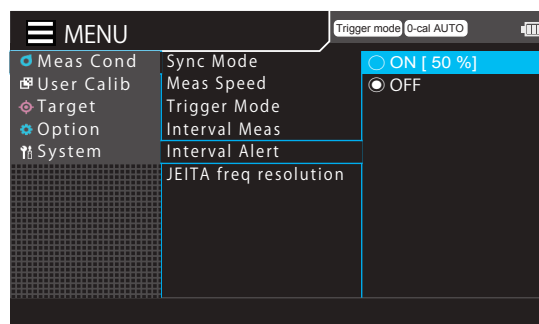
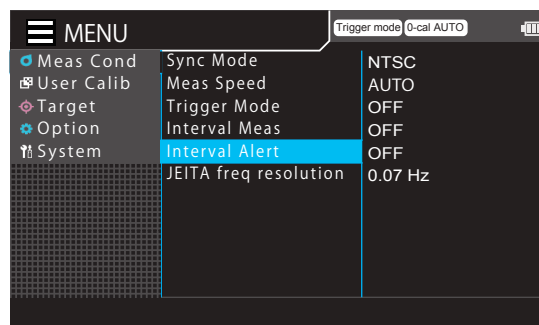
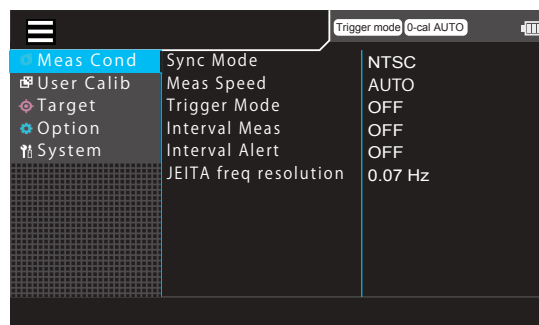

## Setting the Interval Alert

### 6 Press the [UP] or [DOWN] key and the [RIGHT]/[LEFT] keys to set a threshold, move to [Complete], and then press the [ENTER] key.

\* The threshold can be set to between 0.1 to 100.0%.

If the entered value is out of the available range, an alert screen is displayed. Press the [ENTER] key to return to the previous screen and reset the value.

Press the [ESC] key to cancel configuration of the setting and restore the original value.

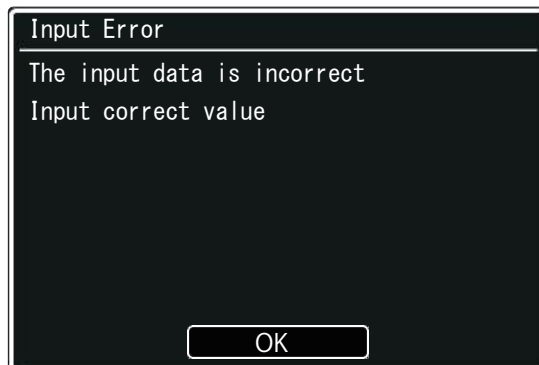
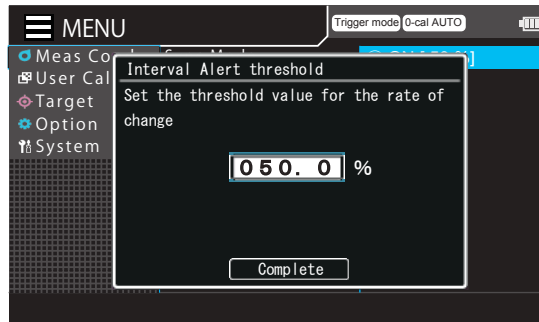

### 7 Press the [ESC] key twice.

The measurement screen is displayed on the LCD screen.

The interval alert setting and value will be kept even if the POWER switch is set to OFF (○).



# JEITA Freq Resolution Setting

[Meas Cond] - [JEITA freq resolution]

Set the frequency resolution for JEITA flicker measurements. The frequency can be set in units of 0.01 Hz, 0.1 Hz, or 1 Hz.

\* Factory setting: 1 Hz

## Operating Procedure

- 1 While the measurement screen is displayed, press the [MENU] key.**  
The setting screen is displayed on the LCD screen.
- 2 Press the [UP] or [DOWN] key to select [Meas Cond], and then press the [RIGHT] or [ENTER] key.**

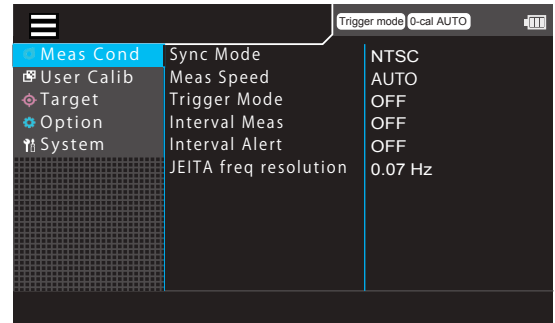

- 3 Press the [UP] or [DOWN] key to select [JEITA freq resolution], and then press the [ENTER] key.**

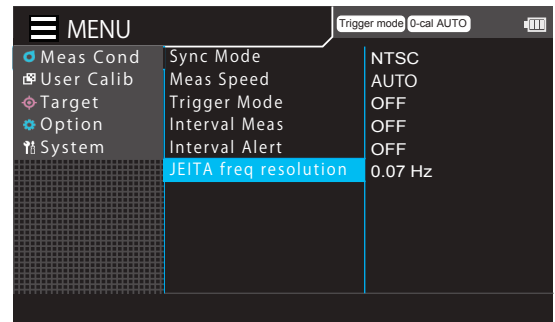

- 4 The screen for selecting a frequency setting range is displayed. Press the [UP] or [DOWN] key to select [Unit 0.01 Hz], [Unit 0.1 Hz], or [Unit 1 Hz], and then press the [ENTER] key.**

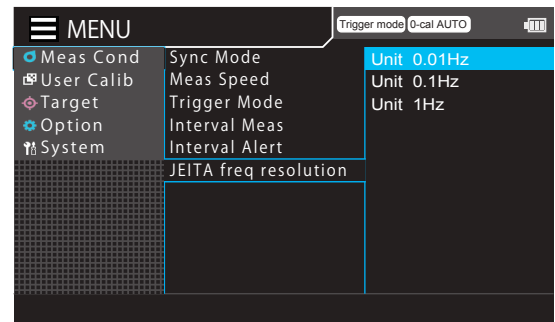

- 5 Press the [UP] or [DOWN] key and the [RIGHT]/[LEFT] keys to set a value, move to [Complete], and then press the [ENTER] key.**

\* The frequency can be set to between 0.07 to 10 Hz.

If the entered value is out of the available range, an alert screen is displayed. Press the [ENTER] key to return to the previous screen and reset the value.

Press the [ESC] key to cancel configuration of the setting and restore the original value.

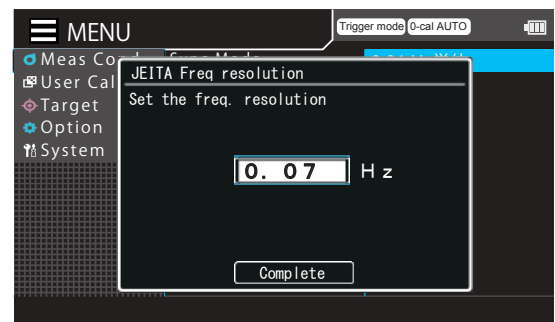

CA-DP40

Measurement Preparation

**6**

**Press the [ESC] key twice.**

The measurement screen is displayed on the LCD screen.

The JEITA freq resolution setting will be kept even if the POWER switch is set to OFF (○).

# Selecting a Probe No.

Measurement will be performed simultaneously using all connected probes.  
Follow the procedure given below to select the probe connector No. (P1 to P10) to which the desired probe is connected.

In this example, probes are connected to probe connectors [P1], [P3], and [P5].

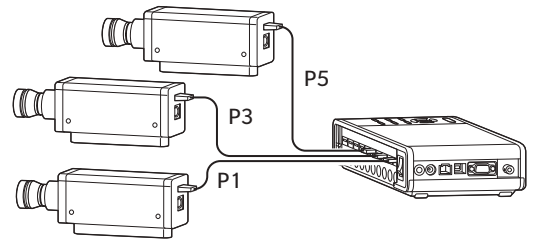

## How to Select

**On the measurement screen, press the [UP] or [DOWN] key to display the probe No. to be selected.**

Each time the key is pressed, the probe No. switches in the order of [P1] -> [P2] -> [P3].  
The probe information is displayed in the instrument information area.

\* By default, the number is set to [P1] when the POWER switch is set to ON (|).

# Calibration/Settings

This section explains settings that must be configured according to measurement method. The setting method varies according to the measurement method.

## From the Measurement Preparation section

<b>Outline of the Calibration/Settings Section</b> Explains measurement method types and settings that must be configured. (Check which settings must be configured.)	P. 67
--	-------

<b>Before Configuring Each Setting</b> Gives detailed explanations on calibration channels common to each setting and target values.	P. 68
---	-------

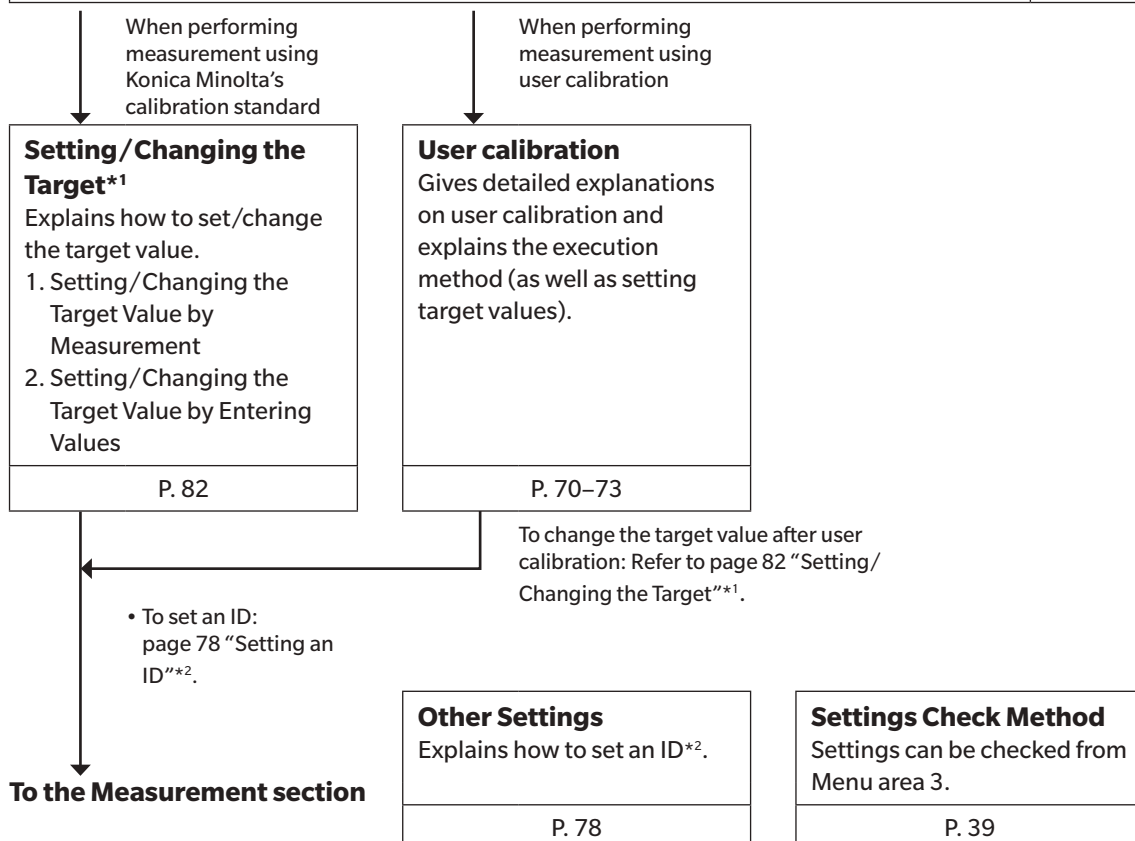

# Outline of the Calibration/Settings Section

This section explains settings that must be configured according to measurement method. Available measurement methods and the settings that must be made are explained below.

## 1. Measurement using Konica Minolta's Calibration Standard

With this method, measurement is performed using Konica Minolta's calibration standard without calibration. Even when setting the target value to calibration channel CH00, measurement must be performed as explained below. It is not necessary to set/change the target value if the color difference display function will not be used.

### Operating Procedure

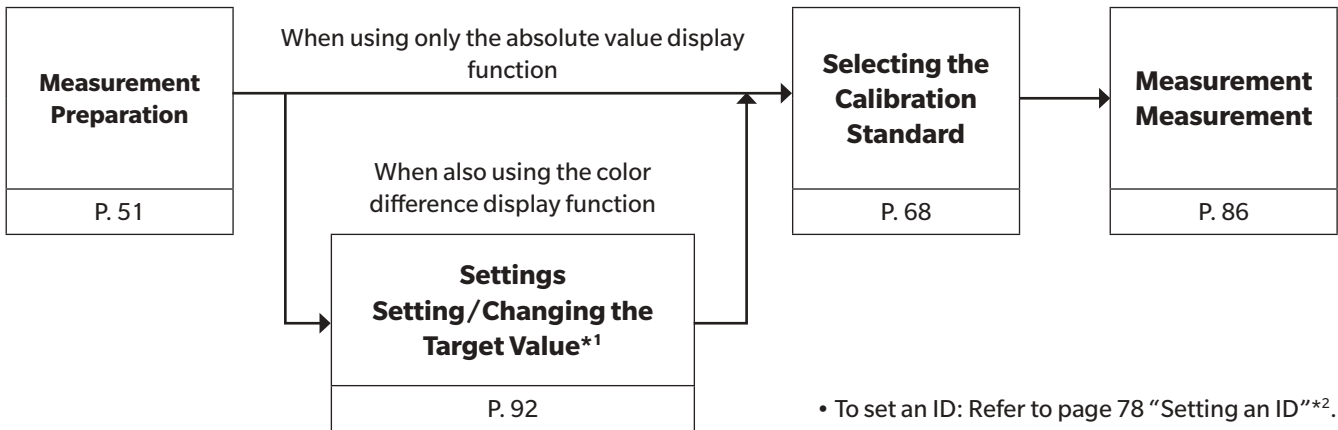

## 2. Measurement using user calibration

With this method, user calibration is performed and the obtained correction coefficient is used for measurement. Because the target value is also set, the color difference display section can show the deviation of the measured values from the target value. User calibration must be performed in the following cases. (However, it is not possible to perform user calibration using calibration channel CH00.)

- To correct variation of readings that occur due to the deviation of spectral sensitivity from the CIE 1931 color matching function
- To correct differences in readings between probes when two or more probes are used

### Operating Procedure

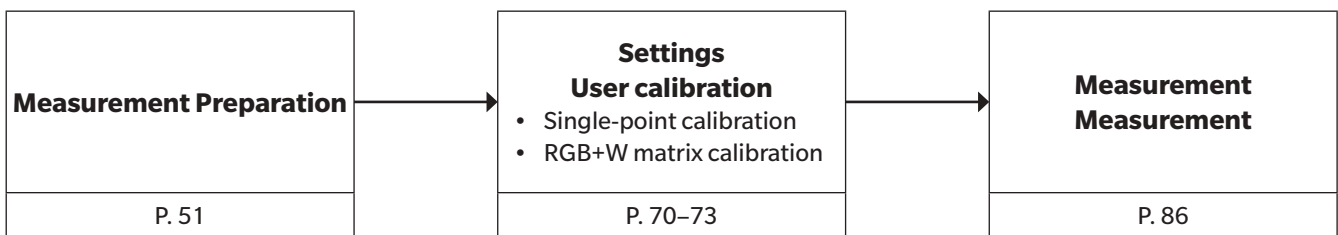

- User calibration details: Refer to page 70 "Performing User Calibration".
- To change the target after user calibration: Refer to page 82 "Setting/Changing the Target"\*1.
- To set an ID: Refer to page 78 "Setting an ID"\*2.

#### \*1 About "Setting/Changing the Target"

The following two methods can be used for setting/changing the target.

- (1) Setting/changing the target by measurement The display's measured values are set as the target.
- (2) Setting/changing the target by entering values Set the desired values (x, y, Lv) by entering them.

#### \*2 About "Setting an ID"

An ID is useful when specifying that the user calibration and target value have been set for a specific type of display with specific colors.

# Calibration

---

## 1. About Calibration Channels

---

A CA-410 Series probe has calibration channels from CH00 to CH99 (100 channels in total).

CH00 is a channel for measurement in accordance with Konica Minolta's calibration standard. The channel is preset with coefficients for Konica Minolta calibration, which cannot be changed by the user.

The following can be set for each channel between CH01 to CH99.

### **Correction coefficient for user calibration**

In one calibration channel, the correction coefficients for user calibration are used in common for each measurement mode ( $L_v x y$ ,  $L_v u'v'$ ,  $L_v T_{cp} duv$ ,  $X Y Z$ , and Dominant wavelength).

# About User Calibration

---

User calibration allows users to set their own correction coefficients to calibration channels of the instrument by setting calibration values ( $L_v x y$ ,  $L_v u'v'$ , or  $X Y Z$ ) on the instrument. Afterward, the value corrected with the specified correction coefficients will be displayed/output for every measurement.

User calibration can be performed to apply the following corrections to measurements based on the specified correction coefficients.

- (1) Correction of variation of readings that occur due to the deviation of spectral sensitivity from the CIE 1931 color-matching function
- (2) Correction of difference in readings between instruments when two or more instruments are used

Single-point calibration or RGB+W matrix calibration can be selected for user calibration. User calibration ensures accurate measurement of luminance and chromaticity near the calibration light source.

- When obtaining the calibration value by measuring the calibration light source with a measurement reference device, be sure to set the reference device and the instrument at the same position and angle from the calibration light source and measure the same measuring area. The instrument may not be calibrated properly if the measurement conditions are different from those of the reference device.
- During measurement, use a constant-voltage power supply for illuminating the calibration light source to ensure conditions are as stable as possible.

User calibration can be performed for every calibration channel except for CH00.

User calibration can be performed through the following methods.

- (1) By Measurement (Single-point calibration)..... P. 70
- (2) By Measurement (RGB+W matrix calibration)..... P. 72
- (3) Selecting from Saved Data..... P. 74
- (4) By inputting edit correction coefficients ..... P. 76

User calibration cannot be performed for calibration channel CH00.

(CH00 is a calibration channel for performing measurement in accordance with Konica Minolta's calibration standard.)

The user calibration correction coefficients are used in common for each color mode ( $L_v x y$ ,  $L_v u'v'$ ,  $L_v T_{cp} duv$ ,  $X Y Z$ , and Dominant wavelength).

# Performing User Calibration

## 1. By Measurement (Single-point calibration)

### Operating Procedure

- 1 While the measurement screen is displayed, press the [MENU] key.**  
The setting screen is displayed on the LCD screen.
- 2 Press the [UP] or [DOWN] key to select [User Calib], and then press the [RIGHT] or [ENTER] key.**
- 3 Press the [UP] or [DOWN] key to select [Measure and Register], and then press the [RIGHT] or [ENTER] key.**
- 4 The screen for selecting a probe is displayed. Press the [UP] or [DOWN] key to select the probe to register, and then press the [RIGHT] or [ENTER] key.**
- 5 The screen for selecting a calibration channel is displayed. Press the [UP] or [DOWN] key to select the channel to register.**
- 6 The screen for selecting a calibration type is displayed. Press the [UP] or [DOWN] key to select [Single-point calibration], and then press the [ENTER] key.**

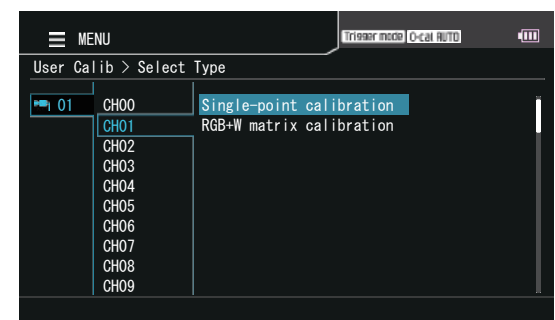
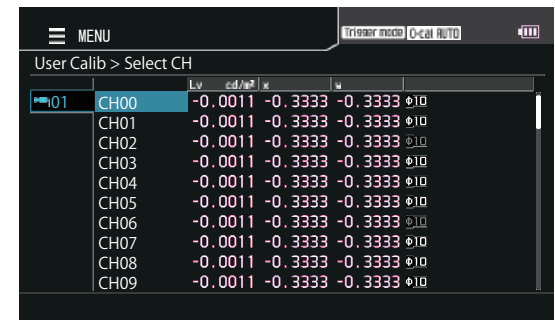
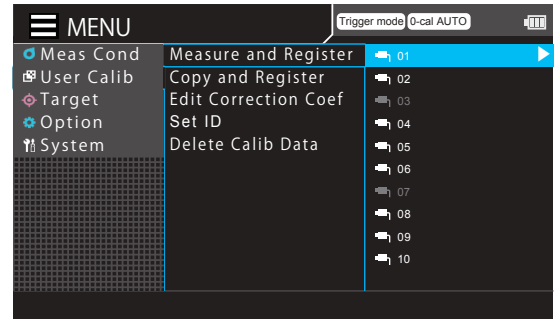
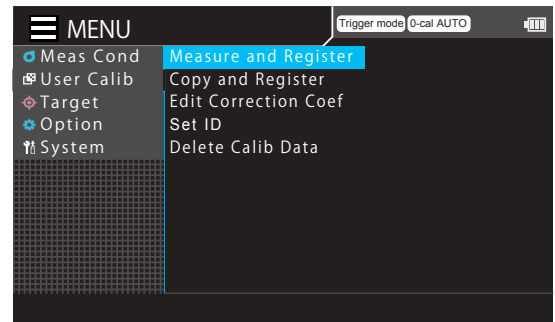
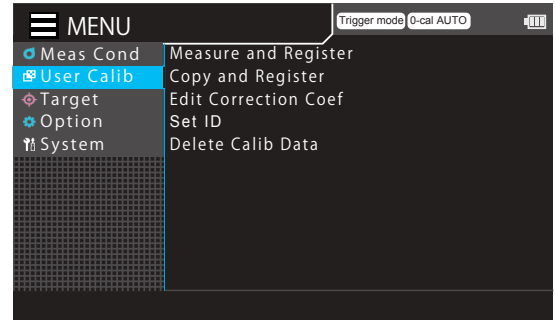



**7** When the pop-up screen for single-point calibration is displayed, press the [ENTER] key to perform measurement. When the measured value is displayed, press the [ENTER] key to hold the value.

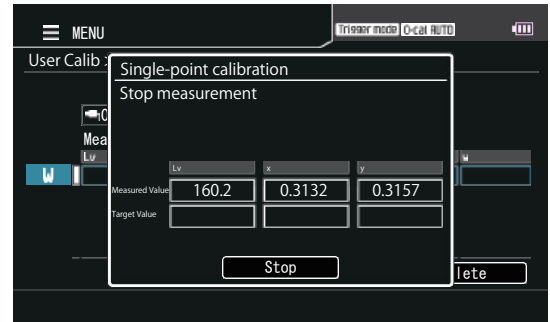
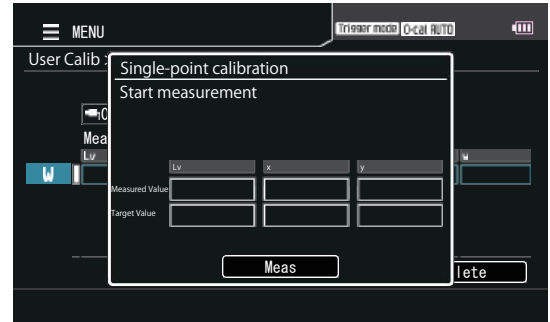

**8** Press the [UP] or [DOWN] key and the [RIGHT]/[LEFT] keys to select the field of a calibration value for user calibration, and then press the [ENTER] key.

**9** Press the [UP] or [DOWN] key and the [RIGHT]/[LEFT] keys to set a calibration value, and then press the [ENTER] key.

Press the [ESC] key to cancel configuration of the setting and restore the original value.

**10** Repeat steps 8 and 9 to set the calibration value, move to [Complete], and then press the [ENTER] key to confirm your entry.

(If the entered value is out of the available setting range, the screen returns to the value entry screen. Enter another value.)

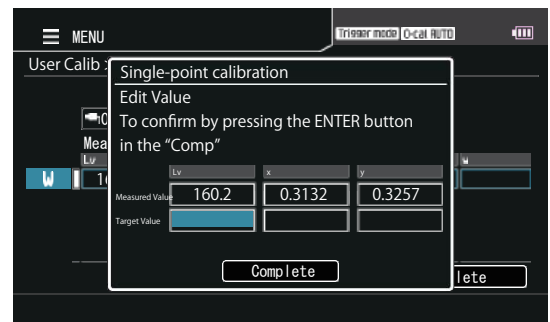
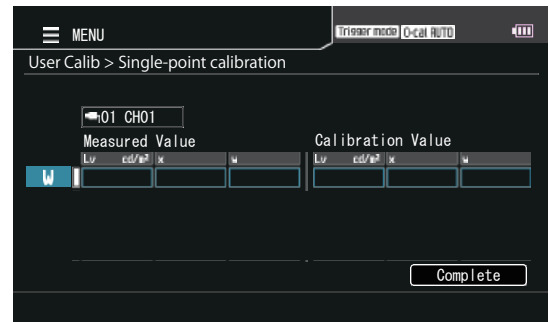

**11** Press the [ESC] key.

The measurement screen is displayed on the LCD screen.

The specified values will be kept even if the POWER switch is set to OFF (○).

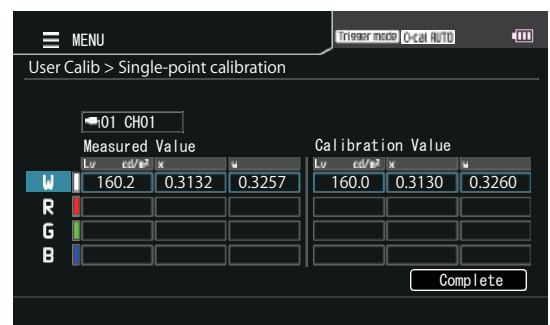

## 2. By Measurement (RGB+W matrix calibration)

### Operating Procedure

- 1** While the measurement screen is displayed, press the [MENU] key.  
The setting screen is displayed on the LCD screen.
- 2** Press the [UP] or [DOWN] key to select [User Calib], and then press the [RIGHT] or [ENTER] key.
- 3** Press the [UP] or [DOWN] key to select [Measure and Register], and then press the [RIGHT] or [ENTER] key.
- 4** The screen for selecting a probe is displayed. Press the [UP] or [DOWN] key to select the probe to register, and then press the [RIGHT] or [ENTER] key.
- 5** The screen for selecting a calibration channel is displayed. Press the [UP] or [DOWN] key to select the channel to register.
- 6** The screen for selecting a calibration type is displayed. Press the [UP] or [DOWN] key to select [RGB+W matrix calibration] and then press the [ENTER] key.

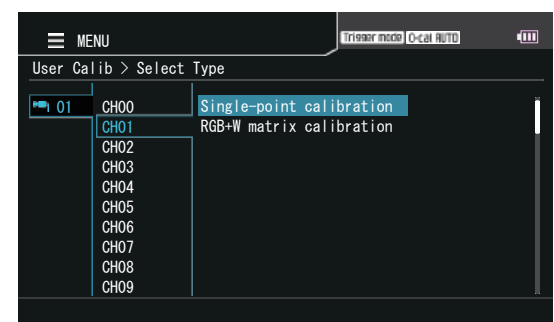
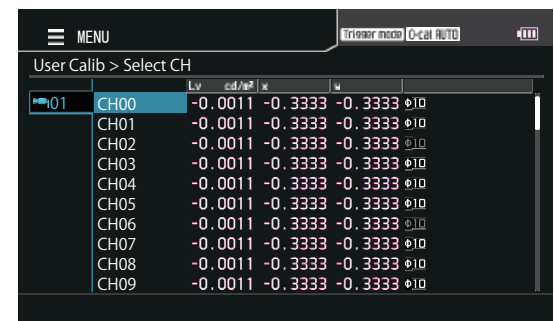
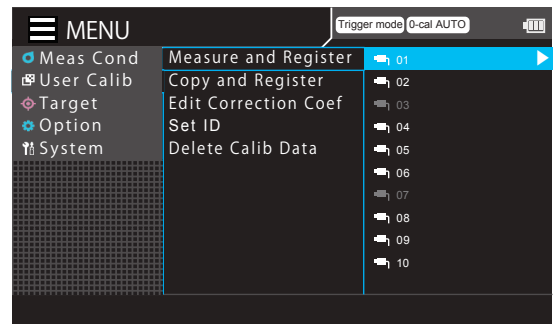
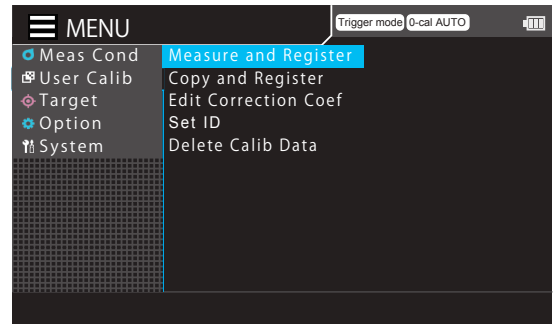
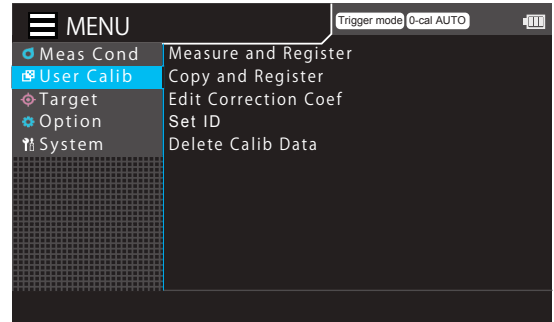

**7** The screen for selecting a color is displayed. Press the [UP] or [DOWN] key to select the color to measure and then press the [ENTER] key.

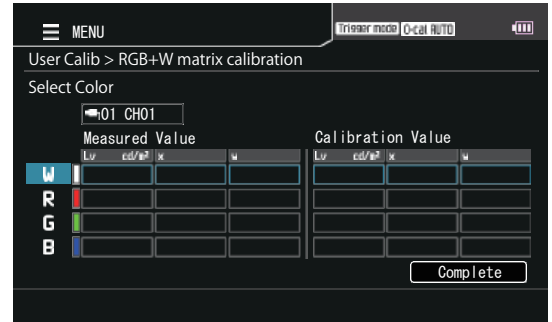

**8** When the pop-up screen for RGB+W matrix calibration is displayed, press the [ENTER] key to perform measurement. When the measured value is displayed, press the [ENTER] key to hold the value.

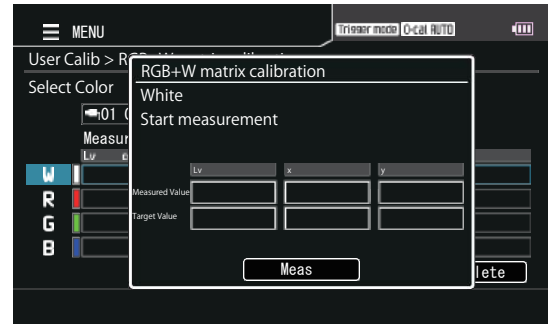

**9** Press the [UP] or [DOWN] key and the [RIGHT]/[LEFT] keys to select the field of a calibration value for user calibration, and then press the [ENTER] key.

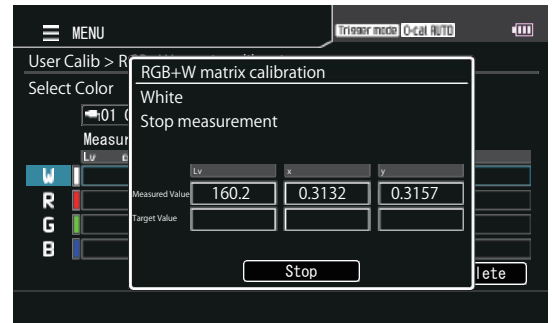

**10** Press the [UP] or [DOWN] key and the [RIGHT]/[LEFT] keys to set a calibration value, and then press the [ENTER] key. Press the [ESC] key to cancel configuration of the setting and restore the original value.

**11** Repeat steps 9 and 10 to set the calibration value, move to [Complete], and then press the [ENTER] key to confirm your entry.

**12** Repeat steps 7 to 11 to set calibration values for W, R, G, and B, move to [Complete], and then press the [ENTER] key to confirm your entry. (If the entered value is out of the available setting range, the screen returns to the value entry screen. Enter another value.)

**13** Press the [ESC] key. The measurement screen is displayed on the LCD screen. The specified values will be kept even if the POWER switch is set to OFF (O).

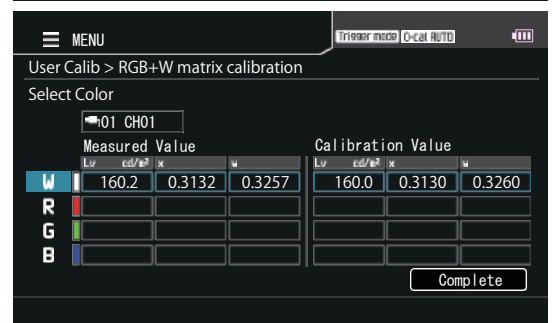
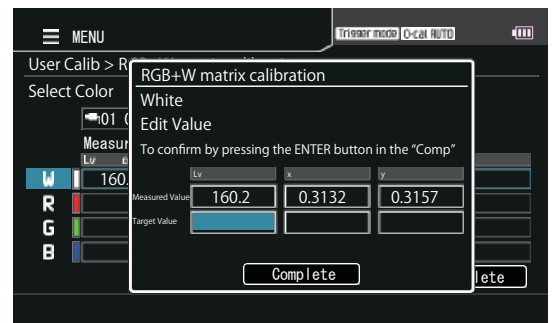

### 3. By selecting from saved data

**Operating Procedure**

**1** While the measurement screen is displayed, press the [MENU] key. The setting screen is displayed on the LCD screen.

**2** Press the [UP] or [DOWN] key to select [User Calib], and then press the [RIGHT] or [ENTER] key.

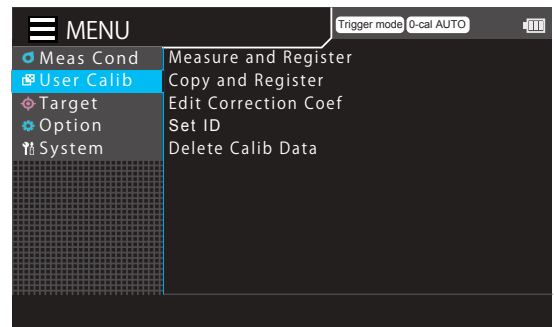

**3** Press the [UP] or [DOWN] key to select [Copy and Register], and then press the [RIGHT] or [ENTER] key.

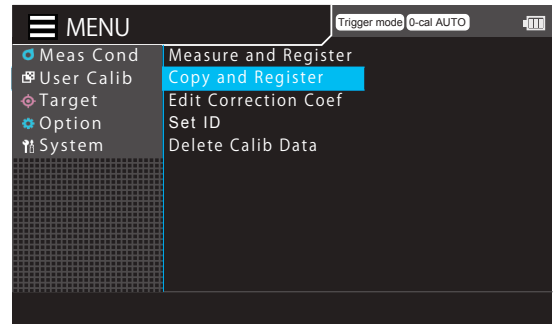

**4** The screen for selecting a probe is displayed. Press the [UP] or [DOWN] key to select the probe to register, and then press the [RIGHT] or [ENTER] key.

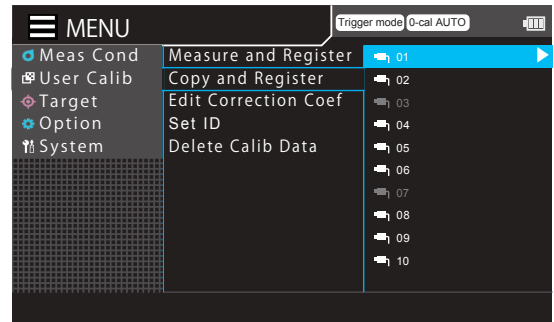

**5** The screen for selecting a calibration channel is displayed. Press the [UP] or [DOWN] key to select the channel to register.

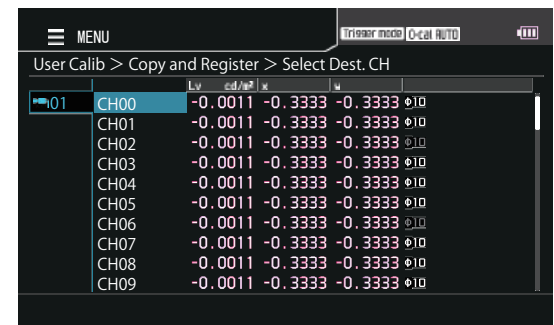

**6** Press the [ENTER] key.

---

**7****Select saved data.**

The screen for selecting a probe is displayed. Press the [UP] or [DOWN] key to select the probe with the information to use, and then press the [RIGHT] or [ENTER] key.

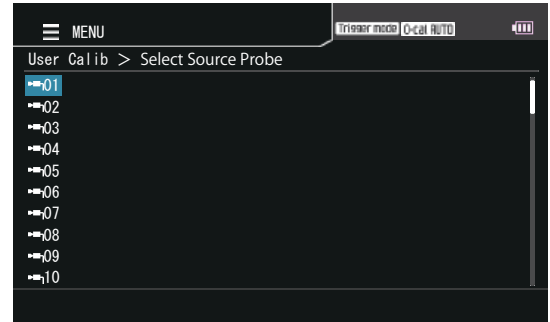
**8**

**The screen for selecting a calibration channel is displayed. Press the [UP] or [DOWN] key to select the channel to use.**

**9**

**Press the [ENTER] key to return to the menu screen.**

The specified values will be kept even if the POWER switch is set to OFF (○).

## 4. By inputting correction coefficients

### Operating Procedure

**1** While the measurement screen is displayed, press the [MENU] key.  
The setting screen is displayed on the LCD screen.

**2** Press the [UP] or [DOWN] key to select [User Calib], and then press the [RIGHT] or [ENTER] key.

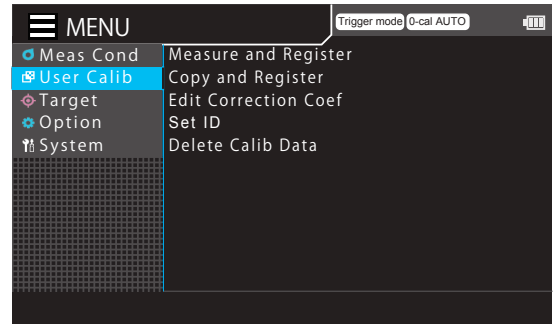

**3** Press the [UP] or [DOWN] key to select [Edit Correction Coef], and then press the [RIGHT] or [ENTER] key.

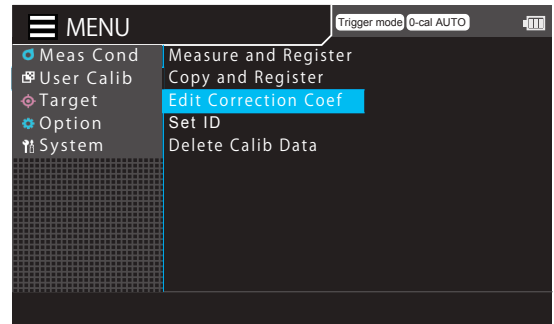

**4** The screen for selecting a probe is displayed. Press the [UP] or [DOWN] key to select the probe to register, and then press the [RIGHT] or [ENTER] key.

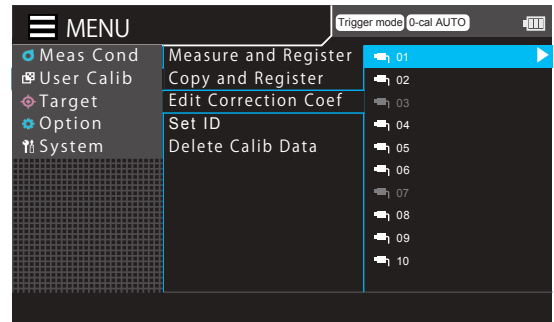

**5** The screen for selecting a calibration channel is displayed. Press the [UP] or [DOWN] key to select the channel to register.  
This screen allows the current data to be checked.

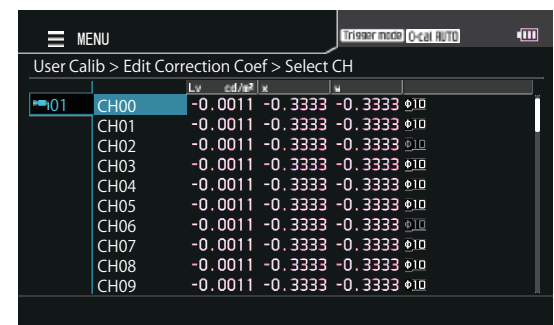

**6** Press the [ENTER] key.  
The screen for inputting correction coefficients is displayed.

**7** Press the [UP] or [DOWN] key and the [RIGHT]/[LEFT] key to set values, and then press the [ENTER] key.

**8** Move to [Complete] on the confirmation screen and press the [ENTER] key to return to the menu screen.

(The correction coefficient can be set to between 0.00001 to 9999999. If the entered value is out of the available setting range, the screen returns to the value entry screen. Enter another value.)

**9** Press the [ESC] key.

The measurement screen is displayed on the LCD screen.

The specified values will be kept even if the POWER switch is set to OFF (○).

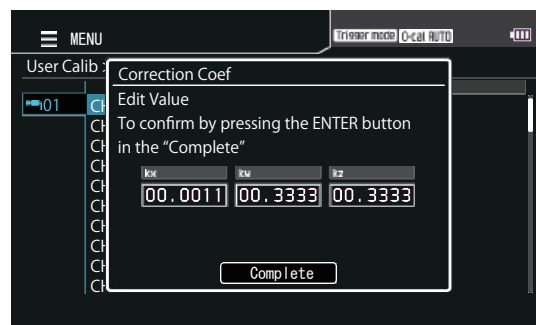

## 5. Setting an ID

Names can be applied to calibration channels.

**Memo** By default, the channel number is set as the name.

### Operating Procedure

- 1** While the measurement screen is displayed, press the [MENU] key.  
The setting screen is displayed on the LCD screen.
- 2** Press the [UP] or [DOWN] key to select [User Calib], and then press the [RIGHT] or [ENTER] key.
- 3** Press the [UP] or [DOWN] key to select [Set ID], and then press the [RIGHT] or [ENTER] key.
- 4** The screen for selecting a probe is displayed. Press the [UP] or [DOWN] key to select a probe and then press the [RIGHT] or [ENTER] key.
- 5** The screen for selecting a calibration channel is displayed. Press the [UP] or [DOWN] key to select a channel.

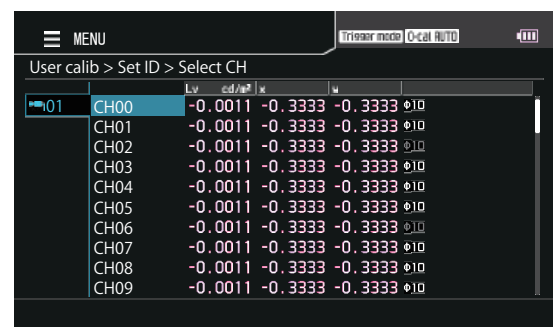
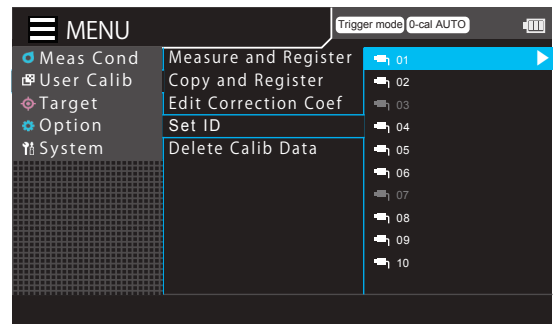
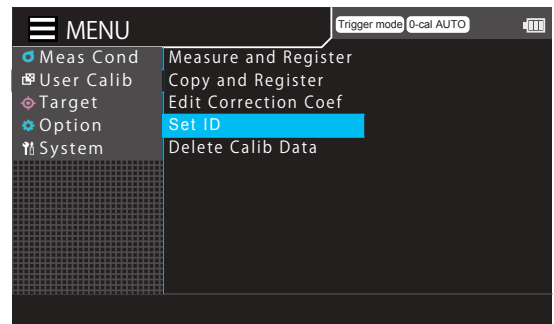
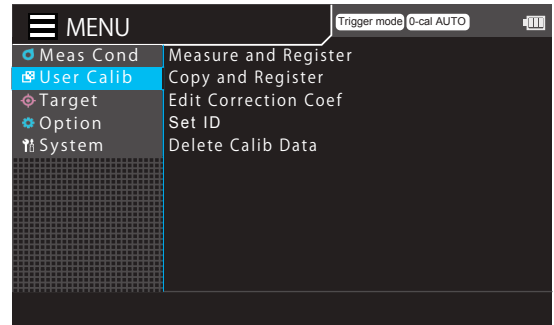



**6** Press the [ENTER] key to display the pop-up screen for inputting characters. Use the [▲]/[▼] or [◀]/[▶] keys to move the cursor to a target character, and then press the [ENTER] key.

- Input up to 10 characters.
- The selected character is displayed in the text box.



**7** Repeat step 6 to input the required number of characters.

- To delete the character on the left of the cursor in the text box, move the cursor to [✕] and press the [ENTER] key.

**8** When character input is completed, move the cursor to [OK] and press the [ENTER] key.

The setting is confirmed and the screen returns to calibration channel selection.

**Memo** Pressing the [ESC] key while configuring the settings will prevent the settings from being applied and cause the previous screen to reappear.

# Deleting Calibration Data

Follow the procedure below to delete saved values.

## Operating Procedure

- 1 While the measurement screen is displayed, press the [MENU] key.**  
The setting screen is displayed on the LCD screen.
- 2 Press the [UP] or [DOWN] key to select [User Calib], and then press the [RIGHT] or [ENTER] key.**
- 3 Press the [UP] or [DOWN] key to select [Delete Calib Data], and then press the [RIGHT] or [ENTER] key.**
- 4 The screen for selecting a probe is displayed. Press the [UP] or [DOWN] key to select the probe to register, and then press the [RIGHT] or [ENTER] key.**
- 5 The screen for selecting data to be deleted is displayed. Press the [UP] or [DOWN] key to select [All CH] or [Select CH], and then press the [RIGHT] or [ENTER] key.**

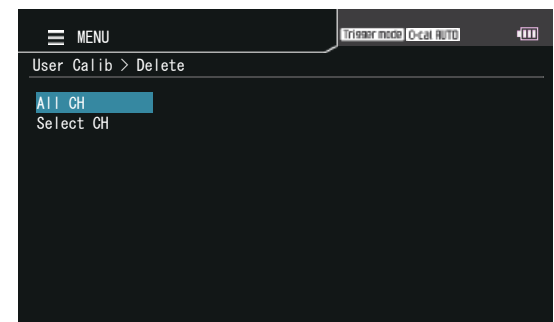
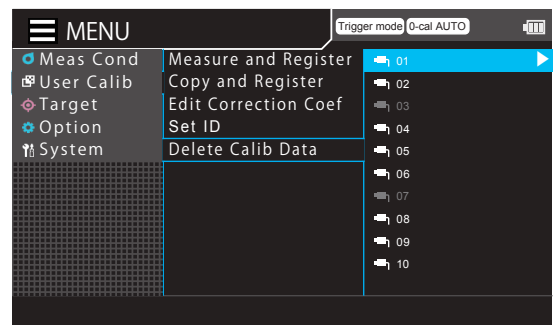
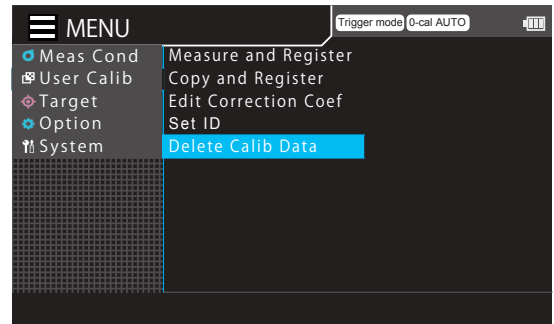
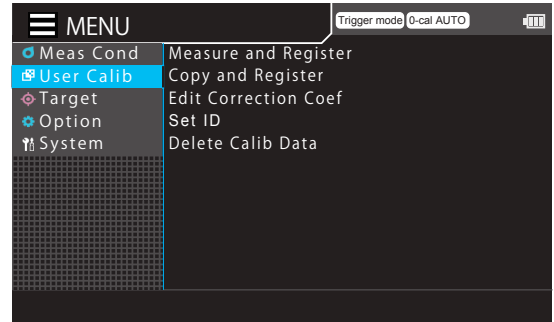

**6 -1** When selecting [All CH] and pressing the [ENTER] key, a delete confirmation message is displayed. Press the [RIGHT] or [LEFT] key to select [Yes] or [No], and then press the [ENTER] key to confirm the action.

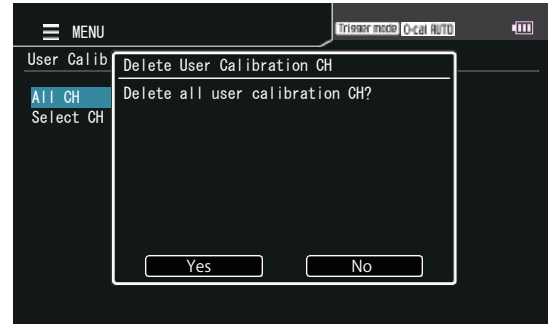

**6 -2** When selecting [Select CH], the screen for selecting a calibration channel is displayed. Press the [UP] or [DOWN] key to select the channel with data to delete.

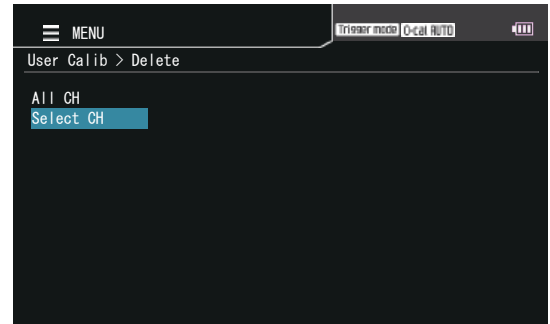

	CH	Lv	cd/m <sup>2</sup>	μ
01	CH00	-0.0011	-0.3333	-0.3333 010
	CH01	-0.0011	-0.3333	-0.3333 010
	CH02	-0.0011	-0.3333	-0.3333 010
	CH03	-0.0011	-0.3333	-0.3333 010
	CH04	-0.0011	-0.3333	-0.3333 010
	CH05	-0.0011	-0.3333	-0.3333 010
	CH06	-0.0011	-0.3333	-0.3333 010
	CH07	-0.0011	-0.3333	-0.3333 010
	CH08	-0.0011	-0.3333	-0.3333 010
	CH09	-0.0011	-0.3333	-0.3333 010

**7** When you press the [ENTER] key, a delete confirmation message is displayed. Press the [RIGHT] or [LEFT] key to select [Yes] or [No] and press the [ENTER] key to confirm the action.

**8** Press the [ESC] key twice. The measurement screen is displayed on the LCD screen.

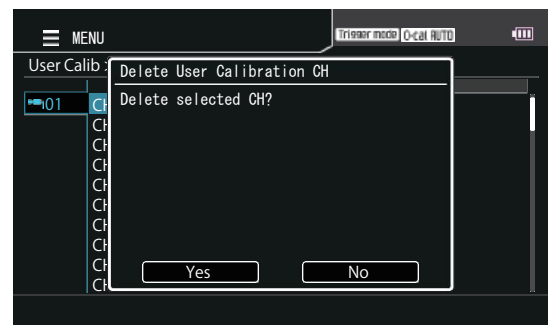

# Setting/Changing the Target

## 1. Target

A target is the value used as a reference to determine how much the measured value differs from it. Use one of the following methods to set a target.

- (1) By measurement and registration
- (2) By entering values

The target is used in common for each measurement mode (Lv x y, Lv u'v', Lv Tcp duv, X Y Z, and Dominant wavelength). By default, factory-set target values are preset in all channels.

## 2. By Measurement and Registration

### Operating Procedure

**1** While the measurement screen is displayed, press the [MENU] key. The setting screen is displayed on the LCD screen.

**2** Press the [UP] or [DOWN] key to select [Target], and then press the [RIGHT] or [ENTER] key.

**3** Press the [UP] or [DOWN] key to select [Measure and Register], and then press the [RIGHT] or [ENTER] key.

**4** The screen for selecting a probe is displayed. Press the [UP] or [DOWN] key to select the probe to register, and then press the [RIGHT] or [ENTER] key.

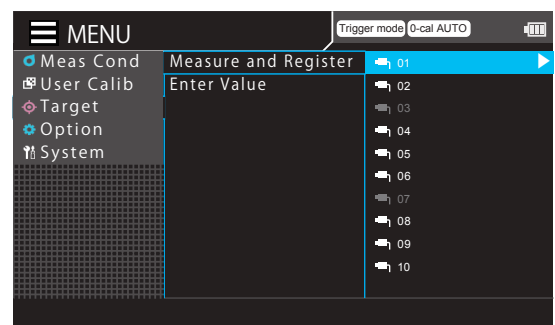

**5** The screen for selecting a calibration channel is displayed. Press the [UP] or [DOWN] key to select the channel to register. This screen allows the current data to be checked.

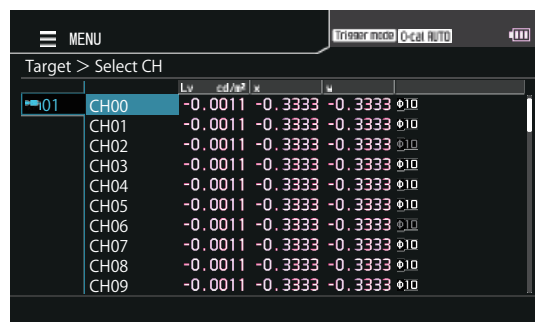

**6** Press the [ENTER] key. The pop-up screen for target value measurement is displayed with the “MEAS” button on it. Press the [ENTER] key again to perform measurement.

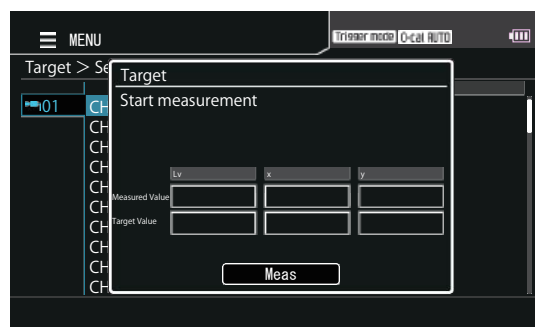

**7** When an appropriate target value is obtained, press the [ENTER] key to hold the value.

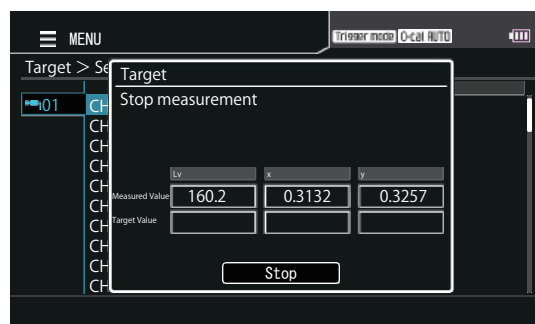

**8** Press the [UP] or [DOWN] key and the [RIGHT]/[LEFT] keys to select the field of a target, and then press the [ENTER] key.

**9** Press the [UP] or [DOWN] key and the [RIGHT]/[LEFT] keys to set a target value, and then press the [ENTER] key. (Press the [ESC] key to cancel configuration of the setting and restore the original value.)

**10** Repeat steps 8 and 9 to set target values, move to [Complete], and then press the [ENTER] key to confirm your entry. (If the entered value is out of the available setting range, the screen returns to the value entry screen. Enter another value.)

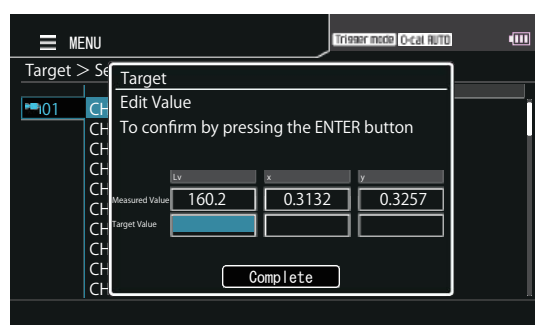

**11** Press the [ESC] key. The measurement screen is displayed on the LCD screen. The specified values will be kept even if the POWER switch is set to OFF (○).

### 3. By Entering Values

**Operating Procedure**

**1** While the measurement screen is displayed, press the [MENU] key.  
The setting screen is displayed on the LCD screen.

**2** Press the [UP] or [DOWN] key to select [Target], and then press the [RIGHT] or [ENTER] key.



**3** Press the [UP] or [DOWN] key to select [Enter Value], and then press the [RIGHT] or [ENTER] key.



**4** The screen for selecting a probe is displayed. Press the [UP] or [DOWN] key to select the probe to register, and then press the [RIGHT] or [ENTER] key.

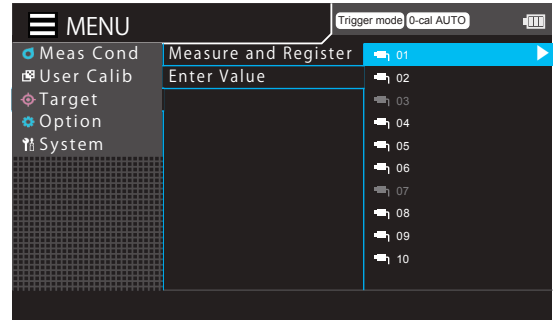

**5** The screen for selecting a calibration channel is displayed. Press the [UP] or [DOWN] key to select the target value to register.

This screen allows the current data to be checked.

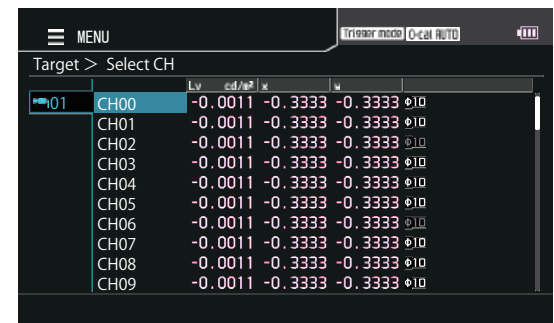

**6** Press the [ENTER] key.  
The screen for entering a target is displayed.

**7** Press the [UP] or [DOWN] key and the [RIGHT]/[LEFT] keys to select the value to set, and then press the [ENTER] key.

**8** Press the [UP] or [DOWN] key and the [RIGHT]/[LEFT] key to set values, and then press the [ENTER] key.

**9** Repeat steps 7 and 8. After setting is completed, press the [UP] or [DOWN] key to select the [Complete] button, and then press the [ENTER] key.

(If the entered value is out of the available setting range, the screen returns to the value entry screen. Enter another value.)

**10** Press the [ESC] key.

The measurement screen is displayed on the LCD screen.

The specified values will be kept even if the POWER switch is set to OFF (○).

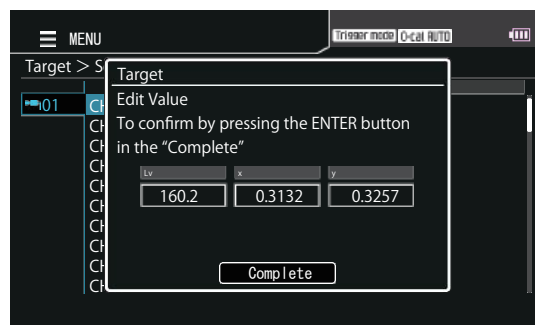

# Measurement

This section explains measuring methods.

## From the Settings section



<b>Measurement</b> Explains measuring methods, how to hold the measured values, how to read them, and how to clear them.	P. 87
---	-------



# Measurement

Before starting measurement, perform the following.

<b>Connection</b> (P. 44)	Connect the power cable and turn ON the power.
<b>Measurement Preparation</b> (P. 51)	Perform preparations (instrument setting, zero calibration) that are required prior to measurement.
<b>Settings</b> (P. 92)	Set up the instrument according to the setting method. This is not necessary if the instrument has already been set up or if measurement will be performed using Konica Minolta's calibration standard.

## 1. Performing Measurement

### Operating Procedure

#### 1 Press the [CAL CH] key to select a probe and a calibration channel. (Not required in flicker mode)

(1) Press the [CAL CH] key.

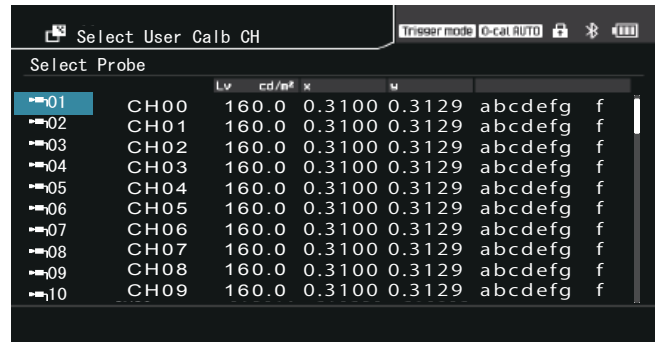

(2) Press the [UP]/[DOWN] key to select a probe (01 to 10) and then press the [ENTER] key.

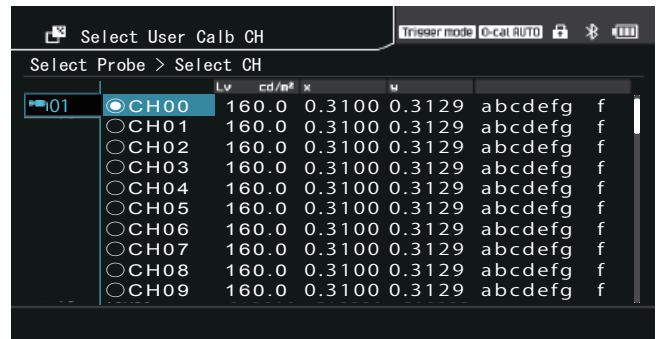

		Calibration Value
f	KM factory calibration value	"----"
c	User calibration (with set correction coefficients)	"----"
s	Single-point calibration	Single-point calibration value
m	RGB+W matrix calibration	White calibration value

(3) Press the [UP]/[DOWN] key to select a calibration channel (CH00 to 99), and then press the [ENTER] key.

The calibration coefficient for the selected calibration channel is applied.

#### 2 Place the probe flat against the display and perform measurement.

The measurement results will be displayed in the selected data display area.

### Notes on Measurement

- Because the luminance of the display is unstable for a while immediately after the display has been turned ON, the measured values must be read after they have stabilized.
- Static electricity on the display's screen surface must be removed as much as possible.
- Perform zero calibration if the ambient temperature has changed.
- Make sure that the probe is placed straight against the display. If it is tilted or moved, accurate measurement cannot be performed.
- Take care not to let the probe be exposed to excessive impact. In addition, do not pull or bend the cord excessively or exert excessive force on it. Failure to observe these cautions may result in breakdown or wire-breakage.
- A probe for which user calibration has been performed using a display with the same characteristics as the display to be measured is required.
- If an incorrect vertical synchronization frequency is set in INT mode, correct measured values will not be obtained.
- If two or more probes are connected, measurement will be performed simultaneously using all of the probes.

## 2. Holding the Measured Values

---

### To hold the measured values, press the [HOLD] key.

The status in the status display area changes to "Hold".

Pressing the [HOLD] key again will cancel hold mode and resume measurement. This will change the status display in the status display area to "Measuring".

\* If the color mode is changed in a hold state, the measured values that are currently held will be re-calculated according to the new conditions and then displayed.

\* Measured values can be saved in a hold state. Refer to page 32 for information on saving data.

### Notes on Holding Measured Values

- It is not possible to hold the measured values in the following cases.
  - (1) Until the measured values appear after the POWER switch is set to ON (|).
  - (2) Until the measured values appear after the [0-CAL] key is pressed.
- To cancel hold mode, press the [0-CAL] key.

## 3. Displaying the Measured Values

---

### For xyLv, TduvLv, u'v'Lv, XYZ, or $\lambda$ dPe Mode

The measurement results are displayed in the measured value display section.

- The measured value display section shows the measured values.

The probe outputs measured values each time, and a connected data processor can be used to retrieve all of the values through communication. Generally, however, measured values are not displayed all at once but at an appropriate interval.

Refer to page 21 for measurement modes.
- The range to be displayed for TduvLv mode is as follows.
$$2300 \leq T \leq 20000 \text{ (K)}$$
$$| \text{duv} | < 0.1$$

### For Flicker Mode

Flicker mode is a function that can be used only when a  $\varnothing$ 27 Probe (CA-P427), a  $\varnothing$ 27 probe for high luminance (CA-P427H), a  $\varnothing$ 10 probe /  $\varnothing$ 10 mini probe (CA-P410/MP410), or a  $\varnothing$ 10 probe for high luminance /  $\varnothing$ 10 mini probe for high luminance (CA-P410H/MP410H) is connected.

In flicker mode with a probe capable of flicker measurement connected, a selected probe cannot be changed to a  $\varnothing$ 27 high-sensitivity probe (CA-VP427), a  $\varnothing$ 2 small spot probe (CA-VP402), a  $\varnothing$ 4 small spot probe (CA-VP404), or a  $\varnothing$ 10 LWD probe (CA-VP410T).

- The range to be displayed for flicker mode is as follows.

0.0 to 999.9% (displays up to the first decimal place)

## Out of Measurement Range

Refer to P. 119 for information on error messages.

The measurement display section will show “-----” in the following cases.

Details	Countermeasure
The brightness of the measurement object exceeds the upper limit.	Lower the brightness of the measurement target.
Calculating the correlated color temperature or dominant wavelength of the measurement target is not possible with colorimetry.	Retry the measurement. If the situation does not improve, change the color mode to any mode other than Lv Tcp duv or Lv λd Pe.
The measurable range of the instrument is 999.9% for FMA flicker measurement, and it is exceeded.	Adjust the measurement target and retry the measurement after the flicker amount has decreased.
The vertical synchronization signal frequency is beyond the range that can be input to the instrument in FMA flicker measurement.	<p>Retry the measurement while taking into account the following.</p> <p><b>When measuring with EXT as the measurement frequency mode:</b></p> <p>(1) Make sure the BNC cable being used is properly connected, and input the vertical synchronization signal.</p> <p>(2) Check the frequency of the vertical synchronization signal being input. With FMA flicker measurement, the range of vertical synchronization signal frequency that can be input is between 0.50 and 130.00 Hz.</p> <p>(3) If inputting the appropriate vertical synchronization signal is difficult, change the measurement frequency mode to a mode other than EXT.</p> <p><b>When measuring with INT as the measurement frequency mode:</b></p> <p>(1) Check the set synchronization frequency. With FMA flicker measurement, the range of vertical synchronization signal frequency that can be input is between 0.50 and 130.00 Hz.</p> <p>(2) If setting an appropriate synchronization frequency is difficult, change the measurement frequency mode to a mode other than INT.</p>
A probe that is not capable of performing flicker measurement is being used for flicker measurement.	Note that ø27 high-sensitivity probe (CA-VP427), ø2 small spot probe (CA-VP402), ø4 small spot probe (CA-VP404), and ø10 LWD probe (CA-VP410T) are not capable of flicker measurement. To perform flicker measurement, please use a different probe.

## Aliasing Noise

During JEITA flicker measurement, when measuring a light source that includes a harmonic component such as a rectangular wave light source, aliasing noise may occur in the low-frequency range, which can be displayed as the JEITA flicker value. Peaks that vary greatly on the Power Spectrum graph when changing the JEITA frequency resolution setting by one step likely are being influenced by aliasing noise.

Set the sampling frequency for JEITA flicker measurement as follows (typical examples).

JEITA frequency resolution	Sampling frequency
0.1 Hz	204.8 Hz
0.5 Hz	256 Hz
1 Hz	256 Hz

## 4. Checking and Deleting Measurement Data

Press the [DATA] key to check or delete measurement data and interval logs.

### Operating Procedure

#### 1 Press the [DATA] key.

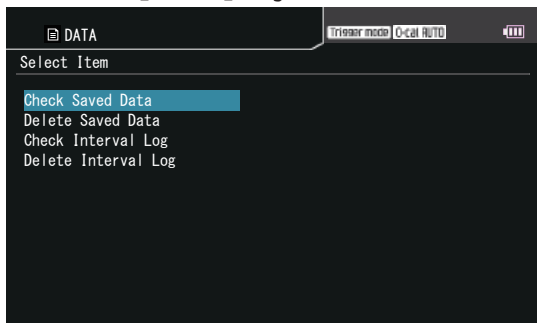

#### 2 Press the [UP]/[DOWN] key to select a menu, and then press the [ENTER] key.

##### Measurement data

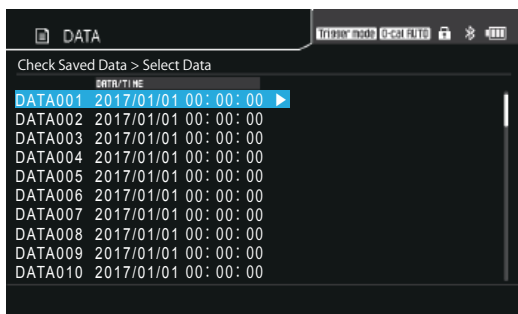

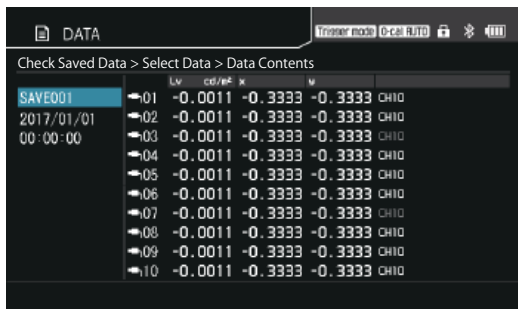
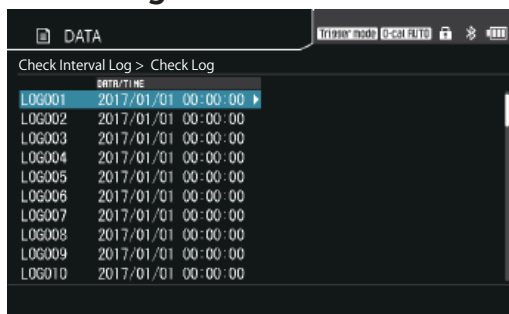

##### Interval logs

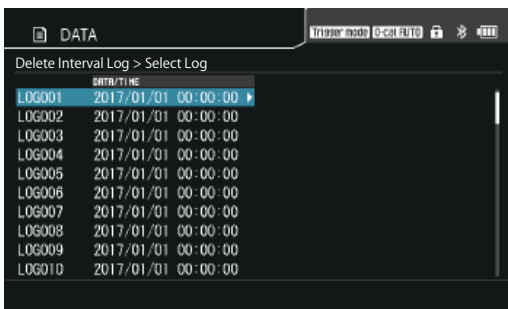
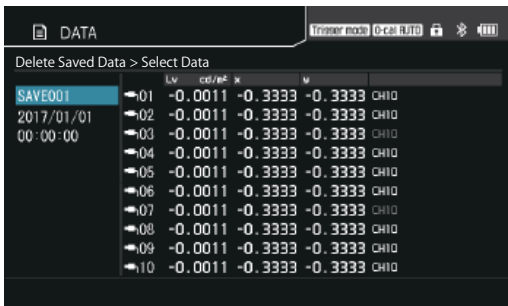
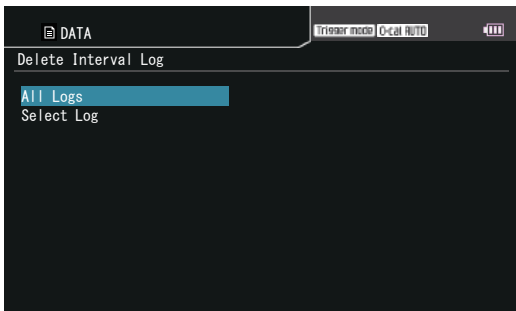
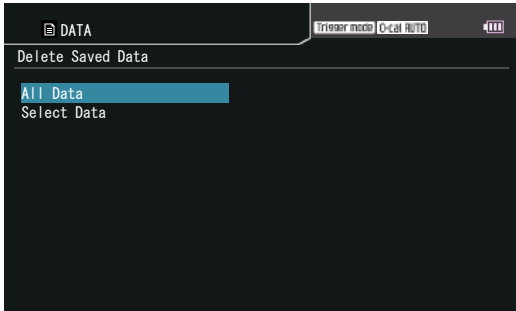

**3** Press the [UP]/[DOWN] key to select measurement data or interval log, and then press the [ENTER] key.



# Settings

The Settings section explains the settings that can be configured under [ Menu], [ Option], and [ System].

<b>Setting the Selectable Color Spaces .....</b>	<b>93</b>
<b>Selecting the Color Mode.....</b>	<b>94</b>
<b>Selecting the Absolute Value/Color Difference</b>	
<b>Display .....</b>	<b>95</b>
<b>Setting the Display Brightness.....</b>	<b>96</b>
<b>Setting Operation Sounds .....</b>	<b>97</b>
<b>Auto 0-Cal Settings .....</b>	<b>98</b>
<b>Save Destination Setting .....</b>	<b>99</b>
<b>Selecting Luminance Units .....</b>	<b>100</b>
<b>Setting the Power Save mode .....</b>	<b>101</b>
<b>Setting the Internal Clock.....</b>	<b>102</b>
<b>Setting the Date Format .....</b>	<b>103</b>
<b>Selecting the Display Language.....</b>	<b>104</b>
<b>Checking the Instrument Information.....</b>	<b>105</b>
<b>Initializing the Settings .....</b>	<b>106</b>

# Setting the Selectable Color Spaces

This instrument allows users to specify the color spaces that can be selected.

\* Factory setting: All options selected

## Operating Procedure



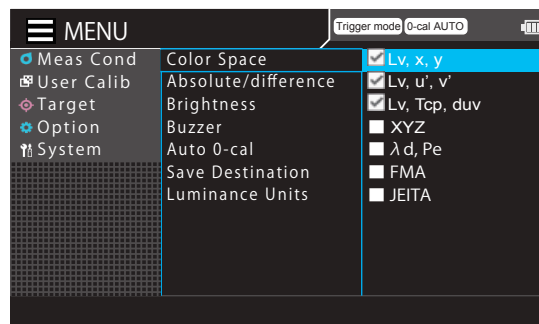
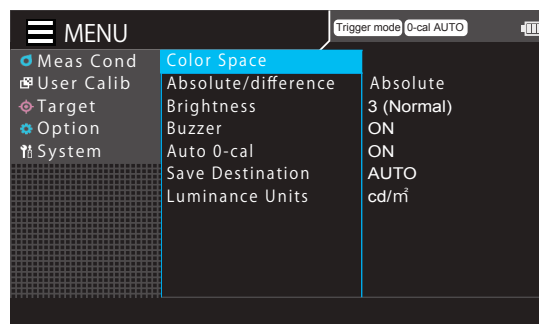
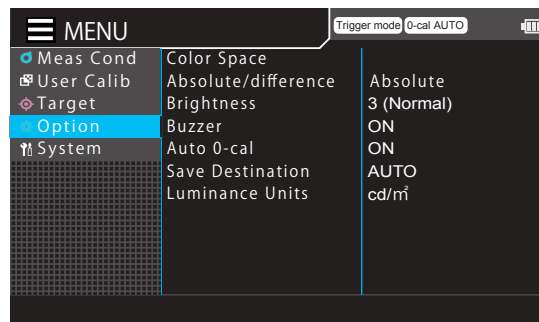



- 1 While the measurement screen is displayed, press the [MENU] key.**  
The setting screen is displayed on the LCD screen.
- 2 Press the [UP] or [DOWN] key to select [Option], and then press the [RIGHT] or [ENTER] key.**
- 3 Press the [UP] or [DOWN] key to select [Color Space], and then press the [ENTER] key.**
- 4 The screen for selecting a color space is displayed. Press the [UP] or [DOWN] key and the [ENTER] key to set whether an individual color space can be selected.**
- 5 Press the [ESC] key.**  
The measurement screen is displayed on the LCD screen.  
The selectable color space setting will be kept even if the POWER switch is set to OFF (○).



# Selecting the Color Mode

The following color modes are available.

\* Factory setting: Lvxy

Color Mode	LCD screen display	Description of mode
Lvxy		Mode for displaying and outputting luminance Lv and chromaticity coordinates x, y
Lvu'v'		Luminance Lv and u'v' chromaticity diagram (CIE 1976 UCS chromaticity diagram) Mode for displaying and outputting coordinates u' and v'
LvTcpduv		Mode for displaying and outputting luminance Lv, correlated color temperature Tcp, and color difference from blackbody locus duv
XYZ		Mode for displaying and outputting tristimulus values X, Y, Z
Dominant wavelength*1 Excitation purity		Mode for displaying and outputting luminance Lv, dominant wavelength λd, and excitation purity Pe
Flicker (Contrast)		Mode for displaying and outputting Contrast-method flicker
Flicker (JEITA)		Mode for displaying and outputting JEITA-method flicker

\* 1 When the measured value is a non-spectral color, the value of the complementary wavelength is displayed. In this case, the symbol is also λd but a minus sign is added.

## Operating Procedure

1

**On the measurement screen, press the [MODE] key to display a desired color mode.**

Each time the [MODE] key is pressed, the measurement screen display is cycled in the order of Lv x y -> Lv u'v' -> Lv Tcp duv -> X Y Z -> Lv λd Pe -> FMA -> JEITA -> Lv x y.

The color mode setting will be kept even if the POWER switch is set to OFF (○).



# Selecting the Absolute Value/Color Difference Display

Chromaticity measurement results can be displayed either as the absolute value or the difference.

\* Chromaticity display method: Absolute Value, Difference

\* Factory setting: Absolute Value

## Operating Procedure

- 1 While the measurement screen is displayed, press the [MENU] key.**  
The setting screen is displayed on the LCD screen.
- 2 Press the [UP] or [DOWN] key to select [Option], and then press the [RIGHT] or [ENTER] key.**
- 3 Press the [UP] or [DOWN] key to select [Absolute/Difference], and then press the [ENTER] key.**
- 4 The screen for selecting a display method is displayed. Press the [UP] or [DOWN] key to select [Absolute] or [Difference].**
- 5 Press the [ESC] key.**  
The measurement screen is displayed on the LCD screen.  
The display method setting will be kept even if the POWER switch is set to OFF (○).

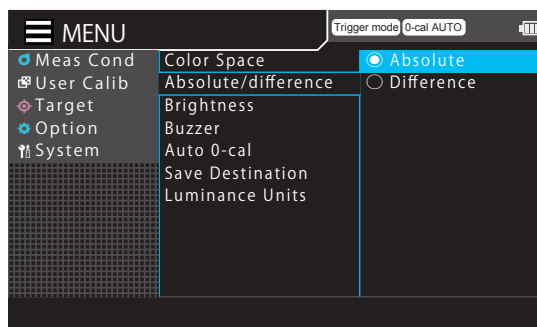
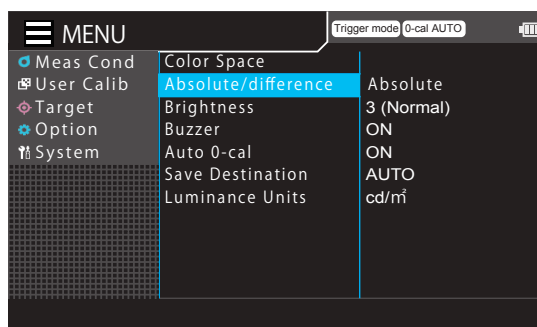
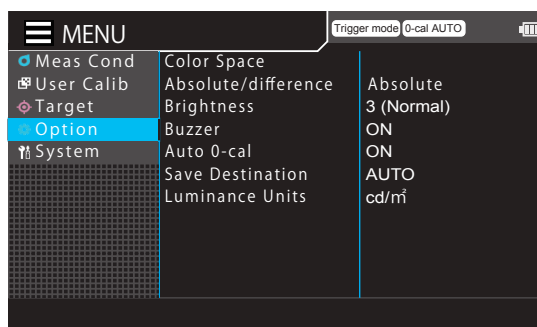

# Setting the Display Brightness

This instrument allows users to set the brightness of the external LCD screen.

\* Factory setting: 3 (Standard)

## Operating Procedure

**1 While the measurement screen is displayed, press the [MENU] key.**  
The setting screen is displayed on the LCD screen.

**2 Press the [UP] or [DOWN] key to select [Option], and then press the [RIGHT] or [ENTER] key.**

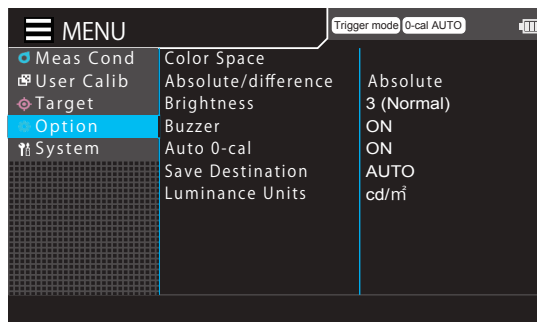

**3 Press the [UP] or [DOWN] key to select [Brightness], and then press the [ENTER] key.**

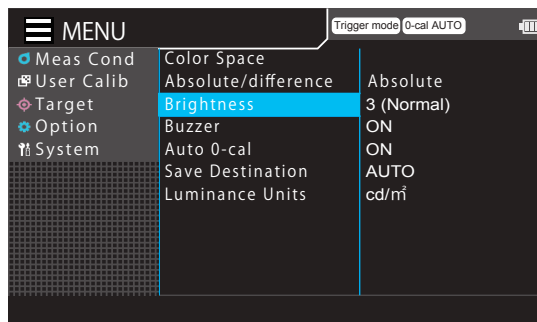

**4 The screen for selecting a brightness is displayed. Press the [UP] or [DOWN] key to select a brightness.**

**5 Press the [ESC] key.**  
The measurement screen is displayed on the LCD screen.  
The brightness setting will be kept even if the POWER switch is set to OFF (○).

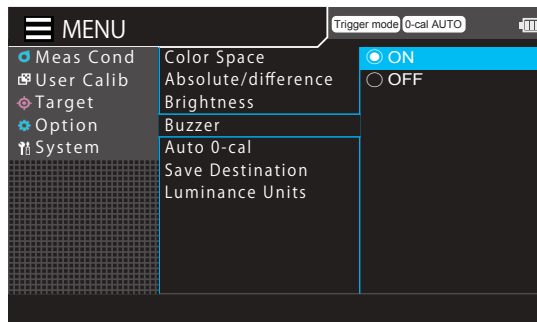

# Setting Operation Sounds

This instrument allows users to turn operation sounds ON or OFF.

\* Factory setting: ON

## Operating Procedure

- 1 While the measurement screen is displayed, press the [MENU] key.**  
The setting screen is displayed on the LCD screen.
- 2 Press the [UP] or [DOWN] key to select [Option], and then press the [RIGHT] or [ENTER] key.**
- 3 Press the [UP] or [DOWN] key to select [Buzzer], and then press the [ENTER] key.**
- 4 The screen for selecting ON or OFF is displayed. Press the [UP] or [DOWN] key to make a selection.**
- 5 Press the [ESC] key.**  
The measurement screen is displayed on the LCD screen.  
The operation sound setting will be kept even if the POWER switch is set to OFF (○).

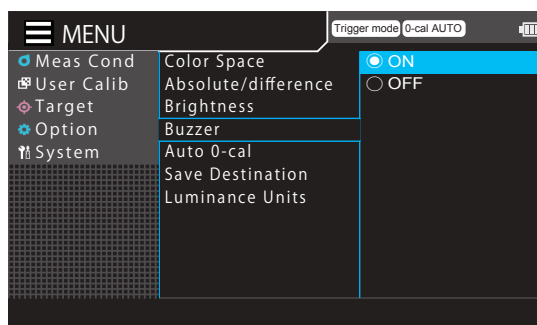
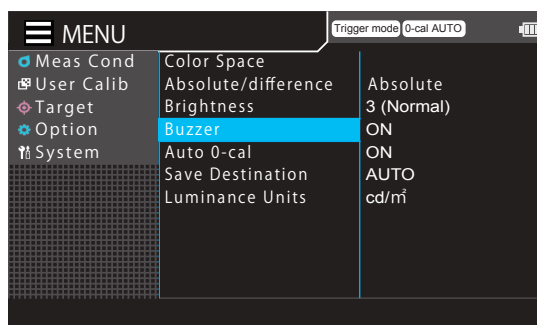
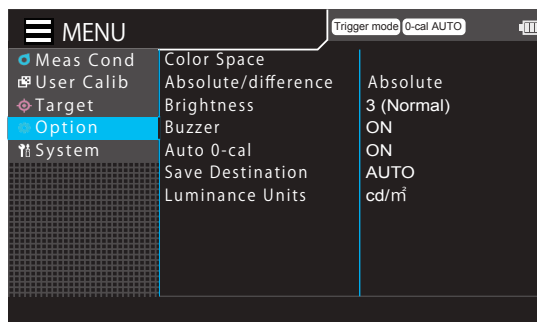

# Auto 0-Cal Settings

This instrument can be configured to perform zero calibration automatically.

When set to [ON], the shutter of the probe automatically closes and Auto 0-cal is performed if the probe temperature has changed 6°C. However, this function is disabled if interval measurement is performed with a measurement interval of 9 seconds or less.

\* Factory setting: OFF

## Operating Procedure

- 1 While the measurement screen is displayed, press the [MENU] key.**  
The setting screen is displayed on the LCD screen.
- 2 Press the [UP] or [DOWN] key to select [Option], and then press the [RIGHT] or [ENTER] key.**
- 3 Press the [UP] or [DOWN] key to select [Auto 0-cal], and then press the [ENTER] key.**
- 4 The screen for selecting whether to perform Auto 0-cal is displayed. Press the [UP] or [DOWN] key to select [ON] or [OFF]**  
.
- 5 Press the [ESC] key.**  
The measurement screen is displayed on the LCD screen.  
The Auto 0-cal setting will be kept even if the POWER switch is set to OFF (○).

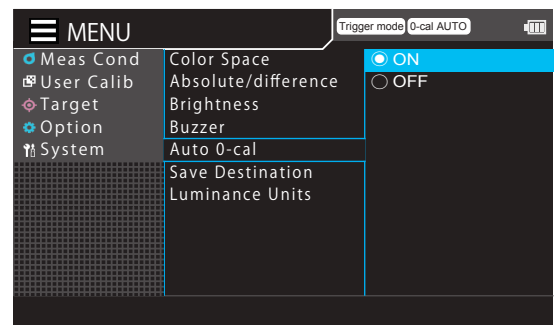
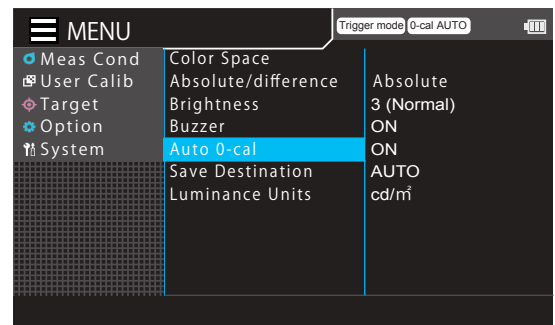
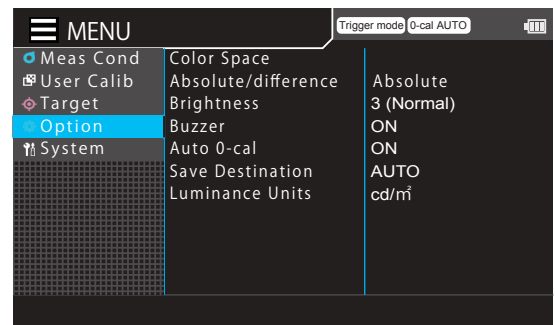

# Save Destination Setting

This instrument can be configured to select the destination to save measurement data automatically or manually.

\* Factory setting: AUTO

## Operating Procedure

- 1 While the measurement screen is displayed, press the [MENU] key.**  
The setting screen is displayed on the LCD screen.
- 2 Press the [UP] or [DOWN] key to select [Option], and then press the [RIGHT] or [ENTER] key.**
- 3 Press the [UP] or [DOWN] key to select [Save Destination], and then press the [ENTER] key.**
- 4 The screen for selecting [AUTO] or [MANUAL] is displayed. Press the [UP] or [DOWN] key to make a selection.**
- 5 Press the [ESC] key.**  
The measurement screen is displayed on the LCD screen.  
The Save Destination setting will be kept even if the POWER switch is set to OFF (○).

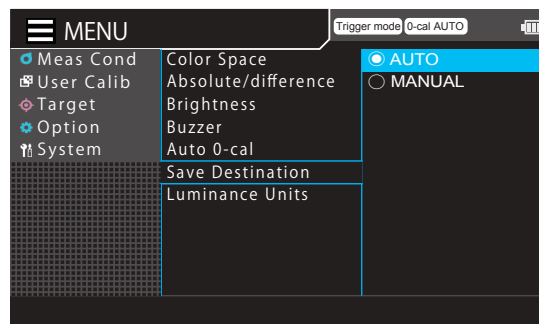
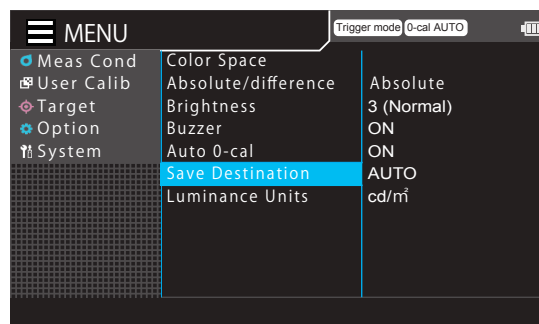
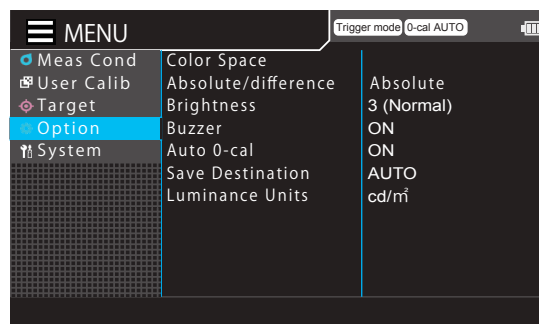

# Selecting Luminance Units

[Option] - [Luminance Units]

This instrument allows users to select the luminance units to be displayed.

\* Factory setting: cd/m<sup>2</sup>

## Operating Procedure

- 1 While the measurement screen is displayed, press the [MENU] key.**  
The setting screen is displayed on the LCD screen.
- 2 Press the [UP] or [DOWN] key to select [Option], and then press the [RIGHT] or [ENTER] key.**
- 3 Press the [UP] or [DOWN] key to select [Luminance Units], and then press the [ENTER] key.**
- 4 The screen for selecting luminance units is displayed. Press the [UP] or [DOWN] key to select [cd/m<sup>2</sup>] or [fL].**
- 5 Press the [ESC] key.**  
The measurement screen is displayed on the LCD screen.  
The luminance unit setting will be kept even if the POWER switch is set to OFF (○).

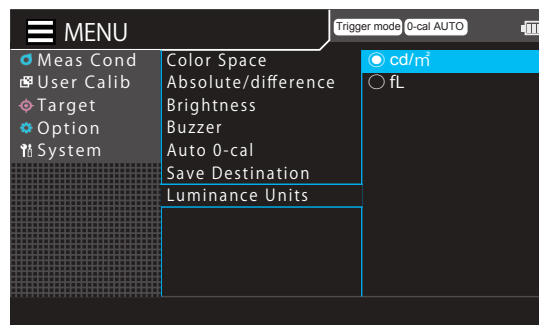
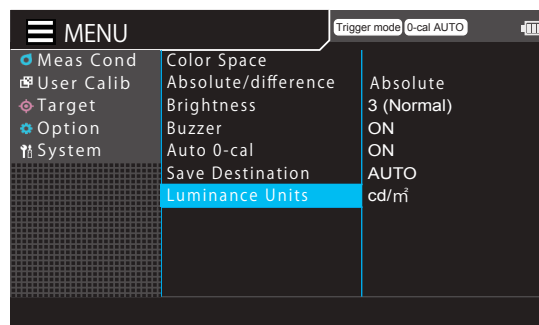
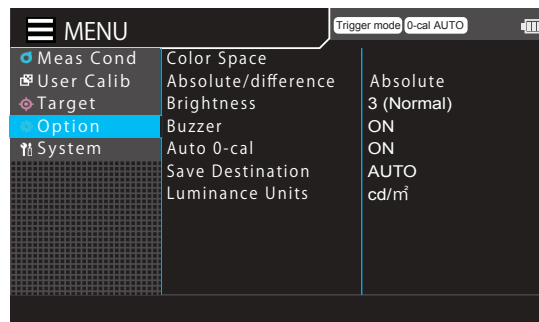

# Setting the Power Save mode

To save battery, this instrument can be set to turn off automatically if no operation or communication is performed for a specified time. The Power Save mode functions even when measuring.

\* Factory setting: ON

## Operating Procedure

- 1 While the measurement screen is displayed, press the [MENU] key.**  
The setting screen is displayed on the LCD screen.
- 2 Press the [UP] or [DOWN] key to select [System], and then press the [RIGHT] or [ENTER] key.**
- 3 Press the [UP] or [DOWN] key to select [Power Save mode], and then press the [ENTER] key.**
- 4 The screen for turning the Power Save mode ON/OFF is displayed. Press the [UP] or [DOWN] key to select whether to turn ON or OFF the Auto Power Off, and then press the [ENTER] key.**
- 5 When [ON] is selected, the screen for selecting the time between the last operation or communication and power-off is displayed. Press the [UP] or [DOWN] key to select the time.**
- 6 Press the [ESC] key.**  
The measurement screen is displayed on the LCD screen.  
The Power Save mode setting will be kept even if the POWER switch is set to OFF (○).

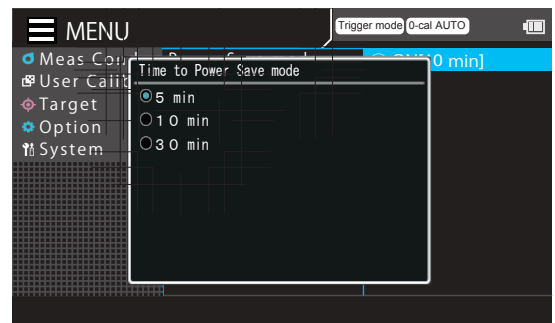
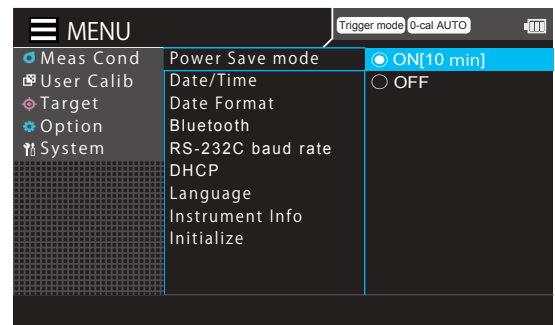
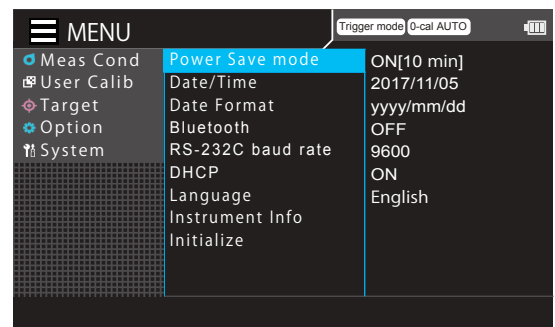
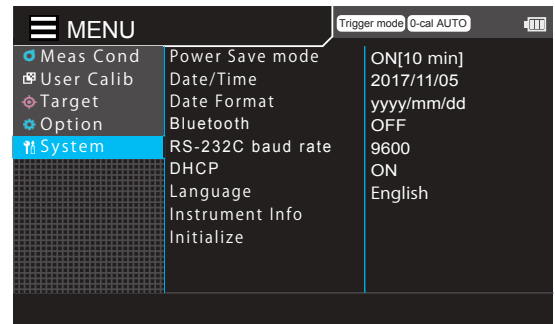

# Setting the Internal Clock

The instrument contains an internal clock to record the measurement date and time. Set the date and time of this internal clock.

## Operating Procedure

- 1 While the measurement screen is displayed, press the [MENU] key.**  
The setting screen is displayed on the LCD screen.
- 2 Press the [UP] or [DOWN] key to select [System], and then press the [RIGHT] or [ENTER] key.**
- 3 Press the [UP] or [DOWN] key to select [Date/Time], and then press the [ENTER] key.**
- 4 Press the [UP] or [DOWN] key to select date and time, and then press the [ENTER] key.**
- 5 Press the [UP] or [DOWN] key to set the desired value.**  
Holding down the key changes the value continuously.
- 6 Press the [RIGHT] key to move the cursor to the next item.**  
Pressing the [LEFT] key moves the cursor to the previous item.
- 7 Repeat steps 5 and 6 for the necessary items.**  
The available range of years is from 2015 to 2099. To cancel configuration of the setting in the middle of the procedure, press the [ESC] key.
- 8 Press the [ESC] key twice.**  
The measurement screen is displayed on the LCD screen.

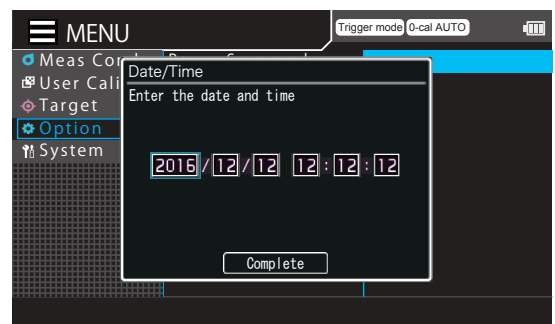
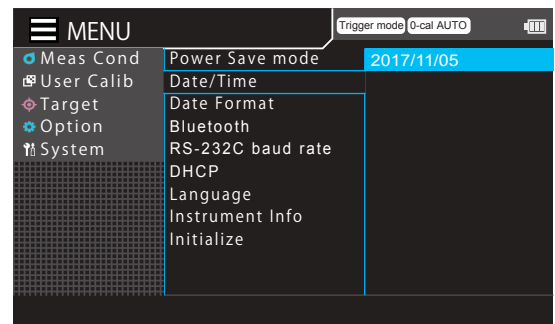
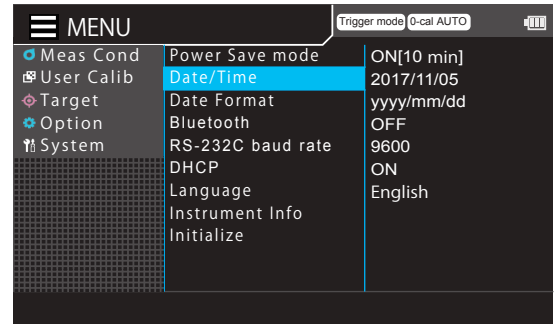
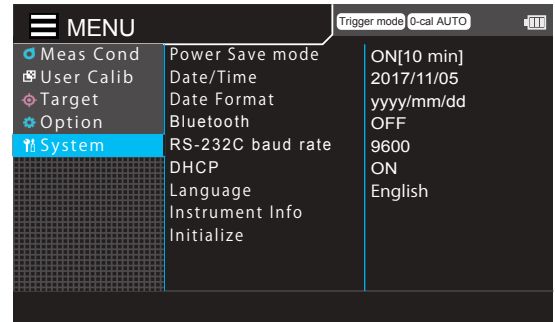



# Setting the Date Format

The instrument contains an internal clock to record the measurement date and time. Set the display format of this date and time.

## Operating Procedure

- 1 While the measurement screen is displayed, press the [MENU] key.**  
The setting screen is displayed on the LCD screen.
- 2 Press the [UP] or [DOWN] key to select [System], and then press the [RIGHT] or [ENTER] key.**
- 3 Press the [UP] or [DOWN] key to select [Date Format], and then press the [ENTER] key.**
- 4 Press the [UP] or [DOWN] key to select the desired date format, and then press the [ENTER] key.**
- 5 Press the [ESC] key twice.**  
The measurement screen is displayed on the LCD screen.  
The date format setting will be kept even if the POWER switch is set to OFF (○).

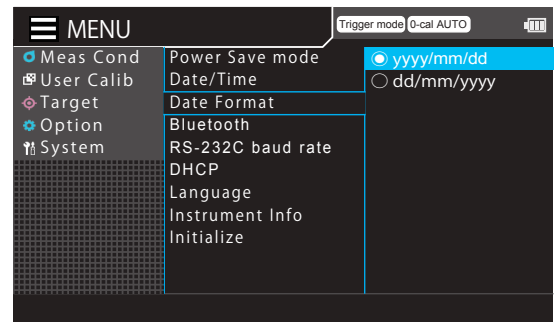
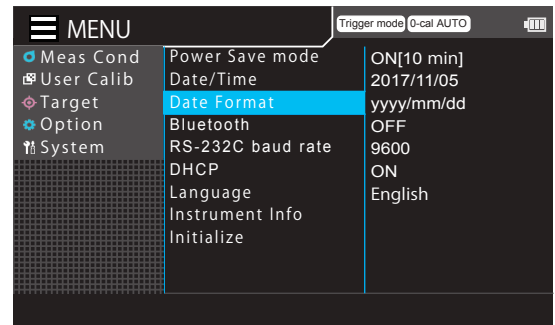
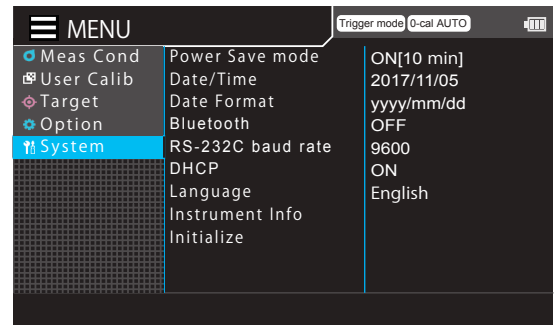

# Selecting the Display Language

This instrument allows users to select the language displayed on the external LCD screen. Select the language from English, Japanese, Simplified Chinese, Traditional Chinese, and Korean.

## Operating Procedure

- 1 While the measurement screen is displayed, press the [MENU] key.**  
The setting screen is displayed on the LCD screen.
- 2 Press the [UP] or [DOWN] key to select [System], and then press the [RIGHT] or [ENTER] key.**
- 3 Press the [UP] or [DOWN] key to select [Language], and then press the [ENTER] key.**
- 4 The screen for selecting a language is displayed. Press the [UP] or [DOWN] key to select the language to display and then press the [ENTER] key.**
- 5 Press the [ESC] key.**  
The measurement screen is displayed on the LCD screen.  
The language setting will be kept even if the POWER switch is set to OFF (○).

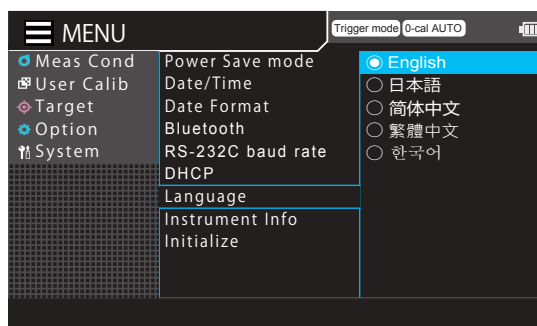
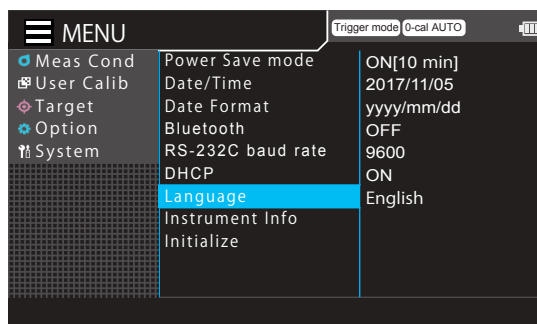
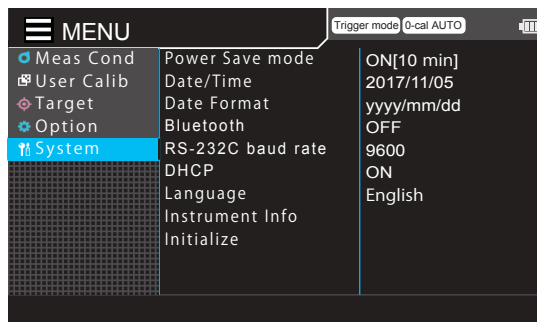

# Checking the Instrument Information

Information about the data processor, such as the serial number and firmware version, can be viewed.

## Operating Procedure

- 1 While the measurement screen is displayed, press the [MENU] key.**  
The setting screen is displayed on the LCD screen.
- 2 Press the [UP] or [DOWN] key to select [System], and then press the [RIGHT] or [ENTER] key.**
- 3 Press the [UP] or [DOWN] key to select [Instrument Info], and then press the [ENTER] key.**  
Version and other information about the instrument are displayed on the LCD screen.
- 4 Press the [ESC] key twice.**  
The measurement screen is displayed on the LCD screen.

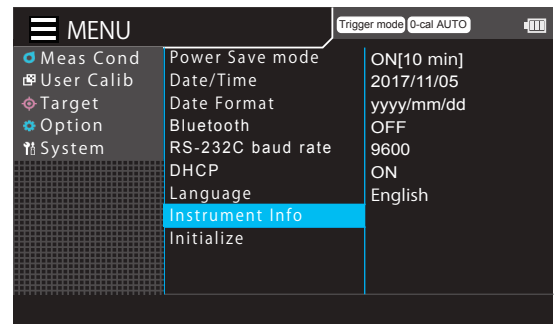
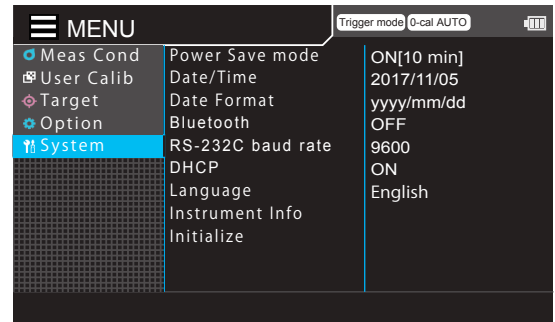

# Initializing the Settings

This function resets the settings back to the factory settings. The initialization does not delete the measured values, target values, and user calibration information stored in the instrument.

## Operating Procedure

### 1 While the measurement screen is displayed, press the [MENU] key.

The setting screen is displayed on the LCD screen.

### 2 Press the [UP] or [DOWN] key to select [System], and then press the [RIGHT] or [ENTER] key.

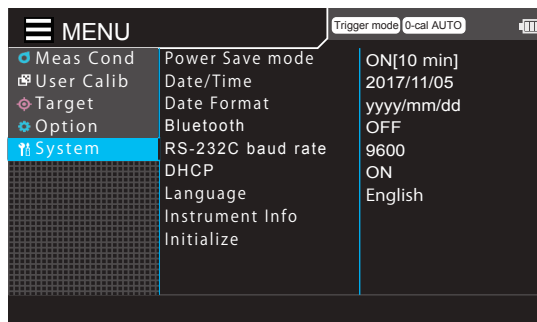

### 3 Press the [UP] or [DOWN] key to select [Initialize], and then press the [ENTER] key.

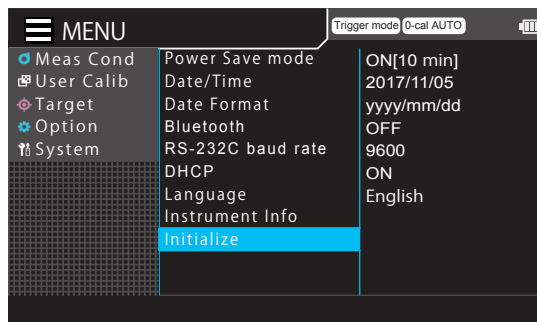

### 4 The screen for selecting whether or not to initialize the instrument is displayed. Press the [RIGHT] or [LEFT] key to make a selection, and then press the [ENTER] key.

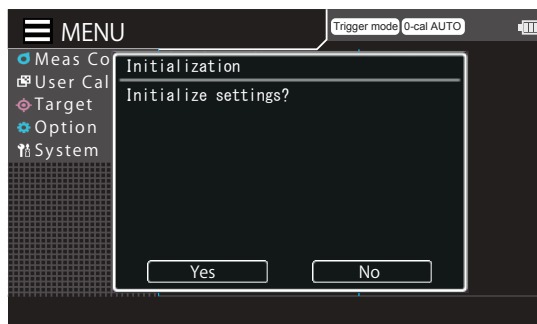

### 5 Press the [ESC] key twice.

The measurement screen is displayed on the LCD screen.

# Communication

This section explains communication with a PC via RS-232C, USB, Ethernet, or Bluetooth.

<p><b>Connection to a PC via RS-232C</b> Explains how to connect an RS-232C cable and select the RS-232C baud rate to enable two-way communication with a PC or other device via RS-232C.</p>	P. 108
<p><b>Connection to a PC via USB</b> Explains how to connect a cable to enable communication with a PC via USB.</p>	P. 110
<p><b>Connection to a PC via Ethernet</b> Explains how to connect a cable and set the DHCP to enable communication with a PC via Ethernet.</p>	P. 111
<p><b>Connection to a PC via Bluetooth</b> Explains how to connect and set the Bluetooth module to enable communication with a PC or other device via Bluetooth.</p>	P. 114

## Communicating with a PC

- Bidirectional communication is possible between the data processor and a PC using an RS-232C, USB, Ethernet, or Bluetooth connection.  
When multiple means of communication are set, the means of communication used for sending the first command from the PC will be enabled, and commands from all other means will be ignored.
- If the USB cable will be connected and disconnected frequently, please try to use RS-232C for connection. If any problem occurs, contact a Konica Minolta-authorized service facility.

# RS-232C Connection

## 1. Connection to a PC or PLC via RS-232C

Before setting the POWER switch to ON (|), connect an RS-232C cable (9-pin D-sub) to the RS-232C connector on the instrument.

The RS-232C connector on the instrument is a 9-pin D-sub female connector.

### Operating Procedure

- 1 Set the POWER switch to OFF (○).
- 2 Connect the data processor to a PC or PLC with an RS-232C cable.
- 3 Make sure that the cable is firmly connected to the RS-232C connector with the connector's right and left screws.

#### Notes

When disconnecting the RS-232C cable, set the POWER switch to OFF (○) first, and pull the cable by holding the plug. Never pull the cable by its cord.

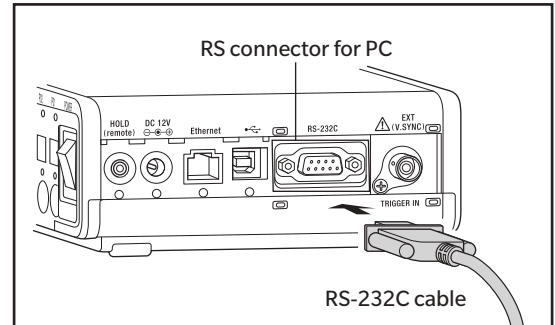

### RS-232C connector pin numbers

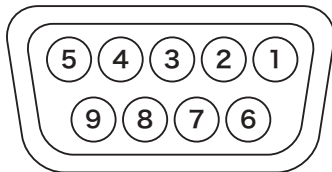

Pin No.	Signal	Input/output	Details
1			N.C.
2	RXD	Input	Received data
3	TXD	Output	Transmitted data
4			N.C.
5	GND		
6			N.C.
7	RTS	Output	Request To Send
8	CTS	Input	Clear To Send
9			N.C.

## 2. Setting the RS-232C Baud Rate

This instrument allows users to set a baud rate for RS-232C connection.

\* Factory setting: 38400 bps

### Operating Procedure

- 1 While the measurement screen is displayed, press the [MENU] key.**  
The setting screen is displayed on the LCD screen.
- 2 Press the [UP] or [DOWN] key to select [System], and then press the [RIGHT] or [ENTER] key.**
- 3 Press the [UP] or [DOWN] key to select [RS-232C baud rate], and then press the [ENTER] key.**
- 4 The screen for selecting a baud rate is displayed. Press the [UP] or [DOWN] key to select a baud rate.**  
Options: 600, 1200, 2400, 4800, 9600, 19200, 38400, 57600, 115200, 230400
- 5 Press the [ESC] key.**  
The measurement screen is displayed on the LCD screen.  
The baud rate setting will be kept even if the POWER switch is set to OFF (○).

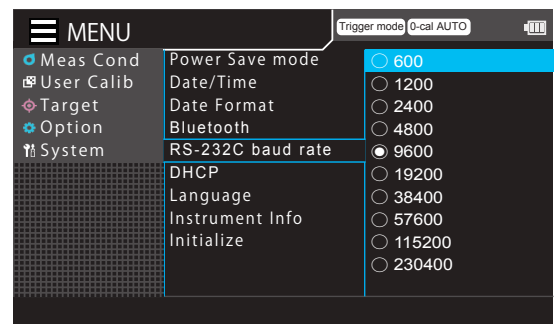
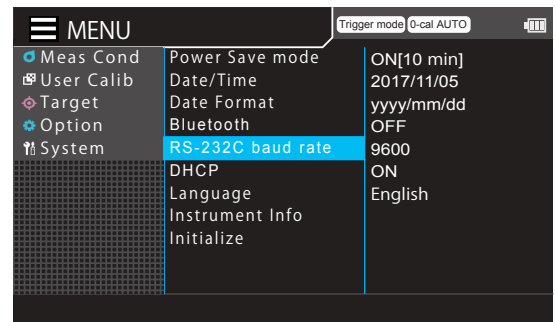
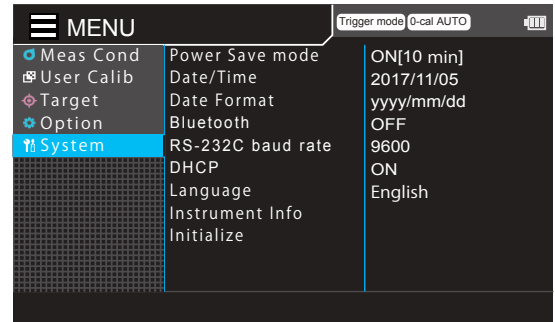

# USB Connection

## 1. Connection to a PC via USB

A USB cable can be connected/disconnected even if the power to the instrument is ON. In the following procedure, however, the power is turned OFF before a cable is connected.

Connect the instrument to a PC with the optional USB cable IF-A34 (2 m).

### Notes

- To connect the data processor to a PC, the dedicated USB driver must be installed. Use the USB driver included with the PC software that becomes available when the instrument is connected to a PC.
- Connect the USB connector plug firmly in the correct direction.
- When connecting/disconnecting the USB cable, be sure to hold the connector plug. Do not hold the cable and pull or bend it with unreasonable force. Doing so may break the cable.
- Make sure that the cable has sufficient length. Putting tension on the cable may cause connection failure or wire breakage.
- Pay attention to the shape of the port (connecting terminal) for the USB cable connector, and push the connector completely into the port.

### Memo

- The USB communication port of the instrument conforms to USB 2.0.

### Operating Procedure

- 1 Set the POWER switch to OFF (○).**
- 2 Connect the plugs of the USB cable to the USB connectors of the data processor and the PC.**
- 3 Check that the plugs are inserted all the way and connected firmly.**
- 4 Turn the instrument power ON.**

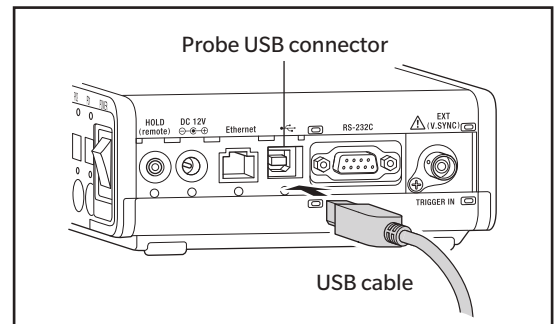

- If the PC has several USB ports, any port can be used. Note, however, that the instrument may not operate properly when it is used simultaneously with another USB device.

### Notes on Communication via USB

- To control multiple data processors from one computer via both RS-232C and USB, connect only one data processor via USB. It is not possible to control data processors via RS-232C when connecting two or more data processors via USB.



# Ethernet Connection

## 1. Connection to a PC via Ethernet

An Ethernet cable can be connected/disconnected even if the power to the instrument is ON. In the following procedure, however, the power is turned OFF before a cable is connected.

Use an Ethernet cable to connect the instrument to a PC.

### Notes

- Connect the connector plug firmly in the correct direction.
- When connecting/disconnecting the cable, be sure to hold the connector plug. Do not hold the cable and pull or bend it with unreasonable force. Doing so may break the cable.
- Make sure that the cable has sufficient length. Putting tension on the cable may cause connection failure or wire breakage.
- Pay attention to the shape of the port (connecting terminal) for the cable connector, and push the connector completely into the port.

### Operating Procedure

- 1 Set the POWER switch to OFF (○).**
- 2 Connect an Ethernet cable to the Ethernet connector of the instrument.**
- 3 Check that the plugs are inserted all the way and connected firmly.**
- 4 Turn the instrument power ON.**

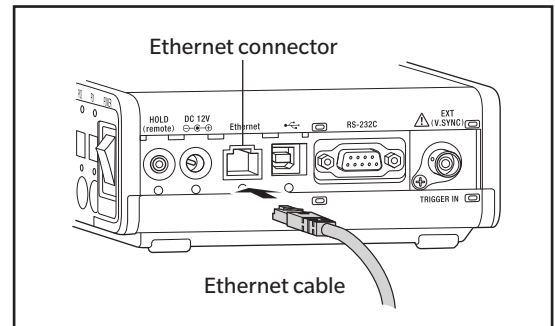

- As an Ethernet cable, use a 100Base-TX or a 10Base-T cable.
- If the PC has several Ethernet ports, any port can be used. Note, however, that the instrument may not operate properly when it is used simultaneously with another device.

## 2. Setting the DHCP

This instrument allows users to turn communication ON/OFF to enable Ethernet connection to a PC and to set the properties (IP address, subnet mask, and default gateway).

\* Factory setting: OFF

### Operating Procedure

- 1 While the measurement screen is displayed, press the [MENU] key.**  
The setting screen is displayed on the LCD screen.
- 2 Press the [UP] or [DOWN] key to select [System], and then press the [RIGHT] or [ENTER] key.**
- 3 Press the [UP] or [DOWN] key to select [DHCP], and then press the [ENTER] key.**
- 4 To enable communication, press the [UP] or [DOWN] key and select [OFF]. Press the [ENTER] key.**
- 5 Press the [UP] or [DOWN] key to set the desired value.**  
Holding down the key changes the value continuously.
- 6 Press the [RIGHT] key to move the cursor to the next item.**  
Pressing the [LEFT] key moves the cursor to the previous item.

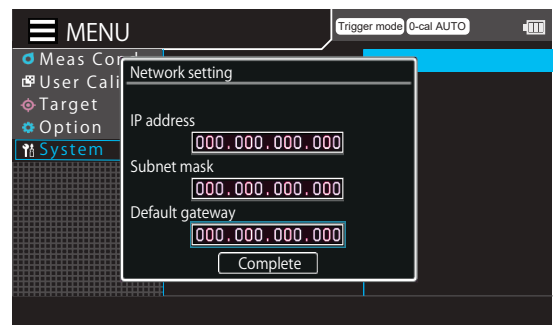
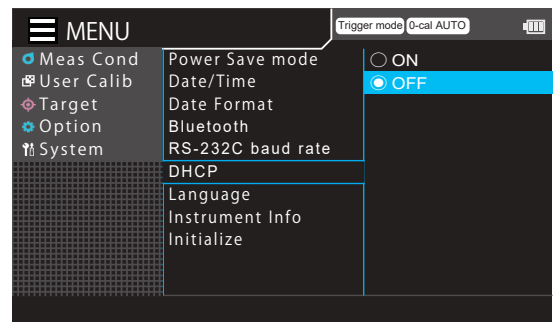
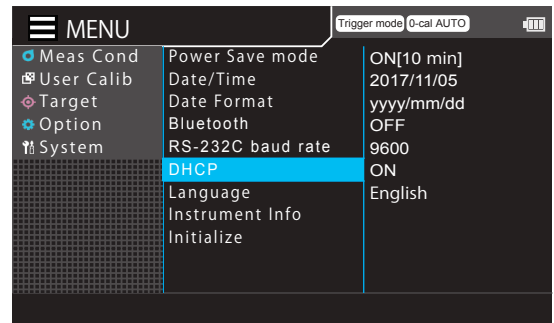
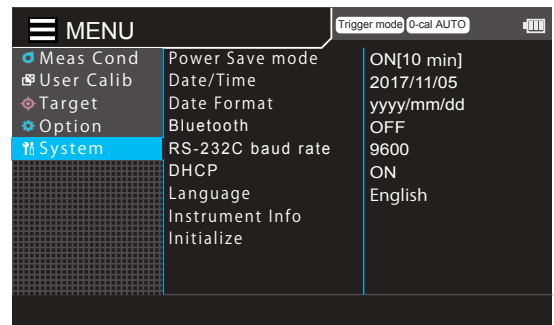

---

## **7 Repeat steps 5 and 6 for the necessary items.**

To cancel configuration of the setting in the middle of the procedure, press the [ESC] key.

## **8 Move to [Complete] and press the [ENTER] key.**

## **9 Press the [ESC] key twice.**

The measurement screen is displayed on the LCD screen.

The DHCP setting will be kept even if the POWER switch is set to OFF (○).

# Bluetooth Connection

## 1. Connecting via a Bluetooth Module

Connect the instrument to a PC with Bluetooth communication functionality using the optional Bluetooth module.

### Memo

To connect the instrument to a PC via the Bluetooth function, appropriate preparations for Bluetooth communication must be performed in advance for both the instrument and the printer.

### ○ Preparation on the Instrument

Connect the optional Bluetooth module CM-A219.

Turn ON the instrument's Bluetooth function and configure the PIN code on the instrument as required.

### Operating Procedure

- 1 Remove the screw from the Bluetooth module slot on the instrument, slide the cover to open it, and insert the Bluetooth module.**

#### Notes

When inserting the Bluetooth module, please note that the module will be slightly loose. Pushing forcibly on the module may damage the connector if the module and the connector on the instrument are not aligned correctly.

- 2 Slide the cover to close it, and tighten the screw.**

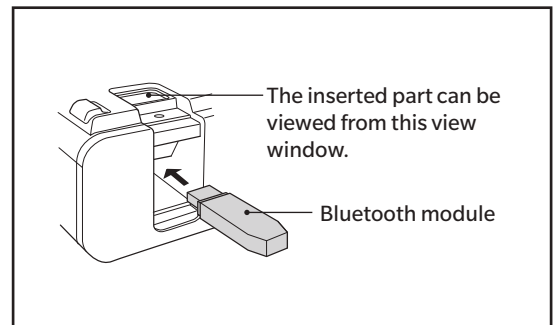
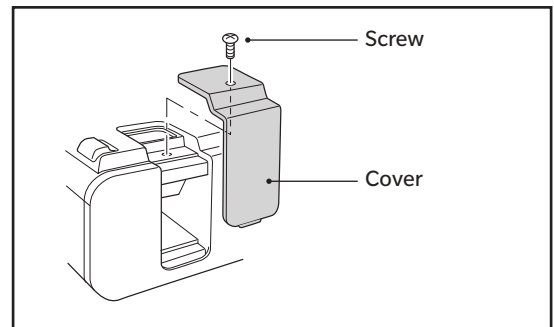

## 2. Turning Bluetooth ON

**Memo** By default, the Bluetooth function is set to “OFF”.

### Operating Procedure

- 1 While the measurement screen is displayed, press the [MENU] key.**  
The setting screen is displayed on the LCD screen.
- 2 Press the [UP] or [DOWN] key to select [System], and then press the [RIGHT] or [ENTER] key.**
- 3 Use the [UP] or [DOWN] key to move the cursor to “Bluetooth”, and then press the [ENTER] key.**  
The <Bluetooth> screen is displayed.
- 4 Use the [UP] or [DOWN] key to move the cursor to “ON”, and then press the [ENTER] key.**  
The instrument’s Bluetooth function is turned ON.
- 5 Press the [ESC] key twice.**  
The measurement screen is displayed on the LCD screen.

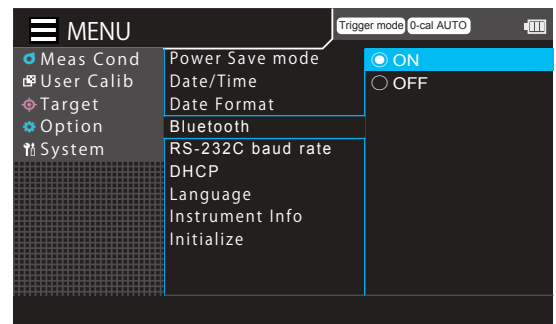
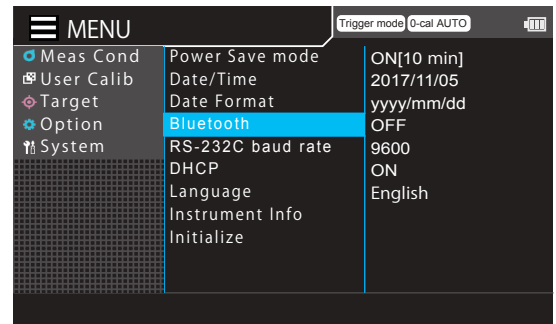
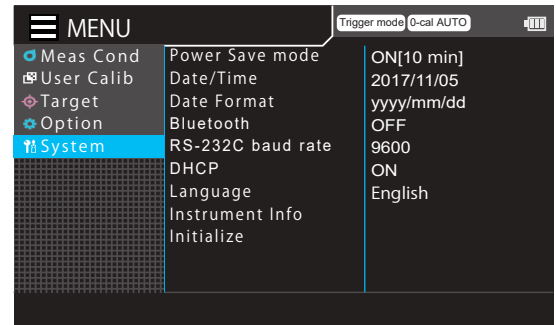

### 3. PC Connection

With the PC as a host, a connection to the instrument can be established using Bluetooth communication.

#### Operating Procedure

- 1** Verify that the instrument power has been turned ON.
- 2** Verify that the Bluetooth function on the instrument has been turned ON. Also verify that the instrument is not connected to the PC via another connection method.
- 3** Start the Bluetooth utility on the PC.
- 4** Search for nearby Bluetooth devices, and select "CM-A219" from the list of displayed devices.
- 5** Enter the PIN code written in the instruction manual included with the CM-A219 on the PC.
- 6** Open the Bluetooth serial port to connections.

Once the connection has been established and communication has started, the Bluetooth icon will be displayed in the status display area on the instrument.

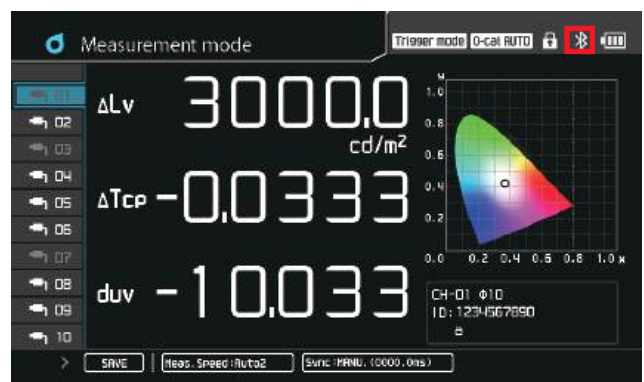

# Explanation

This section explains the following items.

<b>Dimensions</b>	P. 118
<b>Error Messages</b> Please read when an error message appears on the LCD display.	P. 119
<b>Main Specifications</b>	P. 120

# Dimensions

(Unit: mm)

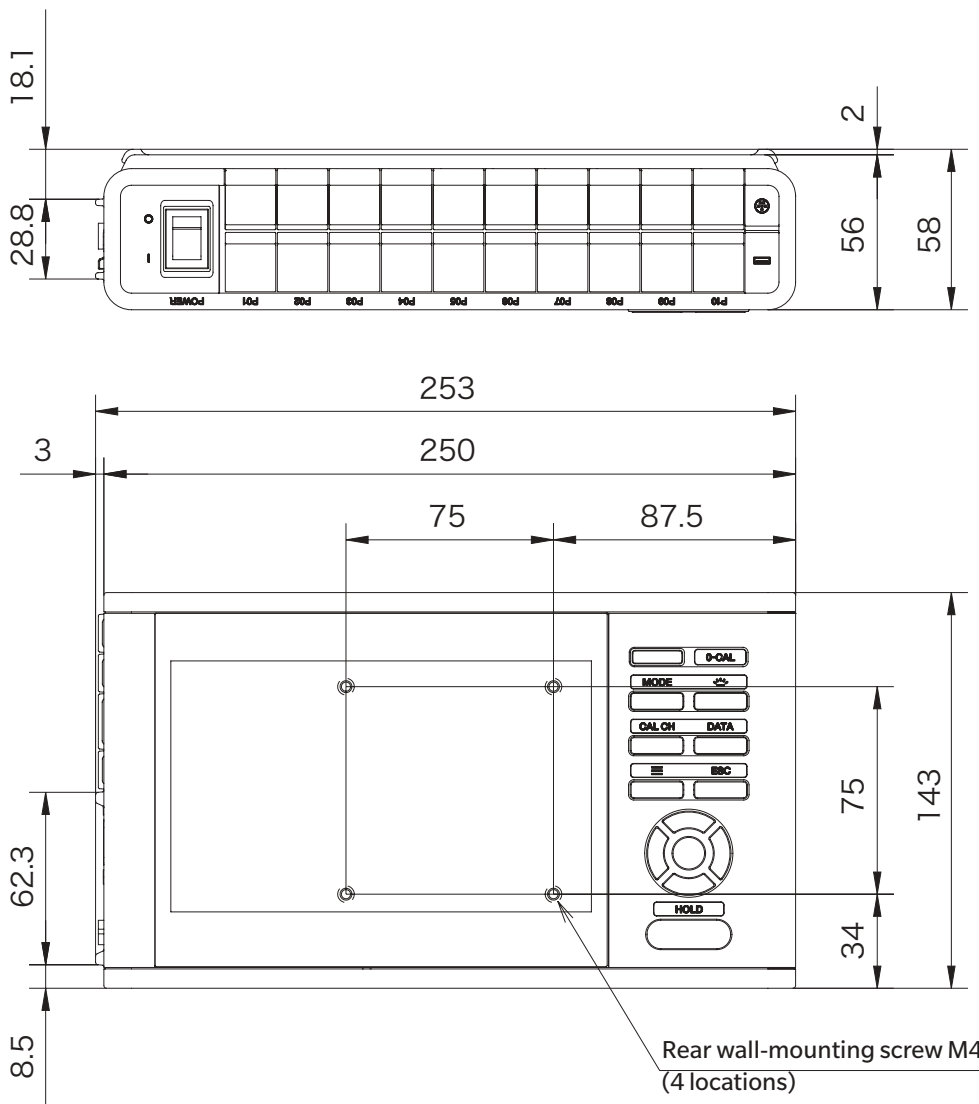



# Errors and Countermeasures

The following table shows countermeasures to be taken when an error message is displayed or the instrument does not operate as expected. If the error is not addressed even after taking necessary countermeasures, contact a KONICA MINOLTA-authorized service facility.

Error	Error code	Countermeasure
Probe connection error Failed to connect to probe Retry connecting to probe		Retry connecting to the probe.
Memory Error Failed to save meas data Retry the operation		Retry the operation. If the problem persists, contact a KONICA MINOLTA-authorized service facility.
Memory Error Failed to save interval data Check memory size		Check the memory size.
Memory Error Failed to delete data Retry the operation		Retry the operation. If the problem persists, contact a KONICA MINOLTA-authorized service facility.
Memory Error Retry power on		Restart the device. If the problem persists, contact a KONICA MINOLTA-authorized service facility.
0-cal Error Failed to shade Retry 0-cal	ER21	Retry zero calibration so that the brightness of the measurement target (the brightness around the measuring instrument) does not exceed the measurable range for the instrument. In such cases, turn the power OFF and back ON if possible, and then retry zero calibration. If the problem persists, contact a KONICA MINOLTA-authorized service facility.
Memory Error Failed to write or read memory Reconnect the probe	ER31 ER32	Reconnect the probe. If the problem persists, contact a KONICA MINOLTA-authorized service facility.
System Error Probe program error	ER99	Download the updated firmware from the Konica Minolta website to update the firmware. If the problem persists, contact a KONICA MINOLTA-authorized service facility.
Probe connection Connected device is not CA series Remove other devices		Only connect dedicated probes.
Probe connection Probe connection number is over limit Maximum of 10 probes		Reduce the number of connected probes to 10 or less.
Probe connection error Retry connecting to probe		Reconnect the probe. If the problem persists, contact a KONICA MINOLTA-authorized service facility.
Key operation is not possible		Verify that the keys are not locked. Press and hold the [ESC] key for 2 seconds or more to unlock the keys.

# Main Specifications

Display Range	Luminance	0.0001 to 30000 cd/m <sup>2</sup>
	Chromaticity	Displayed in 4 digits
	Flicker	(Contrast) (JEITA)
		0.00 to 999.99%
		To 2 decimal places
Display		7-inch color LCD WVGA
Display Items		L <sub>v</sub> x y (ΔL <sub>v</sub> Δx Δy) L <sub>v</sub> u' v' (ΔL <sub>v</sub> Δu' Δv') L <sub>v</sub> Tcp duv (ΔL <sub>v</sub> ΔTcp duv) X Y Z (ΔX ΔY ΔZ) L <sub>v</sub> λd Pe (ΔL <sub>v</sub> Δλd ΔPe) Flicker (Contrast) Flicker (JEITA)
Measurement data storage channels		100 CH
Data logging function		Available
Display Languages		English, Chinese (Traditional, Simplified), Korean, Japanese
Interfaces	For computer, etc.	USB 2.0 RS-232C Ethernet [Optional accessory] Bluetooth (module required)
	For probes	Mini-DIN 8-pin cable (for RS communication) USB (for USB communication)
	Sync signal input	BNC connector (with trigger input)
Multi probe connection		10 max.
Operating Temp./Humid. Range		10 to 35°C, relative humidity 85% or less with no condensation
Storage Temp./Humid. Range		0 to 45°C, relative humidity 85% or less (at 35°C) with no condensation
Power		AC adapter [Optional accessory] Lithium-ion battery (removable)
Battery life		3 hours (when using 1 probe)
Size		253 (W) × 58 (H) × 143 (D) mm
Weight		1.6 kg
Accessories	Standard	AC cable Probe-DP RS cable (2 m) IF-A30 AC adapter AC-A312F
	Optional	USB cable for DP-PC (2 m) IF-A34 Probe-DP RS cable (5 m) IF-A31, (10 m) IF-A32 Lithium-ion battery CM-A223 Bluetooth module CM-A219 Carrying case CA-A01

---

**< CAUTION >**

- KONICA MINOLTA WILL NOT BE LIABLE FOR ANY DAMAGES RESULTING FROM THE MISUSE, MISHANDLING, UNAUTHORIZED MODIFICATION, ETC. OF THIS PRODUCT, OR FOR ANY INDIRECT OR INCIDENTAL DAMAGES (INCLUDING BUT NOT LIMITED TO LOSS OF BUSINESS PROFITS, INTERRUPTION OF BUSINESS, ETC.) DUE TO THE USE OF OR INABILITY TO USE THIS PRODUCT.



KONICA MINOLTA

		CA-VP427A	CA-P427	CA-P427H	CA-VP410A	CA-VP410T	CA-P410	CA-P410H	CA-VP404	CA-VP402		
		Advanced High Sensitivity Probe	Normal Probe	High Luminance Probe	Advanced High Sensitivity Probe	LWD Probe	Normal Probe	High Luminance Probe	Small Spot Probe	Small Spot Probe		
Measurement area		Ø 27 mm	Ø 27 mm	Ø 27 mm	Ø 10 mm	Approx. Ø 10 mm	Ø 10 mm	Ø 10 mm	Ø 4 mm	Ø 2.1 mm		
Acceptance angle		± 2.5°	± 2.5°	± 2.5°	± 8.5°	± 4°	± 5°	± 5°	± 8.5°	± 10°		
Accuracy guaranteed measurement distance		30 ± 10 mm	30 ± 10 mm	30 ± 10 mm	30 ± 5 mm	200 ± 2 mm	30 ± 5 mm	30 ± 5 mm	30 ± 2 mm	28 ± 2 mm		
Accuracy guaranteed range <sup>1)</sup>		0.0003 to 5,000 cd/m <sup>2</sup>	0.001 to 5,000 cd/m <sup>2</sup>	0.01 to 30,000 cd/m <sup>2</sup>	0.0003 to 3,000 cd/m <sup>2</sup>	0.004 to 12,000 cd/m <sup>2</sup>	0.002 to 10,000 cd/m <sup>2</sup>	0.1 to 30,000 cd/m <sup>2</sup>	0.004 to 12,000 cd/m <sup>2</sup>	0.002 to 25,000 cd/m <sup>2</sup>		
Luminance	Accuracy (for white) <sup>1), 3)</sup>	> 0.0003 cd/m <sup>2</sup>	± 9 %	---	± 9 %	---	± 9 %	---	± 9 % (0.004 to cd/m <sup>2</sup> )	± 9 % (0.002 to cd/m <sup>2</sup> )		
		> 0.001 cd/m <sup>2</sup>	± 4 %	---	± 4 %	---	± 9 % (0.004 to cd/m <sup>2</sup> )	± 9 % (0.002 to cd/m <sup>2</sup> )	---	± 9 % (0.004 to cd/m <sup>2</sup> )		
		> 0.01 cd/m <sup>2</sup>	± 2 %	± 9 %	± 2 %	± 9 %	± 2 %	± 2 %	± 9 %	± 2 %	± 9 %	
		> 0.1 cd/m <sup>2</sup>	± 1.5 %	± 1.5 %	± 2 %	± 2 %	± 3 %	± 2 %	± 2.5 %	± 3 %	± 3 %	
		> 1 cd/m <sup>2</sup>	± 1.5 %	± 1.5 %	± 1.5 %	± 2 %	± 3 %	± 2 %	± 2 %	± 3 %	± 3 %	
		> 10 cd/m <sup>2</sup>	± 1.5 %	± 1.5 %	± 1.5 %	± 1.5 %	± 2.5 %	± 1.5 %	± 2 %	± 2.5 %	± 2.5 %	
	Repeatability (2σ) <sup>1)</sup>	AUTO	> 0.0003 cd/m <sup>2</sup>	10 %	---	7 %	---	---	---	---	---	
			> 0.001 cd/m <sup>2</sup>	4 %	10 %	---	3 %	10 % (0.004 to cd/m <sup>2</sup> )	10 % (0.002 to cd/m <sup>2</sup> )	---	10 % (0.002 to cd/m <sup>2</sup> )	
			> 0.01 cd/m <sup>2</sup>	1 %	1 %	10 %	1 %	5 %	2 %	---	5 %	10 %
			> 0.1 cd/m <sup>2</sup>	0.25 %	0.40 %	1 %	0.25 %	0.50 %	0.60 %	2 %	0.50 %	1 %
Accuracy guaranteed luminance range <sup>1)</sup>		0.0003 to 5,000 cd/m <sup>2</sup>	0.01 to 5,000 cd/m <sup>2</sup>	0.1 to 30,000 cd/m <sup>2</sup>	0.003 to 3,000 cd/m <sup>2</sup>	0.04 to 12,000 cd/m <sup>2</sup>	0.01 to 10,000 cd/m <sup>2</sup>	0.1 to 30,000 cd/m <sup>2</sup>	0.04 to 12,000 cd/m <sup>2</sup>	0.02 to 25,000 cd/m <sup>2</sup>		
Chromaticity	Accuracy (for white) <sup>1), 3)</sup>	> 0.003 cd/m <sup>2</sup>	± 0.003	---	± 0.003	---	± 0.006	---	± 0.004 (0.04 to cd/m <sup>2</sup> )	± 0.004 (0.02 to cd/m <sup>2</sup> )		
		> 0.01 cd/m <sup>2</sup>	± 0.002	± 0.003	---	± 0.002	± 0.004 (0.04 to cd/m <sup>2</sup> )	± 0.002	± 0.006	± 0.004 (0.02 to cd/m <sup>2</sup> )		
		> 0.1 cd/m <sup>2</sup>	± 0.002	± 0.002	± 0.003	± 0.002	± 0.003	± 0.002	± 0.002	± 0.003		
		> 1 cd/m <sup>2</sup>	± 0.002	± 0.002	± 0.002	± 0.002	± 0.003	± 0.002	± 0.002	± 0.003		
		> 10 cd/m <sup>2</sup>	± 0.002	± 0.002	± 0.002	± 0.002	± 0.003	± 0.002	± 0.002	± 0.003		
		> 100 cd/m <sup>2</sup>	± 0.002	± 0.002	± 0.002	± 0.002	± 0.002	± 0.002	± 0.002	± 0.002		
	At 100 cd/m <sup>2</sup> (for monochrome) <sup>1), 2)</sup>	AUTO	> 100 cd/m <sup>2</sup>	± 0.003	± 0.003	± 0.003	± 0.003	± 0.003	± 0.003	± 0.003	± 0.003	
			> 0.003 cd/m <sup>2</sup>	0.0030	---	---	0.0020	---	---	---	---	
			> 0.01 cd/m <sup>2</sup>	0.0030	0.0035	---	0.0020	0.0030 (0.04 to cd/m <sup>2</sup> )	0.0070	---	0.0030 (0.04 to cd/m <sup>2</sup> )	
			> 0.1 cd/m <sup>2</sup>	0.0008	0.0015	0.0035	0.0008	0.0015	0.0020	0.0070	0.0015	0.003
Measurement luminance range <sup>1)</sup>		5 to 3,000 cd/m <sup>2</sup>	5 to 5,000 cd/m <sup>2</sup>	30 to 30,000 cd/m <sup>2</sup>	15 to 3,000 cd/m <sup>2</sup>	20 to 12,000 cd/m <sup>2</sup>	15 to 10,000 cd/m <sup>2</sup>	90 to 30,000 cd/m <sup>2</sup>	20 to 12,000 cd/m <sup>2</sup>	35 to 25,000 cd/m <sup>2</sup>		
Flicker (CA-310 Mode) <sup>6)</sup>	Flicker (Contrast)	Measurement target (Flicker frequency)	---	5 to 1,500 cd/m <sup>2</sup>	30 to 9,000 cd/m <sup>2</sup>	---	---	15 to 3,000 cd/m <sup>2</sup>	90 to 18,000 cd/m <sup>2</sup>	---		
		Accuracy	30 Hz, AC/DC 10% sine wave	± 0.4 %	± 0.4 %	± 0.4 %	---	± 0.4 %	± 0.4 %	± 0.4 %	---	
		Repeatability (2σ)	20-65 Hz, AC/DC 10% sine wave	0.3 %	0.3 %	0.3 %	---	0.3 %	0.3 %	0.3 %	---	
		Measurement luminance range <sup>1)</sup>	---	5 to 1,500 cd/m <sup>2</sup>	30 to 9,000 cd/m <sup>2</sup>	---	---	15 to 3,000 cd/m <sup>2</sup>	90 to 18,000 cd/m <sup>2</sup>	---	---	
	Flicker (JEITA)	Measurement target (Flicker frequency)	---	0.42 to 65 Hz	0.42 to 65 Hz	---	---	0.42 to 65 Hz	0.42 to 65 Hz	---	---	
		Accuracy	30 Hz, AC/DC 4% sine wave	± 0.35 dB	± 0.35 dB	± 0.35 dB	---	± 0.35 dB	± 0.35 dB	---	---	
		Repeatability (2σ)	30 Hz, AC/DC 4% sine wave	0.1 dB	0.1 dB	0.1 dB	---	0.1 dB	0.1 dB	---	---	
		Measurement luminance range <sup>1)</sup>	---	5 to 1,500 cd/m <sup>2</sup>	30 to 9,000 cd/m <sup>2</sup>	---	---	15 to 3,000 cd/m <sup>2</sup>	90 to 18,000 cd/m <sup>2</sup>	---	---	
	XYZ (Wide Frequency Mode) <sup>6)</sup>	Flicker (Contrast)	Measurement target (Flicker frequency)	0.25 to 200 Hz	0.25 to 200 Hz	0.25 to 200 Hz	0.25 to 200 Hz	0.25 to 200 Hz	0.25 to 200 Hz	0.25 to 200 Hz	0.25 to 200 Hz	
			Accuracy	30 Hz, AC/DC 10% sine wave	± 1.1 %	± 1.2 %	± 1.2 %	± 1.1 %	± 1.1 %	± 1.1 %	± 1.1 %	± 1.1 %
Repeatability (2σ)			20-65 Hz, AC/DC 10% sine wave	1.6 %	1.7 %	1.7 %	0.3 %	0.016	1.0 %	1.0 %	1.6 %	
Measurement luminance range <sup>1)</sup>			5 to 3,000 cd/m <sup>2</sup>	5 to 5,000 cd/m <sup>2</sup>	30 to 30,000 cd/m <sup>2</sup>	15 to 3,000 cd/m <sup>2</sup>	20 to 12,000 cd/m <sup>2</sup>	15 to 10,000 cd/m <sup>2</sup>	90 to 30,000 cd/m <sup>2</sup>	20 to 12,000 cd/m <sup>2</sup>	35 to 25,000 cd/m <sup>2</sup>	
Flicker (JEITA)		Measurement target (Flicker frequency)	0.42 to 200 Hz	0.42 to 200 Hz	0.42 to 200 Hz	0.42 to 200 Hz	0.42 to 200 Hz	0.42 to 200 Hz	0.42 to 200 Hz	0.42 to 200 Hz	0.42 to 200 Hz	
		Accuracy	30 Hz, AC/DC 4% sine wave	± 0.35 dB	± 0.35 dB	± 0.35 dB	± 0.35 dB	± 0.35 dB	± 0.35 dB	± 0.35 dB	± 0.35 dB	
		Repeatability (2σ)	30 Hz, AC/DC 4% sine wave	0.4 dB	0.4 dB	0.4 dB	0.1 dB	0.4 dB	0.3 dB	0.3 dB	0.4 dB	
		Measurement luminance range <sup>1)</sup>	1 to 3,000 cd/m <sup>2</sup>	1 to 5,000 cd/m <sup>2</sup>	6 to 30,000 cd/m <sup>2</sup>	1 to 2,500 cd/m <sup>2</sup>	4 to 12,000 cd/m <sup>2</sup>	1 to 10,000 cd/m <sup>2</sup>	6 to 30,000 cd/m <sup>2</sup>	4 to 12,000 cd/m <sup>2</sup>	7 to 25,000 cd/m <sup>2</sup>	
Accuracy guaranteed measurement speed <sup>4)</sup>		Lvxy	AUTO	Measurement luminance range <sup>1)</sup>	0.16 times/sec (> 0.0003 cd/m <sup>2</sup> )	---	---	0.16 times/sec (> 0.0003 cd/m <sup>2</sup> )	---	---	0.16 times/sec (> 0.002 cd/m <sup>2</sup> )	
				1 times/sec (> 0.01 cd/m <sup>2</sup> )	1 times/sec (> 0.01 cd/m <sup>2</sup> )	1 times/sec (> 0.01 cd/m <sup>2</sup> )	1 times/sec (> 0.01 cd/m <sup>2</sup> )	1 times/sec (> 0.04 cd/m <sup>2</sup> )	1 times/sec (> 0.002 cd/m <sup>2</sup> )	1 times/sec (> 0.1 cd/m <sup>2</sup> )	1 times/sec (> 0.004 cd/m <sup>2</sup> )	1 times/sec (> 0.05 cd/m <sup>2</sup> )
	5 times/sec (> 0.15 cd/m <sup>2</sup> )			5 times/sec (> 0.15 cd/m <sup>2</sup> )	5 times/sec (> 0.9 cd/m <sup>2</sup> )	5 times/sec (> 0.15 cd/m <sup>2</sup> )	5 times/sec (> 0.6 cd/m <sup>2</sup> )	5 times/sec (> 0.15 cd/m <sup>2</sup> )	5 times/sec (> 0.9 cd/m <sup>2</sup> )	5 times/sec (> 0.6 cd/m <sup>2</sup> )	5 times/sec (> 1.5 cd/m <sup>2</sup> )	
	20 times/sec (> 2 cd/m <sup>2</sup> )			20 times/sec (> 2 cd/m <sup>2</sup> )	20 times/sec (> 12 cd/m <sup>2</sup> )	20 times/sec (> 2 cd/m <sup>2</sup> )	20 times/sec (> 8 cd/m <sup>2</sup> )	20 times/sec (> 2 cd/m <sup>2</sup> )	20 times/sec (> 12 cd/m <sup>2</sup> )	20 times/sec (> 8 cd/m <sup>2</sup> )	20 times/sec (> 25 cd/m <sup>2</sup> )	
Flicker (Contrast)		20 times/sec	20 times/sec	20 times/sec	20 times/sec	20 times/sec	20 times/sec	20 times/sec	20 times/sec	20 times/sec		
Flicker (JEITA)		0.5 times/sec (at 1 HzPitch), 2.5 times/sec (at 10 HzPitch)	0.5 times/sec (at 1 HzPitch), 2.5 times/sec (at 10 HzPitch)	0.5 times/sec (at 1 HzPitch), 2.5 times/sec (at 10 HzPitch)	0.5 times/sec (at 1 HzPitch), 2.5 times/sec (at 10 HzPitch)	0.5 times/sec (at 1 HzPitch), 2.5 times/sec (at 10 HzPitch)	0.5 times/sec (at 1 HzPitch), 2.5 times/sec (at 10 HzPitch)	0.5 times/sec (at 1 HzPitch), 2.5 times/sec (at 10 HzPitch)	0.5 times/sec (at 1 HzPitch), 2.5 times/sec (at 10 HzPitch)	0.5 times/sec (at 1 HzPitch), 2.5 times/sec (at 10 HzPitch)		
Measurement synchronization mode: NTSC, PAL, EXT, UNIV, INT, MANU (4 ms to 4 s)												
Measurement speed mode: AUTO, LTD, AUTO, SLOW, FAST												
Measurement target (Vertical synchronization frequency)		0.5 to 240 Hz (luminance and chromaticity)	0.5 to 240 Hz (luminance and chromaticity), 0.5 to 130 Hz (flicker)	0.5 to 240 Hz (luminance and chromaticity), 0.5 to 130 Hz (flicker)	0.5 to 240 Hz (luminance and chromaticity)	0.5 to 240 Hz (luminance and chromaticity)	0.5 to 240 Hz (luminance and chromaticity), 0.5 to 130 Hz (flicker)	0.5 to 240 Hz (luminance and chromaticity), 0.5 to 130 Hz (flicker)	0.5 to 240 Hz (luminance and chromaticity)	0.5 to 240 Hz (luminance and chromaticity)		
User calibration memory channel		99 channels										
Interface	Communication	USB2.0, RS-232C										
	Trigger <sup>5)</sup>	IN: 1.8 V / 3.3 to 5 V switching Out: 5 V										
Size (mm)		47 x 47 x 190.5	42 x 42 x 139.7	42 x 42 x 139.7	47 x 47 x 226.5	47 x 47 x 226.2	42 x 42 x 173.5	42 x 42 x 173.5	47 x 47 x 226.5	47 x 47 x 222.9		
Weight		510 g (including mount)	270 g (including mount)	270 g (including mount)	570 g (including mount)	550 g (including mount)	280 g (including mount)	280 g (including mount)	570 g (including mount)	580 g (including mount)		
Power supply		DC 5 V (input from USB bus power line or RS communication connector)										
Operation temperature/humidity range <sup>3)</sup>		10 to 35°C, relative humidity 85% or less with no condensation										
Storage temperature/humidity range		0 to 45°C, relative humidity 85% or less (at 35°C) with no condensation										

\*1: Measured under Konica Minolta's standard light source (6,500K).  
 \*2: Luminance for monochrome is measured when reading of luminance for white is 100 cd/m<sup>2</sup>.  
 \*3: Temperature 23°C/±2°C, relative humidity 40%±10%.  
 \*4: In NTSC synchronization mode using USB with one probe.  
 \*5: Reading fluctuation (compared to reference reading at 23°C, 40% RH): Luminance: ±2% for white; Chromaticity (at 100 cd/m<sup>2</sup>): ±0.002 for white, ±0.003 for monochrome.  
 \*6: "Flicker (CA-310 Mode)" and "XYZ (Wide Frequency Mode)" are mode names for PC Software CA-540. "XYZ (Wide Frequency Mode)" can only be used when no CA-DP40 data processor is connected.

\*7: The spectral sensitivities of probes conforming to CIE 1931-2:2015 are different from those defined for the CIE 1931 color-matching functions; therefore, displayed values for luminance and chromaticity will be different from those calculated based on the CIE 1931 color-matching functions.  
 \*8: Measured under Konica Minolta's standard light source (constant light). If the luminance momentarily greatly exceeds the upper limit, such as with a PWM light source with a small duty cycle, luminances below the upper limit may be shown as too high.  
 \*9: Supports 1.8V switching from products produced in March 2021.  
 \* Unless otherwise specified, specifications are given for conditions established by Konica Minolta.

●KONICA MINOLTA, the Konica Minolta logo and symbol mark are registered trademarks and trademarks of KONICA MINOLTA, INC.  
 ●The specifications and appearance shown herein are subject to change without notice.

ISO Certifications of KONICA MINOLTA, Inc., Sakai Site

	JQA-QMA15888 Design, development, manufacture, manufacturing management, calibration, and service of measuring instruments		JQA-E-80027 Design, development, manufacture, service and sales of measuring instruments
--	---	--	---

ISO 9001 | ISO 14001

# Main Specifications of CA-410 Probes

		CA-P427C	CA-MP410H	
		CIE 170-2: 2015 Supported Probe <sup>7</sup>	Mini Probe	
Measurement area		Ø 27 mm	Ø 10 mm	
Acceptance angle		± 2.5°	± 5°	
Accuracy guaranteed measurement distance		30 ± 10 mm	10 ± 5 mm	
Accuracy guaranteed range <sup>8</sup>		0.001 to 5,000 cd/m <sup>2</sup>	0.1 to 30,000 cd/m <sup>2</sup>	
Luminance	Accuracy (for white) <sup>1, 13</sup>	> 0.0003 cd/m <sup>2</sup>	---	
		> 0.001 cd/m <sup>2</sup>	± 9 %	
		> 0.01 cd/m <sup>2</sup>	± 2 %	
		> 0.1 cd/m <sup>2</sup>	± 1.5 %	
		> 1 cd/m <sup>2</sup>	± 1.5 %	
	Repeatability (2σ) <sup>11</sup>	AUTO	> 0.0003 cd/m <sup>2</sup>	---
		> 0.001 cd/m <sup>2</sup>	10 %	
		> 0.01 cd/m <sup>2</sup>	1 %	
		> 0.1 cd/m <sup>2</sup>	0.4 %	
		> 1 cd/m <sup>2</sup>	2.40 %	
Accuracy guaranteed luminance range <sup>8</sup>		0.01 to 5,000 cd/m <sup>2</sup>	0.1 to 30,000 cd/m <sup>2</sup>	
Chromaticity	Accuracy (for white) <sup>1, 13</sup>	> 0.003 cd/m <sup>2</sup>	---	
		> 0.01 cd/m <sup>2</sup>	± 0.003	
		> 0.1 cd/m <sup>2</sup>	± 0.002	
		> 1 cd/m <sup>2</sup>	± 0.002	
		> 10 cd/m <sup>2</sup>	± 0.002	
	Repeatability (2σ) <sup>11</sup>	AUTO	> 0.003 cd/m <sup>2</sup>	---
		> 0.01 cd/m <sup>2</sup>	0.0035	
		> 0.1 cd/m <sup>2</sup>	0.0015	
		> 1 cd/m <sup>2</sup>	0.0004	
		> 10 cd/m <sup>2</sup>	0.0003	
At 100 cd/m <sup>2</sup> (for monochrome) <sup>12</sup>		> 100 cd/m <sup>2</sup>	± 0.003	
Flicker (CA-310 Mode) <sup>6</sup>				
Flicker (Contrast)	Measurement luminance range <sup>8</sup>	5 to 1,500 cd/m <sup>2</sup>	90 to 18,000 cd/m <sup>2</sup>	
	Measurement target (Flicker frequency)	0.25 to 65 Hz	0.25 to 65 Hz	
	Accuracy	30 Hz, AC/DC 10% sine wave	± 0.4 %	
	Repeatability (2σ)	60 Hz, AC/DC 10% sine wave	± 0.7 %	
Flicker (JEITA)	Measurement luminance range <sup>8</sup>	5 to 1,500 cd/m <sup>2</sup>	90 to 18,000 cd/m <sup>2</sup>	
	Measurement target (Flicker frequency)	0.42 to 65 Hz	0.42 to 65 Hz	
	Accuracy	30 Hz, AC/DC 4% sine wave	± 0.35 dB	
	Repeatability (2σ)	30 Hz, AC/DC 1.2% sine wave	± 0.3 dB	
XYZ (Wide Frequency Mode) <sup>6</sup>	Flicker (Contrast)	Measurement luminance range <sup>8</sup>	5 to 5,000 cd/m <sup>2</sup>	
		Measurement target (Flicker frequency)	0.25 to 200 Hz	
		Accuracy	30 Hz, AC/DC 10% sine wave	
		Repeatability (2σ)	60 Hz, AC/DC 10% sine wave	
	Flicker (JEITA)	Measurement luminance range <sup>8</sup>	5 to 4,500 cd/m <sup>2</sup>	
		Measurement target (Flicker frequency)	0.42 to 200 Hz	
		Accuracy	30 Hz, AC/DC 4% sine wave	
		Repeatability (2σ)	30 Hz, AC/DC 1.2% sine wave	
	Waveform	Measurement luminance range <sup>8</sup>	1 to 5,000 cd/m <sup>2</sup>	
		Sampling frequency	3 kHz	
Accuracy guaranteed measurement speed <sup>14</sup>	Lvxy	AUTO	1 times/sec (> 0.001 cd/m <sup>2</sup> )	
		5 times/sec (> 0.15 cd/m <sup>2</sup> )		
	Flicker (Contrast)	20 times/sec (> 2 cd/m <sup>2</sup> )	20 times/sec (> 12 cd/m <sup>2</sup> )	
		20 times/sec	20 times/sec	
Flicker (JEITA)	0.5 times/sec (at 1 HzPitch),	0.5 times/sec (at 1 HzPitch),		
	2.5 times/sec (at 10 HzPitch)	2.5 times/sec (at 10 HzPitch)		
Measurement synchronization mode		NTSC, PAL, EXT, UNIV, INT, MANU(4 ms to 4 s)		
Measurement speed mode		AUTO, LTD. AUTO, SLOW, FAST		
Measurement target (Vertical synchronization frequency)		0.5 to 240 Hz (luminance and chromaticity),	0.5 to 240 Hz (luminance and chromaticity),	
User calibration memory channel		99 channels		
Interface	Communication	USB2.0, RS-232C		
	Trigger <sup>9</sup>	IN: 1.8V/3.3 to 5V switching Out: 5V		
Size (mm)		42 x 42 x 139.7	42 x 42 x 77	
Weight		270 g (including mount)	200 g (including mount)	
Power supply		DC 5 V (input from USB bus power line or RS communication connector)		
Operation temperature/humidity range <sup>15</sup>		10 to 35°C, relative humidity 85% or less with no condensation		
Storage temperature/humidity range		0 to 45°C, relative humidity 85% or less (at 35°C) with no condensation		

<sup>1</sup>: Measured under Konica Minolta's standard light source (6,500K).

<sup>2</sup>: Luminance for monochrome is measured when reading of luminance for white is 100 cd/m<sup>2</sup>.

<sup>3</sup>: Temperature 23°C/±2°C, relative humidity 40%±10%

<sup>4</sup>: In NTSC synchronization mode using USB with one probe

<sup>5</sup>: Reading fluctuation (compared to reference reading at 23°C, 40% RH): Luminance: ±2% for white; Chromaticity (at 100 cd/m<sup>2</sup>): ±0.002 for white, ±0.003 for monochrome

<sup>6</sup>: "Flicker (CA-310 Mode)" and "XYZ (Wide Frequency Mode)" are mode names for PC Software CA-S40. "XYZ (Wide Frequency Mode)" can only be used when no CA-DP40 data processor is connected.

<sup>7</sup>: The spectral sensitivities of probes conforming to CIE 170-2:2015 are different from those defined for the CIE 1931 color-matching functions; therefore, displayed values for luminance and chromaticity will be different from those calculated based on the CIE 1931 color-matching functions.

<sup>8</sup>: Measured under Konica Minolta's standard light source (constant light). If the luminance momentarily greatly exceeds the upper limit, such as with a PWM light source with a small duty cycle, luminances below the upper limit may be shown as too high.

<sup>9</sup>: Supports 1.8V switching from products produced in March 2021.

<sup>10</sup>: Unless otherwise specified, specifications are given for conditions established by Konica Minolta.

## Probe Dimensions (unit: mm)

CA-VP427A Ø27 Advanced High Sensitivity Probe

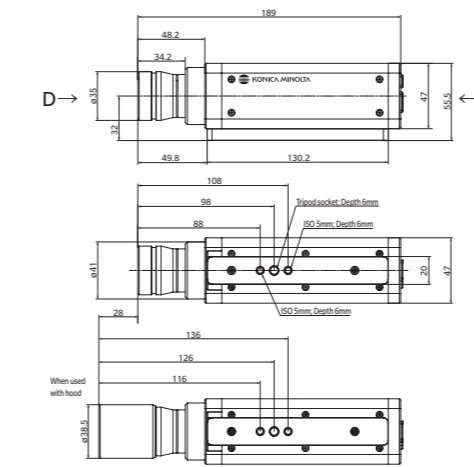

CA-P427 Ø27 Normal Probe  
CA-P427H Ø27 High Luminance Probe  
CA-P427C Ø27 Normal Probe

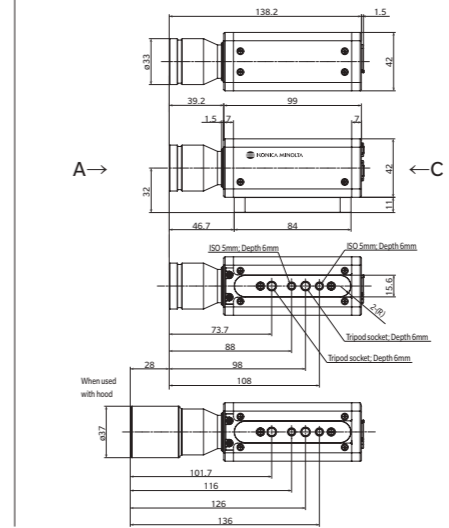

CA-VP410A Ø10 Advanced High Sensitivity Probe

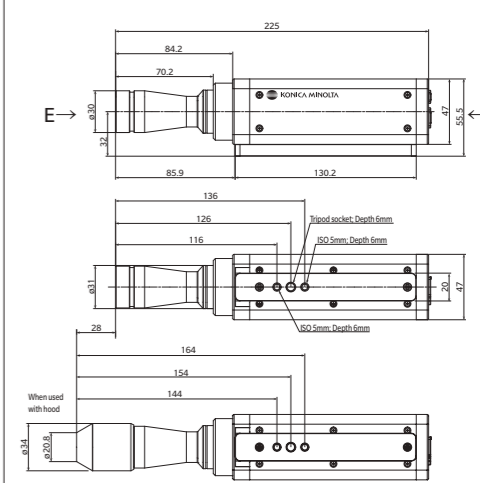

CA-VP410T Ø10LWD Probe (200 mm)

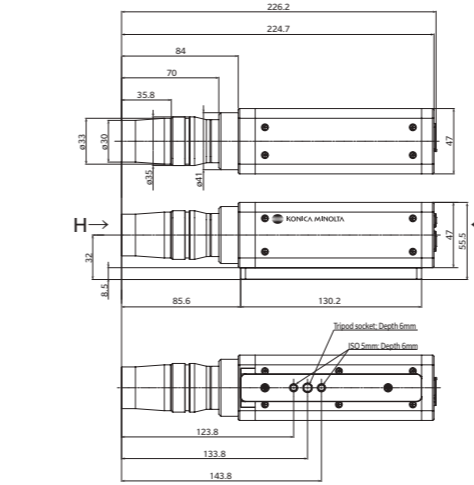

CA-P410 Ø10 Normal Probe  
CA-P410H Ø10 High Luminance Probe

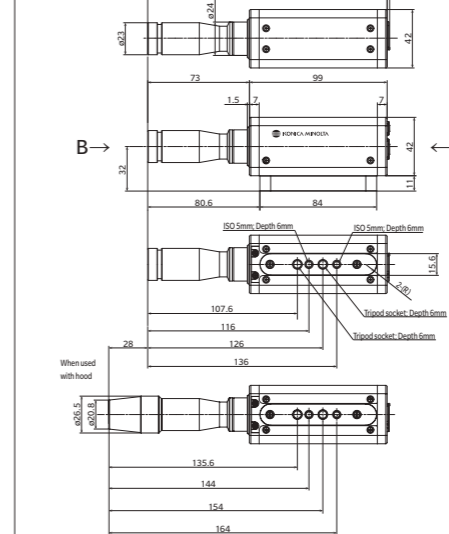

CA-MP410H Ø10 Mini High Luminance Probe

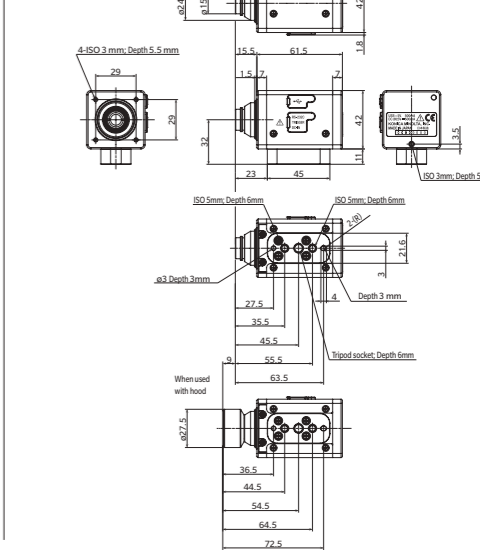

CA-VP404 Ø4 Small Spot Probe

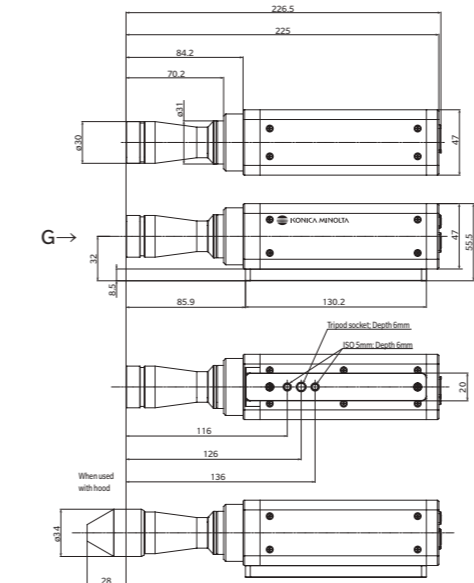

CA-VP402 Ø2 Small Spot Probe

