



KONICA MINOLTA

Display Color Analyzer

CA-410

High-speed, high-accuracy color analyzer that meets the measurement needs of today's ever-evolving displays

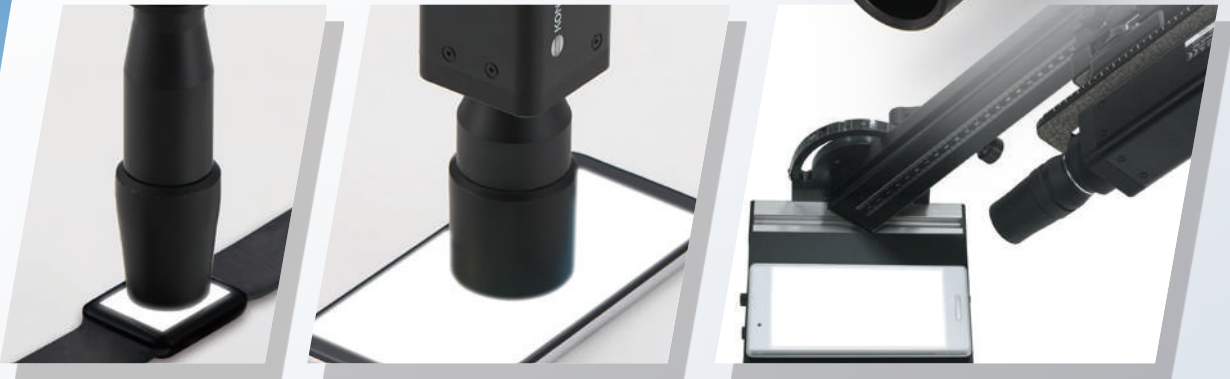

4 key features for measuring

1

Accuracy guaranteed from super-low to high luminance

High-performance sensors and circuitry design combine to realize a wide accuracy-guaranteed luminance range that stretches from super-low to high emissions. This enables the CA-410 to meet the requirements for accurate measurement and tuning of chromaticity and gamma characteristics of OLED and HDR displays which require super-low luminance measurements. Moreover, the CA-410 can be paired with a lineup of high-luminance probes for measuring backlit modules equipped with new technologies like Mini-LEDs.

NEW The newly added CA-VP427A and CA-VP410A Advanced High-Sensitivity Probes offer a guaranteed accuracy range that begins from a super-low luminance of 0.0003 cd/m².

Measurable luminance range examples

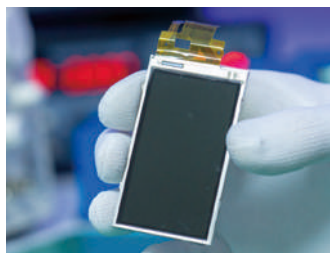

OLED for mobile device: 0.001 - 500 cd/m²

Ø27 CA-VP427 Advanced High Sensitivity Probe
Accuracy-guaranteed luminance measurement range
0.0003 - 5,000 cd/m²



HDR display 0.01 - 2,000 cd/m²

Ø27 CA-P427 probe
Accuracy-guaranteed luminance measurement range
0.001 - 5,000 cd/m²



Backlight module: 20,000 cd/m²

Ø27 CA-P427H high-luminance probe
Accuracy-guaranteed luminance measurement range
0.01 - 30,000 cd/m²

Main probe lineup



Advanced High-Sensitivity Probes
CA-VP410A/CA-VP427A

Normal Probes
CA-P410/427

2

High accuracy comparable to spectroradiometers in chromaticity measurements

The CA-410 features highly accurate XYZ filters that push its spectral sensitivity close to the CIE 1931 color-matching functions*. Moreover, because the calibration light source replicates the emission spectrum of LED displays, tristimulus chromaticity measurements can yield a high level of accuracy comparable to a spectroradiometer. This allows users to more accurately measure and tune the chromaticity and white balance of displays that have a wide color gamut.

*The spectral response of the CIE170-2: 2015 compatible probe CA-P427C is close to that standard's color-matching functions for the 2° observer.

Spectral sensitivity of the CA-410 and calibration light source emission spectrum

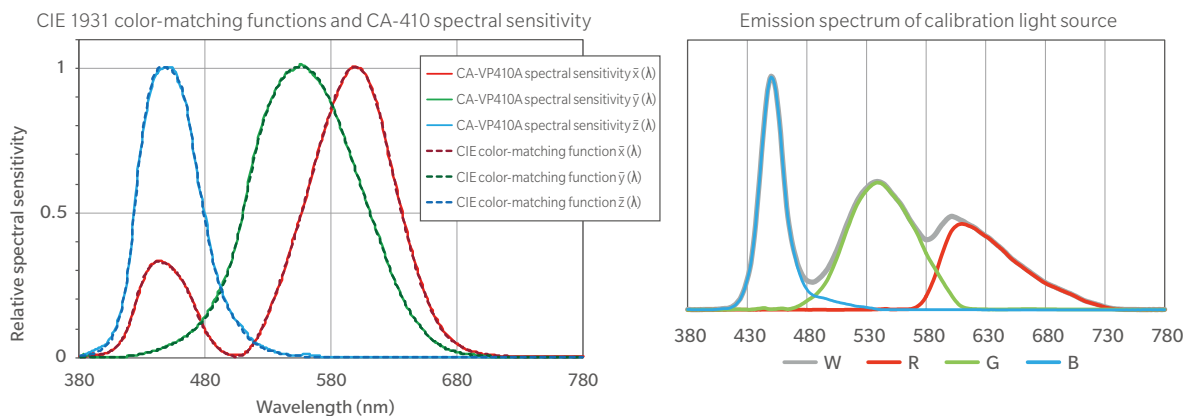

* Example using Advanced High Sensitivity Probe CA-VP410A (Typical for CA-VP410 Series)

3 High-speed measurements for enhanced productivity

Owing to high sensor sensitivity and high-speed computing, measurements with the CA-410 are fast in a way that shortens the time needed to conduct multiple measurements for luminance and chromaticity evaluation and adjustment such as for gamma testing. For even faster speed performance, the CA-410 offers LTD. AUTO mode that increases measurement speed while keeping the same or better accuracy than the predecessor CA-310. Also, Single-Frame mode which allows users to set the shortest integration time for synchronized measurements has been added. It is designed to improve productivity in processes where measurement speed is critical, such as inline color adjustments of OLEDs.

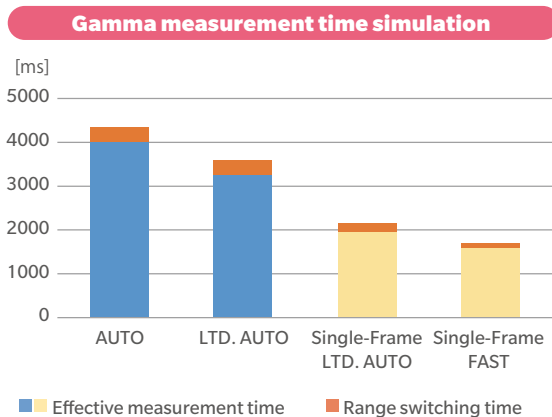
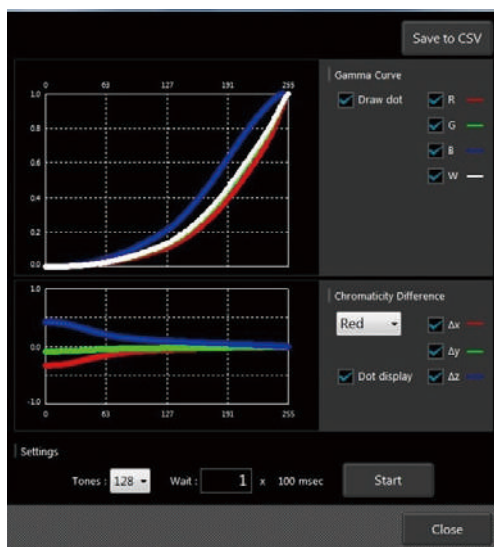

Probe: CA-P427
 Measurement synchronization: NTSC
 Integration time: Double-Frame, Single-Frame*
 Gamma measurement (64 tones) at 0.01 - 500 cd/m²
 Display drive time excluded
 * Accuracy and repeatability may be reduced when using Single-Frame in some cases.

4 Designed for integration into automatic systems

The CA-410 is designed for integration and use in automatic systems. Features include a motorized zero-calibration shutter, synchronization detection function, and direct probe-PC connection which allows full functionality with USB bus power. Both RS-232C and USB ports are provided, and when using USB, the virtual COM port allows quick and easy connection to probes without the need to install drivers. For convenience when integrating the CA-410 into automatic systems developed for predecessor models CA-210/310, the basic communication commands of CA-410 are kept the same. Also, CA-SDK2 (Software development kit for the CA-410) includes as standard a COM registration tool which makes it possible to easily use the CA-410 with programs created for CA-210/310 using the previous CA-SDK. And various cables for incorporation into systems are available as optional accessories.

NEW Supports low-voltage external synchronization signal (1.8V) suitable for automatic synchronization measurement of small displays.

* From products produced after March 2021.

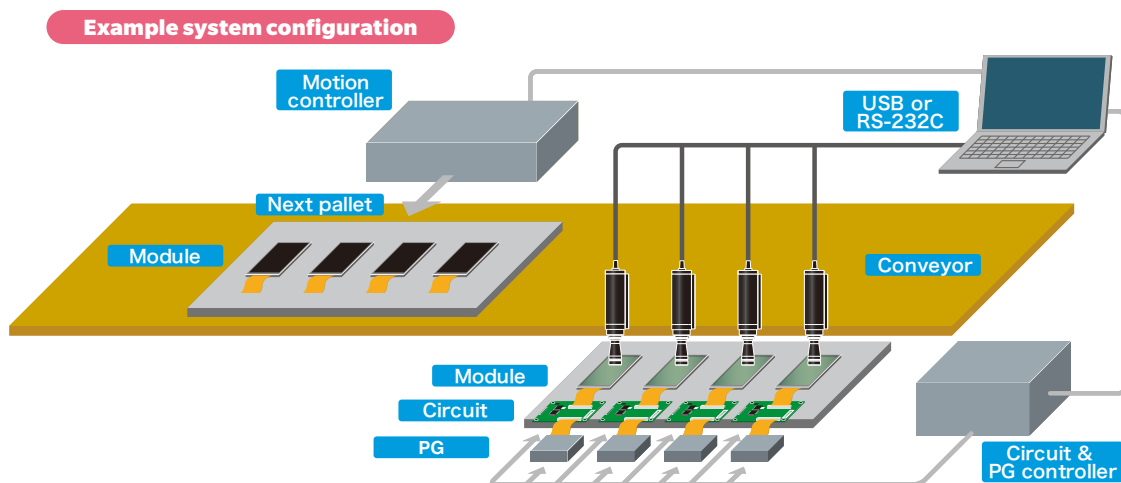

Probes for measuring various

Ø27 mm measurement area

Applicable display size:

5 inches and above

High sensitivity CA-VP427A



Normal CA-P427 High luminance CA-P427H



The measurement area of these probes is suitable for measuring large smartphones, in-vehicle displays, PC monitors, TVs and other large-size displays. Users can choose from the CA-VP427A Advanced High-Sensitivity Probe which offer high-speed measurements with accuracy guaranteed from super-low levels of luminance, or opt for the CA-P427H that can measure luminances as high as 30,000 cd/m².

<Specifications>

Measurement area: Ø27 mm
 Acceptance angle: ± 2.5°
 Accuracy guaranteed measurement distance: 30 mm ± 10 mm
 Accuracy guaranteed range for luminance measurements
 CA-VP427A 0.0003 - 5,000 cd/m²
 CA-P427 0.001 - 5,000 cd/m²
 CA-P427H 0.01 - 30,000 cd/m²
 Accuracy guaranteed luminance range for chromaticity measurements
 CA-VP427A 0.003 - 5,000 cd/m²
 CA-P427 0.01 - 5,000 cd/m²
 CA-P427H 0.1 - 30,000 cd/m²

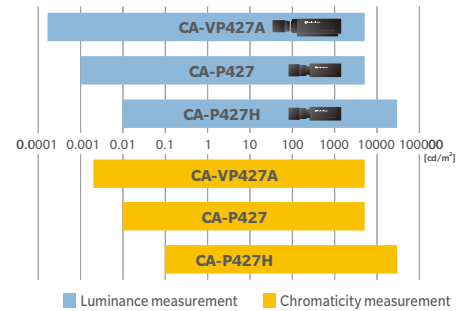

Ø10 mm measurement area

Applicable display size:

Approx. 2 - 10 inches

High sensitivity CA-VP410A



Normal CA-P410 High luminance CA-P410H



These probes have a measurement area suitable for measuring smart watches, small smartphones, in-vehicle displays and other small-size displays. There are three models to choose from, starting with the CA-VP410A Advanced High-Sensitivity Probe which offer high-speed measurements with accuracy guaranteed from super-low levels of luminance, the CA-P410 Normal Probe with its wide accuracy-guaranteed luminance range, or the CA-P410H that can measure luminance as high as 30,000 cd/m².

<Specifications>

Measurement area: Ø10 mm
 Acceptance angle: ± 5° (CA-VP410A ± 8.5°)
 Accuracy guaranteed measurement distance: 30 mm ± 5 mm
 Accuracy guaranteed range for luminance measurements
 CA-VP410A 0.0003 - 3,000 cd/m²
 CA-P410 0.002 - 10,000 cd/m²
 CA-P410H 0.1 - 30,000 cd/m²
 Accuracy guaranteed luminance range for chromaticity measurements
 CA-VP410A 0.003 - 3,000 cd/m²
 CA-P410 0.01 - 10,000 cd/m²
 CA-P410H 0.1 - 30,000 cd/m²

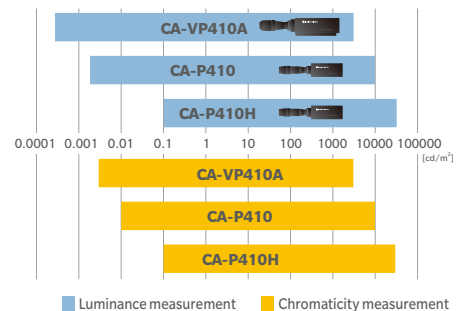

<0-point calibration time>

0-point calibration with the CA-VP427A, CA-VP410A and CA-VP402 takes about 10 sec. With all other probes, it is about 3 sec.

Probe specification tables can be downloaded from the below address.

<https://www.konicaminolta.com/instruments/download/catalog/display/index.html>



kinds of displays

Ø2, Ø4 mm measurement area

Applicable display size:

2 inches and below



These probes have small measurement areas which are suitable for measurement of micro OLEDs, smart watches, etc. Although the measurement area is small, the probes can take display measurements from low luminance levels at high speed and high accuracy, suitable for applications like gamma adjustments. The lineup consists of 2 models: CA-VP402 Small Spot Probe with Ø2 mm measurement area and CA-VP404 Small Spot Probe with Ø4 mm measurement area.

* Since CA-VP402 has an imaging optical system, when measuring devices with large pixel pitch, interference between the sensor fiber and the display pixels may adversely affect measurement repeatability.

<Specifications>

Measurement area: CA-VP402 Ø2.1 mm; CA-VP404 Ø4 mm

Acceptance angle: CA-VP402 ± 10°; CA-VP404 ± 8.5°

Accuracy guaranteed measurement distance:

CA-VP402 28 mm ± 2 mm

CA-VP404 30 mm ± 2 mm

Accuracy guaranteed range for luminance measurements

CA-VP402 0.002 - 25,000 cd/m²

CA-VP404 0.004 - 12,000 cd/m²

Accuracy guaranteed luminance range for chromaticity measurements

CA-VP402 0.02 - 25,000 cd/m²

CA-VP404 0.04 - 12,000 cd/m²

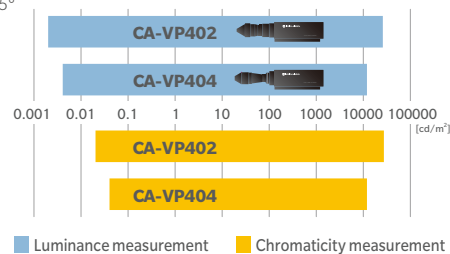

Long working distance probe

Multiple angle measurements, evaluation of angular viewing characteristics



CA-VP410T Ø10 mm LWD probe (200mm) is suitable for multi-angle measurements of OLED for smartphones and in-vehicle displays, and also evaluation of viewing angle characteristics of curved displays. It is also a viable choice when distances must be kept from measurement targets to avoid collisions in automatic measuring systems.

<Specifications>

Measurement area: Ø10 mm

Acceptance angle: ± 4°

Accuracy guaranteed measurement distance:

200 mm ± 2 mm

Accuracy guaranteed range for luminance measurements:

0.004 - 12,000 cd/m²

Accuracy guaranteed luminance range for chromaticity measurements:

0.04 - 12,000 cd/m²

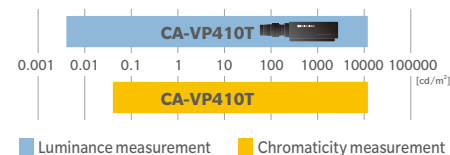

Cables

Cables for connecting probes with PC are available as accessories.

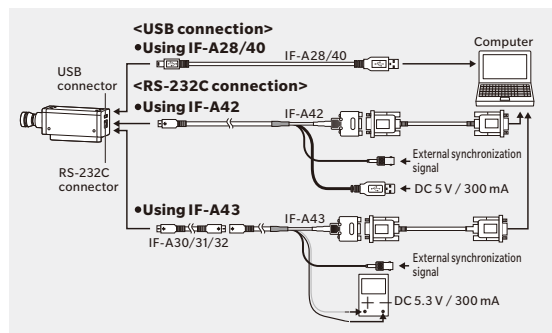

<USB connections>

USB cable (2 m)

USB cable (5 m)

BNC conversion cable

<RS-232C connections>

Conversion cable

Conversion cable (Extension)

IF-A28 (Communication + Power) Included with probe as a standard accessory

IF-A40 (Communication + Power)

IF-A35 (External synchronization signal)

IF-A42 (Communication + USB Power + External synchronization signal)

IF-A43 (Communication + Power line + External synchronization signal)

IF-A43 is used together with RS cable for probe-DP connection

IF-A30 (2m) / IF-A31 (5m) / IF-A32 (10m)

Full software support

CA-S40 supports not only Windows10/11 but also Mac OS, and allows users to connect the probe to a computer and perform measurements from there. In addition to basic operations like conducting luminance, chromaticity and flicker measurements and saving results, logging live data of emission fluctuations via a waveform function is also possible. Moreover, the application incorporates other features that users will find useful in various measurement operations, including automatic detection of the display's emission frequency and using it for internal synchronization.



(Luminance/Chromaticity measurement)



(JEITA flicker measurement)

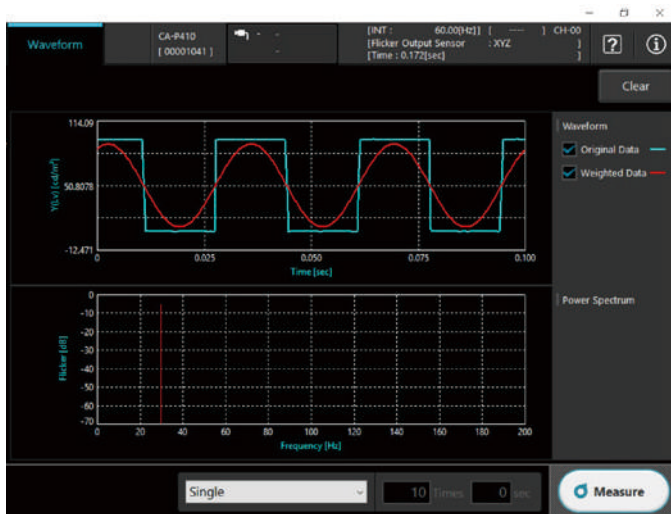

(Waveform window)



(Frequency sensitivity characteristic setting)

<Supported products>

All models of CA-410 probes, Data Processor CA-DP40

<Measurement items>

Luminance

Chromaticity (xy, u'v', Tduv, dominant wavelength, excitation purity)

Waveform

Flicker (JEITA, VESA), user-settable frequency sensitivity (IEC62341-6-3 sensitivity sample included)

Source: IEC 62341-6-3:2017/COR1:2019

<Other features>

Automatic frequency detection of measurement target

Setting of the shortest integration time (Single-Frame) for synchronized measurement

* Click the link below to download CA-S40/CA-SDK2 free of charge.

Software downloads require an input of customer information.

<https://www.konicaminolta.com/instruments/download/software/display/index.html>



Easy-to-operate Data Processor CA-DP40

Data Processor CA-DP40 takes the "easy-to-operate" feature of the CA Series to new heights.

With automatic zero calibration that allows measurement to start immediately after the power is turned ON, an easy-to-view 7-inch color display, multilingual support and a lithium ion battery (sold separately) that makes the unit portable, the CA-DP40 obtains measurement data quickly and reliably, making it convenient for on-the-spot measurements for R & D applications.

Moreover, a maximum of 10 probes can be connected for multi probe measurements.

* The CA-VP410A and CA-VP427A cannot connect to the CA-DP40.



CA-DP40 dimensions
(Units : mm)

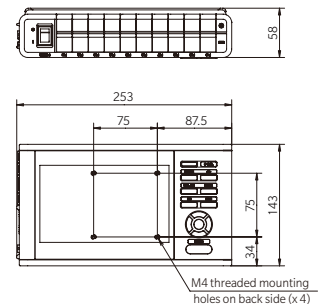

CA-DP40

Main Specifications of PC Software CA-S40

<System requirements>	
OS	Windows® 10 Pro 64-bit Windows® 11 Pro macOS® Catalina / Big Sur / Monterey • The hardware of the computer system to be used must meet or exceed the greater of the recommended system requirements for the compatible OS being used or the following specifications.
CPU	Intel® Core™ i series or equivalent Apple Silicon M1 Chip or equivalent (Apple Silicon native support)
Memory	4 GB or more
Hard disk drive	More than 500 MB of available space Out of the above, there must be at least 50 MB of available space on the system drive (drive where the OS is installed)
Display	Capable of at least 1,440 × 900 pixels/ High color, 16-bit
Others	USB port for installing from flash drive USB port (2.0 or higher) for connecting measuring instruments
<Controllable instruments>	
CA-410 Data Processor	CA-DP40
CA-410 Probes	CA-P427 / P427H / P427C / P410 / P410H / P410C* / MP410 / MP410H / VP427* / VP427A / VP410* / VP410A / VP402 / VP404 / VP410T * are sales discontinued models
<Languages>	
Display language	English

Main Specifications of Data Processor CA-DP40

Display range	Luminance	0.0001 to 30,000 cd/m ²
	Chromaticity	Displayed in 4 digits
	Flicker (Contrast) (JEITA)	0.00 to 999.99 % To 2 decimal places
Display	7-inch color LCD WVGA	
Display items	L _v x y (ΔL _v Δx Δy) L _v u' v' (ΔL _v Δu' Δv') L _v Tcp duv (ΔL _v ΔTcp duv) X Y Z (ΔX ΔY ΔZ) L _v λd Pe (ΔL _v Δλd ΔPe) Flicker (Contrast) Flicker (JEITA)	
Measurement data storage channels	100 CH	
Data logging function	Available	
Display languages	English, Simplified Chinese, Traditional Chinese, Korean, Japanese	
Interface	For computer, etc.	USB 2.0 RS-232C Ethernet *[Optional] Bluetooth® (module required)
	For probes	Mini-DIN 8-pin cable (for RS communication) USB (for USB communication)
	Sync signal input	BNC connector (with trigger input)
Multi probe connection	10 probes (maximum)	
Operation temperature/humidity range	10 to 35°C, relative humidity 85% or less with no condensation	
Storage temperature/humidity range	0 to 45°C, relative humidity 85% or less (at 35°C) with no condensation	
Power	AC Adapter *[Optional] Lithium-Ion Battery (removable)	
Battery life	3 hours (when one probe is connected)	
Size	253 (W) x 58 (H) x 143 (D) mm	
Weight	1.6 kg	
Accessories	Standard	AC Cable RS Cable for Probe-DP (2 m) IF-A30 AC Adapter AC-A312F
	Optional	USB Cable for DP-PC (2 m) IF-A34 RS Cable for Probe-DP IF-A31 (5 m), IF-A32 (10 m) Lithium-Ion Battery CM-A223 Bluetooth Module CM-A219 Carrying Case CA-A01

System Diagram

[Probe]

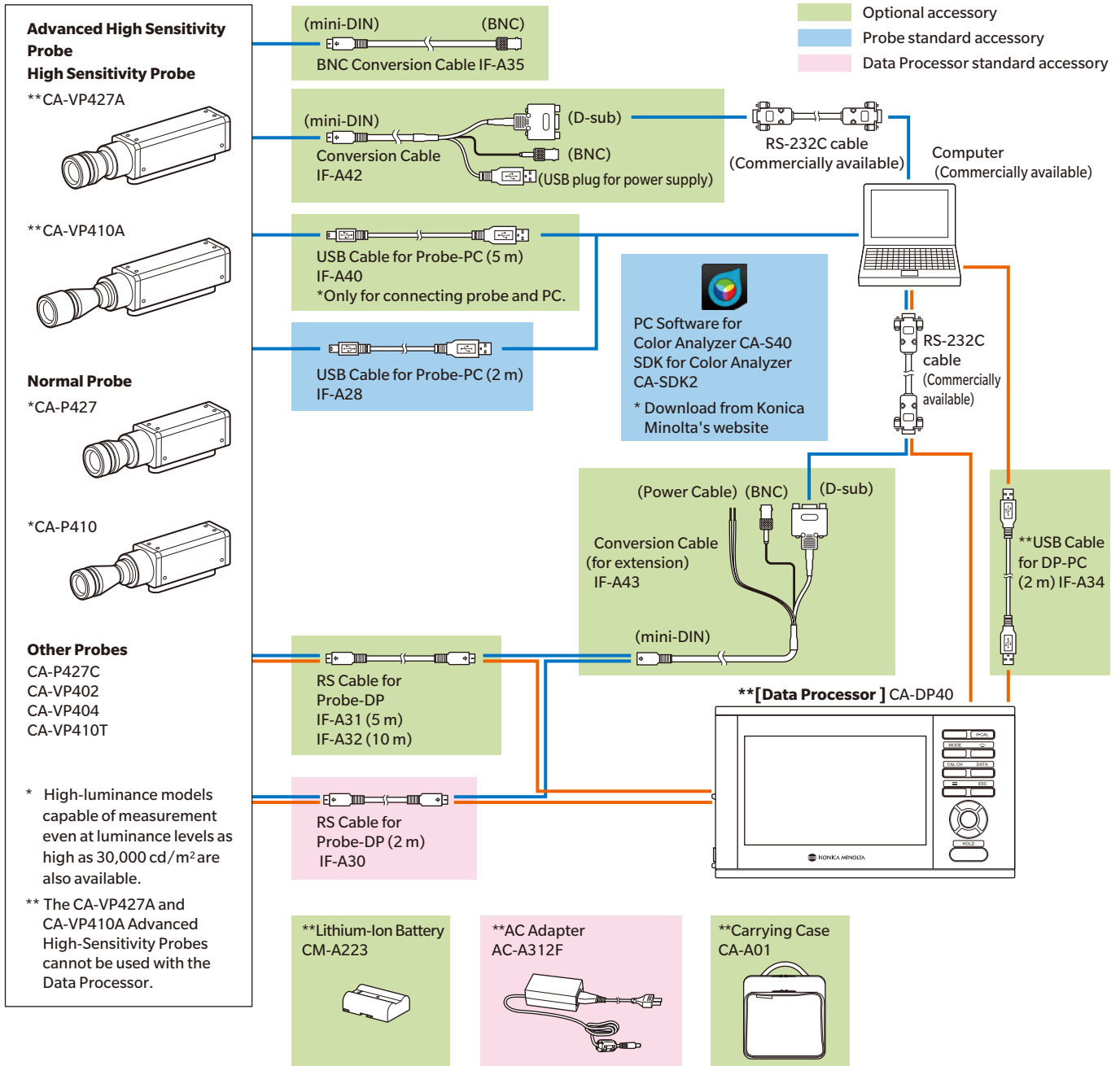

- Windows® is a trademark or registered trademark of Microsoft Corporation in the USA and other countries.
- macOS® is a registered trademark of Apple Inc. in the USA and other countries.
- Intel® Core™ is a trademark or registered trademark of Intel Corporation in the USA and other countries.
- Other company names and product names used herein are trademarks or registered trademarks of their respective companies.
- Bluetooth® is a registered trademark of Bluetooth SIG, Inc. and is used under license agreement.
- Screens shown are for illustration purposes only.
- The specifications and appearance shown herein are subject to change without notice.

SAFETY PRECAUTIONS

For correct use and for your safety, be sure to read the instruction manual before using the instrument.

- Always connect the instrument to the specified power supply voltage. Improper connection may cause a fire or electric shock.

ISO Certifications of KONICA MINOLTA, Inc., Sakai Site

JQA-QMA15888
Design, development, manufacture/
manufacturing management, calibration, and
service of measuring instruments

JQA-E-80027
Design, development,
manufacture, service and sales
of measuring instruments

KONICA MINOLTA, INC.	Osaka, Japan		
Konica Minolta Sensing Americas, Inc.	New Jersey, U.S.A.	PHONE: (888)473-2656 (in USA), +1(201)236-4300 (outside USA)	FAX: +1(201)785-2480 E-Mail: service.us@konicaminolta.com
Konica Minolta Sensing Europe B.V.	European HQ/ BENELUX German Office French Office UK Office Italian Office Swiss Office Nordic Office Polish Office	Nieuwegein, Netherlands München, Germany Roissy CDG Cedex, France Warrington, United Kingdom Cinisello Balsamo, Italy Dietikon, Switzerland VÄSTRA FRÖLUNDA, Sweden Wrocław, Poland	PHONE: +31(0)30 248-1193 +49(0)89 4357 156 0 +33(0)1 80 11 10 70 +44(0)1925 467300 +39 02849488.00 +41(0)43 322-9800 +46(0)31 7099464 +48(0)71 73452-11
Konica Minolta (CHINA) Investment Ltd.	SE Sales Division Beijing Office Guangzhou Office Chongqing Office Qingdao Office Wuhan Office Shenzhen Office Xiamen Office	Shanghai, China Beijing, China Guangzhou, China Chongqing, China Shandong, China Hubei, China Shenzhen, China Xiamen, China	PHONE: +86-(0)21-6057-1089 +86-(0)10-8522 1551 +86-(0)20-3826 4220 +86-(0)23-6773 4988 +86-(0)532-8079 1871 +86-(0)27-6885 0586 +86-(0)755-2868 7535 +86-(0)592-7107 399
Konica Minolta Sensing Singapore Pte. Ltd.	Singapore	PHONE: +65 6563-5533	E-Mail: ssg@gcp.konicaminolta.com
Konica Minolta Sensing Korea Co., Ltd.	Korean HQ Cheonan Office	Goyang-si, Korea Cheonan-si, Korea	PHONE: +82(0)2-523-9726 +82(0)41-556-9726
			E-Mail: se.korea@konicaminolta.com se.korea@konicaminolta.com

Addresses and telephone/fax numbers and e-mail address are subject to change without notice.
For the latest contact information, please refer to KONICA MINOLTA Worldwide Offices web page:

<https://konicaminolta.com/instruments/network>