

KONICA MINOLTA

Display Color Analyzer

CA-500 series



Improved accuracy and reliability,
and faster measurement
for ultra-low luminance

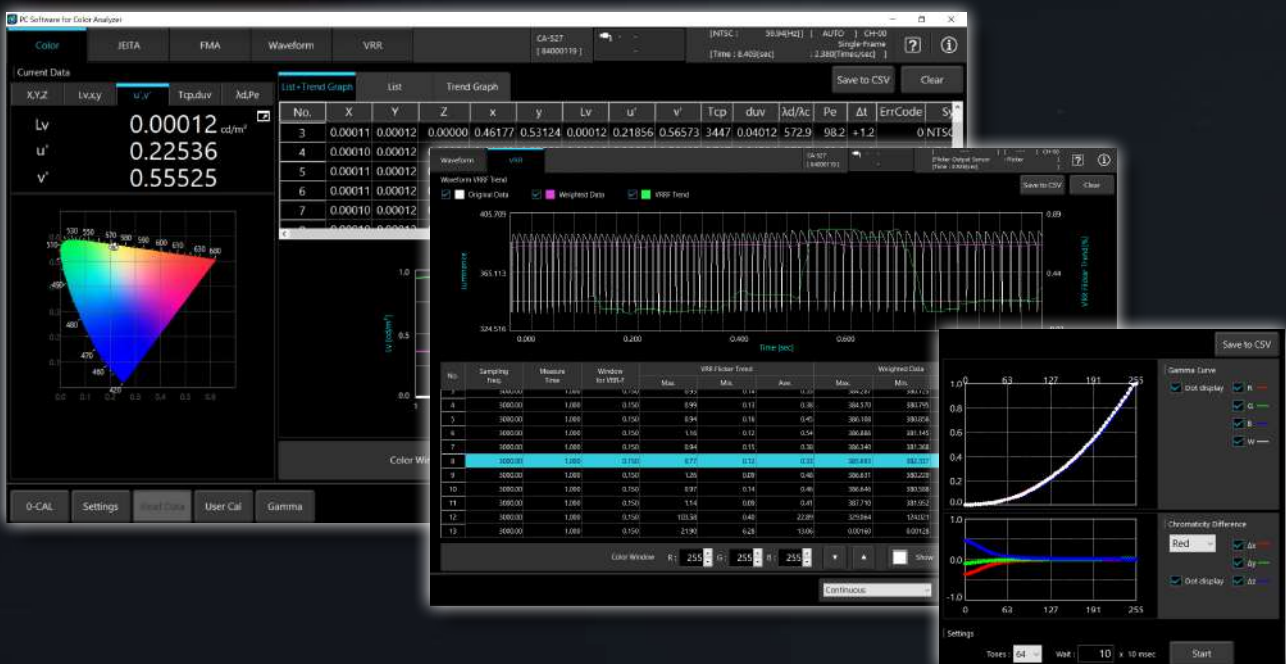

The Standard in Measuring Color & Light



Giving Shape to Ideas

Four industry-leading features to satisfy the needs of the latest display evaluations

1 Expanded accuracy guaranteed range of luminance

The expanded measurement dynamic range, which covers the range from ultra-low to high luminance, achieves a wider range of measurement accuracy and repeatability than the conventional Display Color Analyzer series. This meets the need for more accurate evaluation of luminance and chromaticity required by the latest displays such as OLED and micro-LED displays, which have higher contrast ratios and wider color gamut.

Accuracy guaranteed luminance range

Probe model	CA-527	CA-VP427A (conventional model)
Measurement area	Ø27 mm	Ø27 mm
Luminance measurement	0.0001 to 10,000 cd/m ²	0.0003 to 5,000 cd/m ²
Chromaticity measurement	0.001 to 10,000 cd/m ²	0.003 to 5,000 cd/m ²

Probe model	CA-510	CA-VP410A (conventional model)
Measurement area	Ø10 mm	Ø10 mm
Luminance measurement	0.0002 to 20,000 cd/m ²	0.0003 to 3,000 cd/m ²
Chromaticity measurement	0.002 to 20,000 cd/m ²	0.003 to 3,000 cd/m ²

*CA-500 series, with a wide acceptance angle (CA-527: ±8.5°, CA-510: ±15°), is ideal for measuring displays whose angular characteristics within the acceptance angle range show little deviation and remain consistent across gray levels.



Recommended Measurement Instrument for DisplayHDR™ and DisplayHDR™ True Black Certification
*Please contact us for further information about the recommended models.

2 Even faster measurements

The latest optical design used in the CA-500 series allows for significantly shorter low-luminance measurement times than the models in the conventional Display Color Analyzer series. This can help solve issues related to takt time improvement at display production line and the realm of high-definition display R&D.

Accuracy guaranteed luminance measurement time*

Probe model	CA-527	CA-VP427A (conventional model)	CA-510	CA-VP410A (conventional model)
Luminance measurement time	0.0001 cd/m ² : 1 sec	0.0003 cd/m ² : 6 sec	0.0002 cd/m ² : 1 sec	0.0003 cd/m ² : 6 sec

* When using AUTO mode.

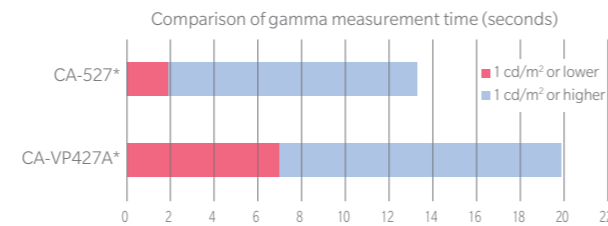

* Actual measurement conditions :OLED display (approximately 6 inches), 700 cd/m² (white), 0.002 cd/m² (black), 64 gradations, W_γ measurement "AUTO" mode used (accuracy guaranteed mode)

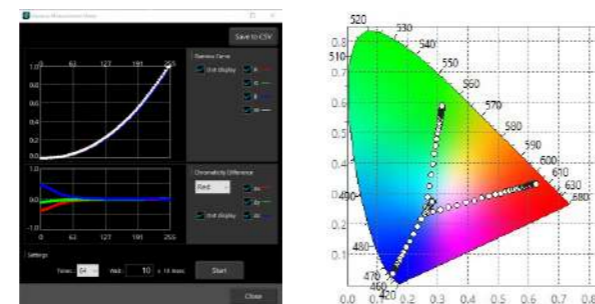

(Gamma measurement)

3 Significantly improved waveform measurement performance

The CA-500 series can measure lower-luminance areas at a higher sampling rate than the models in the conventional Display Color Analyzer series. This allows for more accurate capture of the emission waveforms of displays, which have become increasingly complex with recent technological trends in displays, such as OLED displays evolving toward even higher contrast ratios and the latest micro-LED displays employing the dynamic drive system.



(Waveform measurement screen)

Specification of waveform measurement

Probe model	CA-527 [mode: Flicker]	CA-VP427A (conventional model)	CA-510 [mode: Flicker]	CA-VP410A (conventional model)
Measurement luminance range	0.1 to 10,000 cd/m ²	1 to 3,000 cd/m ²	0.2 to 20,000 cd/m ²	1 to 2,500 cd/m ²
Sampling frequency	200 kHz Changeable	3 kHz	200 kHz Changeable	3 kHz
Repeatability (2σ)	1.8%	(no listed specification)	1.8%	(no listed specification)

Example data of low luminance (around 0.01 cd/m²) waveform measurement

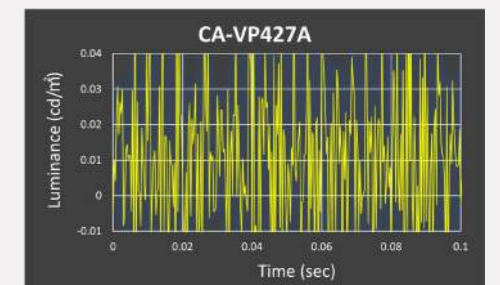
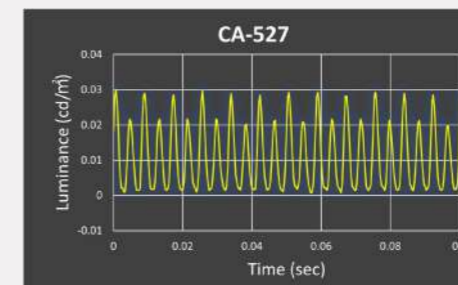

4 Variable refresh rate (VRR) flicker measurement

This model provides a new flicker measurement function related to VRR*, the latest index for flicker evaluation, in addition to the high-performance flicker measurement function using the JEITA, VESA, and FMA methods as provided by the conventional Display Color Analyzer series. With the industry's best flicker measurement performance, the CA-500 series sets a new standard while meeting the need for quality evaluation of the latest displays pushing the boundaries in advanced video quality and power saving.

* For details on VRR-Flicker, please refer to page 5 of this catalog.



(VRR-Flicker measurement screen)

Flicker measurement specification

	Probe model	CA-527 [mode: Flicker]	CA-VP427A (conventional model)	CA-510 [mode: Flicker]	CA-VP410A (conventional model)
Contrast Flicker	Measurement luminance range	0.5 to 10,000 cd/m ²	5 to 3,000 cd/m ²	1 to 20,000 cd/m ²	15 to 3,000 cd/m ²
	Accuracy (60 Hz, AC/DC 10% sine wave)	± 0.3 %	± 1.7 %	± 0.3 %	± 0.7 %
	Repeatability (2σ)	0.3%	1.6%	0.3%	0.3%
JEITA Flicker	Measurement luminance range	0.5 to 10,000 cd/m ²	5 to 3,000 cd/m ²	1 to 20,000 cd/m ²	15 to 2,000 cd/m ²
	Accuracy (30 Hz, AC/DC 1.2% sine wave)	± 0.35 dB	± 0.35 dB	± 0.35 dB	± 0.35 dB
	Repeatability (2σ, 30 Hz, AC/DC 1.2% sine wave)	0.3 dB	1.4 dB	0.3 dB	1.3 dB
VRR-Flicker	Measurement luminance range	0.5 to 10,000 cd/m ²	5 to 3,000 cd/m ²	1 to 20,000 cd/m ²	5 to 3,000 cd/m ²
	Accuracy (1 to 120 Hz, AC/DC 10% sine wave)	± 0.3 %	± 0.22 %	± 0.3 %	± 0.08 %
	Repeatability (2σ, 1 to 120 Hz, AC/DC 10% sine wave)	0.3 %	0.32 %	0.3 %	0.06 %

Full software support

PC Software CA-S40 can be downloaded from Konica Minolta website free of charge. The software connects the CA-500 series connects to a computer for measurement, allowing you to check measurement data, trend graphs, and waveforms.

* Click the link below to download CA-S40/CA-SDK2 free of charge.

Software downloads require input of customer information.
<https://www.konicaminolta.com/instruments/download/software/display/index.html>



Luminance and chromaticity measurement

- Synchronization frequency can be detected and set.
- Listed measurement results can be saved in .csv format or copied and pasted into a spreadsheet.
- Data can be displayed on graphs in various color spaces such as xy and u'v'
- ✔ Even low-luminance data below 0.1 cd/m² can be observed on trend graphs.



(Luminance and chromaticity measurement screen)

Gamma measurement

- The Color Window can be controlled by CA-S40 to automatically perform gamma measurements.
- ✔ An ideal gamma curve (gamma value) can be set as a target for comparison with actual measurement results.
- ✔ Approximate gamma values can be calculated from actual measurement results and displayed.

Flicker measurement

- In addition of FMA (contrast) and JEITA methods, flicker measurement align with IEC 62341-6-3 can also be performed by combining various weighting factors.
- VRR-Flicker, a new flicker evaluation index, can be measured.
- ✔ SVM measurement is possible utilizing the CA-527's capability for high-speed sampling over 20 kHz*
 *SVM is defined in CIE TN006:2016 and CIE 249:2022 standards and is gaining attention as an index for eye protection.

Waveform measurement

- The number of samples to measure for showing the display emission waveform can be set as desired.
- Waveforms can be converted and displayed by applying weighting factors.
- ✔ Specific parts of the waveform or spectral graphs can be zoomed in on for detailed observation.

* ✔ : New features available in CA-S40 Ver.2.1 and later

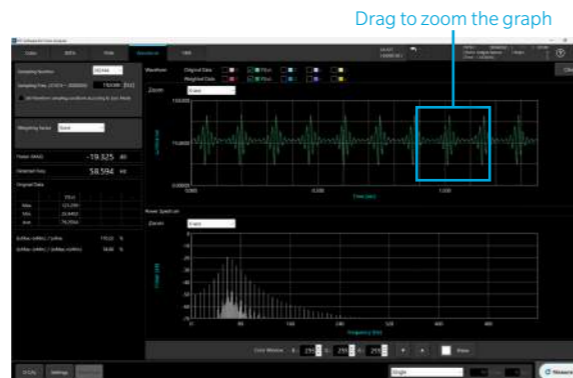

(Waveform measurement screen)

<System requirements for CA-S40 (Ver.2.2)>

OS	Windows® 11 Pro, macOS® Sonoma, macOS® Sequoia * The required PC system configuration is the recommended configuration for the operating system above or the specifications below (whichever is more advanced).
Computer	Computer equipped with Intel Core i series, or equivalent processor, or a computer equipped with an Apple Silicon M1 chip, or equivalent processor (Apple silicon native support)
Memory	More than 4 GB
Storage	More than 500 MB of available space Out of the above, there must be at least 50 MB of available space on the system drive (drive where the OS is installed)
Display resolution	Display that supports at least 1,440 × 900 pixels and 16-bit colors
Other	USB 2.0 or above required to connect the instrument
Display languages	Display: English only

Flicker measurement for VRR displays

With the growing adoption of Variable Refresh Rate (VRR) technology and advancements in power-saving, there is an increasing need to evaluate flicker that occurs during frequency switching, as well as discrete and complex flicker with longer occurrence intervals. Traditional flicker measurement methods, such as the contrast (FMA) method and the JEITA method designed for LCDs, may not accurately capture flicker phenomena specific to VRR displays as perceived by the human eye. To address this, Konica Minolta developed the VRR-Flicker measurement method and integrated it into our Color Analyzers to enable evaluations highly correlated with visual perception.

Effectiveness Comparison with Conventional Methods

Purpose		Method		
		VRR-Flicker	JEITA	FMA
Conventional Use	LCD Vcom Adjustment			✔
	Periodic Waveform Flicker (20 to 65 Hz)	✔	✔	
New Use	Periodic Waveform Flicker (Low to High Frequency)	✔		
	Aperiodic Flicker	✔		
	Flicker Due to Complex Waveforms	✔		

New method - VRR-Flicker

The JEITA method, which enables measurements based on the TCSF of the human eye, has been widely used in applications requiring high visual correlation. However, due to its methodological characteristics—(1) reliance on Fourier transforms (e.g., FFT), (2) limited sensitivity to low-frequency components in TCSF, and (3) calculation of flicker values based only on the highest frequency component—it is only suitable for measuring simple and periodic waveforms in the 20 to 65 Hz range, as shown in the table above. The VRR-Flicker method overcomes these limitations by incorporating an updated TCSF and advanced calculation method. While maintaining the ability to accurately measure traditional periodic and static flicker, it also enables precise evaluation of newly emerging flicker patterns that require assessment.

Conference Presentation

We delivered a presentation on VRR-Flicker technology at IDW'21*.

Paper "Flicker Calculation Method for Dynamic Refresh Rate Display"
 URL: <https://doi.org/10.36463/idw.2021.0690>

*The 28th International Display Workshops



VRR-Flicker Measurement

The PC Software CA-S40 enables the emission waveform of the target display ("Original data"), the perceived luminance waveform ("Weighted data"), and the VRR-Flicker value to be easily measured and obtained.



Additionally, "VRR-Flicker Trend," which represents the variation of the VRR-Flicker value over time, can be acquired. This provides insight into how flicker is perceived by the human eye and serves as a useful tool for evaluating flicker quality.

Probes Supporting the Function

This feature is available for all CA-410 series* and CA-500 series probes.

CA-410 series probes provide sufficient performance for evaluating flicker as perceived by the human eye. The CA-500 series probe goes further, enabling accurate measurement of emission waveforms and flicker even for OLED displays at low luminance, where emission waveforms change rapidly.

* The CA-410 firmware must be version 1.4 or later.

	CA-527	CA-VP427A
VRR-Flicker measurement luminance range	≥ 0.5 cd/m ²	≥ 5 cd/m ²
Sampling frequency	Up to 200 kHz	3 kHz
Aliasing prevention function	Yes	No

CA-SDK2 can be used to obtain the same data as CA-S40 for seamless integration of VRR-Flicker measurement and inspection into production lines.

Specifications

		CA-527	CA-510		
Measurement area		Ø 27 mm	Ø 10 mm		
Acceptance angle		± 8.5°	± 15°		
Accuracy guaranteed measurement distance		30 ± 5 mm	30 ± 5 mm		
Luminance	Accuracy guaranteed luminance range *7		0.0001 to 10,000 cd/m ²	0.0002 to 20,000 cd/m ²	
	Accuracy (for white)*1, *3	> 0.0001 cd/m ²	± 9 %	± 9 %	
		> 0.0002 cd/m ²	± 9 %	± 9 %	
		> 0.0005 cd/m ²	± 3 %	± 3.5 %	
		> 0.001 cd/m ²	± 2 %	± 3 %	
		> 0.01 cd/m ²	± 1.5 %	± 2 %	
	Repeatability (2σ)*1	> 0.1 cd/m ²	± 1.5 %	± 1.5 %	
		> 0.0001 cd/m ²	10 %	---	
		> 0.0002 cd/m ²	---	10 %	
		> 0.0005 cd/m ²	2 %	3 %	
> 0.001 cd/m ²		1 %	2 %		
Chromaticity	Accuracy guaranteed luminance range *7		0.001 to 10,000 cd/m ²	0.002 to 20,000 cd/m ²	
	Accuracy (for white)*1, *3	> 0.001 cd/m ²	± 0.003	---	
		> 0.002 cd/m ²	---	± 0.003	
		> 0.01 cd/m ²	± 0.002	± 0.002	
		> 0.01 cd/m ²	0.0030	---	
> 0.02 cd/m ²		---	0.0030		
Repeatability (2σ)*1	> 0.01 cd/m ²	0.0009	0.0012		
	> 0.1 cd/m ²	0.0004	0.0005		
	> 1 cd/m ²	0.0002	0.0003		
	> 10 cd/m ²	0.0002	0.0002		
	Flicker (Contrast)	Flicker *6	Measurement luminance range*7		0.5 to 10,000 cd/m ²
Measurement target (Flicker frequency)			0.25 to 65 Hz	0.25 to 65 Hz	
Accuracy			30 Hz, AC/DC 10% sine wave	± 0.3 %	± 0.3 %
			60 Hz, AC/DC 10% sine wave	± 0.3 %	± 0.3 %
Repeatability (2σ) 20 to 65 Hz, AC/DC 10% sine wave			0.3 %	0.3 %	
XYZ *6		Measurement luminance range*7		0.5 to 10,000 cd/m ²	1 to 20,000 cd/m ²
		Measurement target (Flicker frequency)		0.25 to 200 Hz	0.25 to 200 Hz
		Accuracy	30 Hz, AC/DC 10% sine wave	± 1.5 %	± 1.5 %
			60 Hz, AC/DC 10% sine wave	± 2.2 %	± 2.2 %
		Repeatability (2σ) 20 to 65 Hz, AC/DC 10% sine wave		1.6 %	1.6 %
Flicker (JEITA)	Flicker *6	Measurement luminance range*7		0.5 to 10,000 cd/m ²	1 to 20,000 cd/m ²
		Measurement target (Flicker frequency)		0.42 to 65 Hz	0.42 to 65 Hz
		Accuracy	30 Hz, AC/DC 4% sine wave	± 0.35 dB	± 0.35 dB
			30 Hz, AC/DC 1.2% sine wave	± 0.35 dB	± 0.35 dB
		Repeatability (2σ)		0.1 dB	0.1 dB
	XYZ *6	Measurement luminance range*7		0.5 to 8,500 cd/m ²	1 to 14,000 cd/m ²
		Measurement target (Flicker frequency)*8		0.42 to 200 Hz	0.42 to 200 Hz
		Accuracy	30 Hz, AC/DC 4% sine wave	± 0.35 dB	± 0.35 dB
			30 Hz, AC/DC 1.2% sine wave	± 0.35 dB	± 0.35 dB
		Repeatability (2σ)		0.4 dB	0.4 dB
Waveform	Flicker *6	Measurement luminance range*7		0.1 to 10,000 cd/m ²	0.2 to 20,000 cd/m ²
		Sampling frequency		200 kHz Changeable	200 kHz Changeable
		Repeatability (2σ)		1.8 %	1.8 %
	XYZ *6	Measurement luminance range*7		0.1 to 10,000 cd/m ²	0.2 to 19,000 cd/m ²
		Sampling frequency		3 kHz Changeable	3 kHz Changeable
		Repeatability (2σ)		13 %	13 %
VRR-Flicker	Flicker	Measurement luminance range*7		0.5 to 10,000 cd/m ²	1 to 20,000 cd/m ²
		Sampling frequency*8		200 kHz Changeable	200 kHz Changeable
		Measurement target (Flicker frequency)*8		0.01 to 100 [Hz]	0.01 to 100 [Hz]
	Accuracy	1 to 120 Hz, AC/DC 10% sine wave	± 0.3 %	± 0.3 %	
		1 to 120 Hz, AC/DC 10% sine wave	0.3 %	0.3 %	
	Repeatability (2σ)		0.3 %	0.3 %	
Accuracy guaranteed measurement speed *4	Lvxy	AUTO	1 time/sec (> 0.0001 cd/m ²)	1 time/sec (> 0.0002 cd/m ²)	
			5 times/sec (> 0.012 cd/m ²)	5 times/sec (> 0.02 cd/m ²)	
	Flicker (Contrast)		20 times/sec	20 times/sec	
	Flicker (JEITA/VESA)		0.5 times/sec (at 1 HzPitch), 2.5 times/sec (at 10 HzPitch)	0.5 times/sec (at 1 HzPitch), 2.5 times/sec (at 10 HzPitch)	
VRR-Flicker		Sampling frequency: 3 kHz		0.7 times/sec (at 1s Obs.)	0.7 times/sec (at 1s Obs.)
Measurement target (Vertical synchronization frequency)		0.5 to 240 Hz (luminance and chromaticity)		0.5 to 240 Hz (luminance and chromaticity)	
Power supply		DC 5 V (input from USB bus power line or RS communication connector)			
Operating temperature/humidity range*5		10 to 35°C, relative humidity 85% or less with no condensation			
Storage temperature/humidity range		0 to 45°C, relative humidity 85% or less (at 35°C) with no condensation			

*1: Measured under Konica Minolta's standard light source (6,500 K).
 *2: Luminance for monochrome is measured when reading of luminance for white is 100 cd/m².
 *3: Temperature 23°C/±2°C, relative humidity 40% ± 10%
 *4: In NTSC [DOUBLE FRAME] synchronization mode using USB with one probe. Measured using a Konica Minolta-designated PC (with PC and probe directly connected, using the supplied measurement software).
 *5: Reading fluctuation (compared to reference reading at 23°C, 40% RH): Luminance: ± 2% for white; Chromaticity (at 100 cd/m²): ± 0.002 for white, ± 0.003 for monochrome
 *6: "Flicker" and "XYZ" are mode names for PC Software CA-S40.
 *7: Measured under Konica Minolta's standard light source (constant light). If the luminance momentarily greatly exceeds the upper limit, such as with a PWM light source with a small duty cycle, luminances below the upper limit may be shown as too high.
 *8: The listed values are for use with CA-S40 or CA-SDK2.

* Unless otherwise specified, specifications are given for conditions established by Konica Minolta.

System Diagram

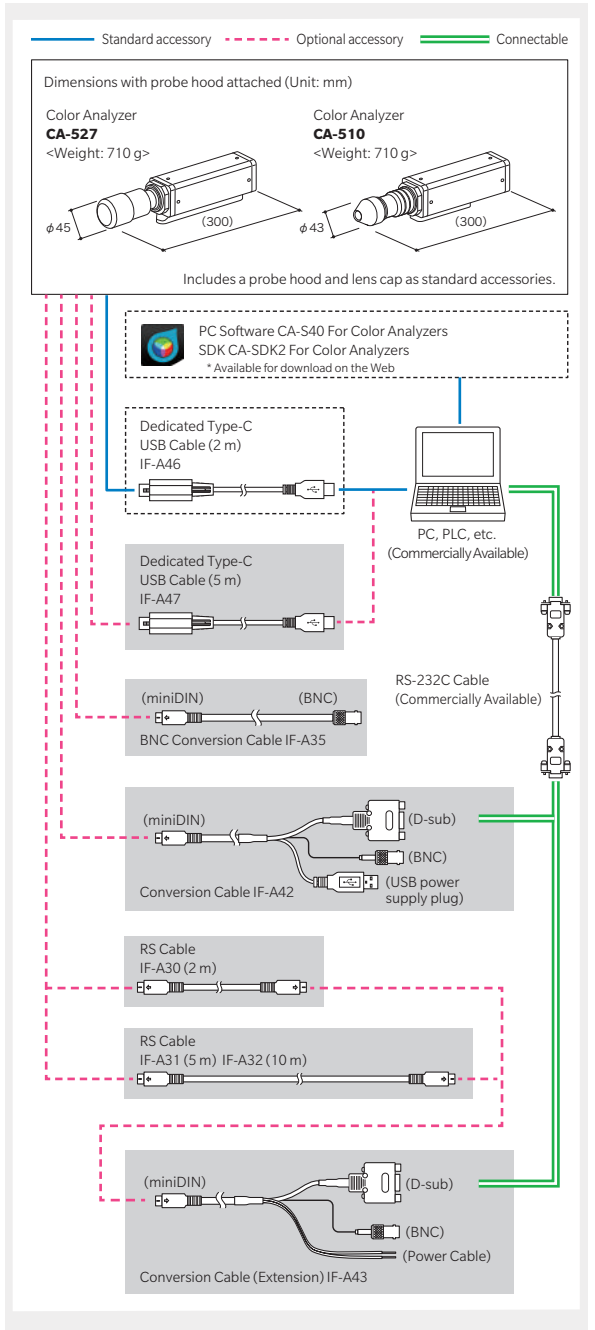

- KONICA MINOLTA, the KONICA MINOLTA logo and symbol marks and the "Giving Shape to Ideas" slogan are trademarks or registered trademarks of Konica Minolta, Inc.
- Windows® is a trademark or registered trademark of Microsoft Corporation in the U.S.A. and other countries.
- "Apple" and "macOS" are registered trademarks of Apple Inc. in the U.S.A. and other countries.
- Other company and product names included herein are trademarks or registered trademarks of their respective companies.
- Screenshots are partly composites with inserts.
- The specifications and product appearance shown here may be changed without notice.
- This catalog provides information about products and services intended for use by businesses. The prices shown do not include consumption tax.

SAFETY PRECAUTIONS

For correct use and for your safety, be sure to read the instruction manual before using the instrument.

- Always connect the instrument to the specified power supply voltage. Improper connection may cause a fire or electric shock.

ISO Certifications of KONICA MINOLTA, Inc., Sakai Site

JQA-QMA15888
Design, development, manufacture/
manufacturing management, calibration, and
service of measuring instruments

JQA-E-80027
Design, development,
manufacture, service and sales
of measuring instruments

CONTACT US-Global Network

<https://www.konicaminolta.com/instruments/network/>