

# SPECTROPHOTOMETER CM-3700A

## INSTRUCTION MANUAL



Before using this instrument,  
please read this manual.



KONICA MINOLTA

# Safety Symbols

The following symbols are used in this manual or CM-3700A to prevent accidents which may occur as a result of incorrect use of the instrument.



Denotes an instruction regarding a safety warning or note.  
Read the instruction carefully to ensure safe and correct use.



Denotes an instruction regarding the risk of electric shock.  
Read the instruction carefully to ensure safe and correct use.



Denotes an instruction regarding the risk of fire.  
Read the instruction carefully to ensure safe and correct use.



Denotes a prohibited action.  
This action must never be performed.



Denotes an instruction.  
This instruction must be strictly adhered to.



Denotes a prohibited action.  
Never disassemble the instrument.



Denotes an instruction.  
Be sure to disconnect the AC adapter from the AC outlet.



This symbol indicates A.C.



This symbol indicates D.C.



This symbol indicates class II protection against electric shock.

## Trademarks











- Windows® is a registered trademark of Microsoft Corporation in the United States and other countries.







## Notes on this Manual

- Copying or reproduction of all or part of the contents of this manual without KONICA MINOLTA's permission is strictly prohibited.
- The contents of this manual are subject to change without prior notice.
- Every effort has been made in the preparation of this manual to ensure the accuracy of its contents. However, should you have any questions or find any errors, please contact your retailer or a KONICA MINOLTA-authorized service facility.
- KONICA MINOLTA will not accept any responsibility for consequences arising from the use of the instrument.

# Safety Precautions

To ensure correct use of this instrument, read the following points carefully and adhere to them. After you have read this manual, keep it in a safe place where it can be referred to anytime a question arises.

|  <b>WARNING</b>   |   | (Failure to adhere to the following points may result in death or serious injury.) |  |
|--|---|--|--|
|  <p>Do not use the instrument in places where flammable or combustible gases (gasoline, etc.) are present. Doing so may cause a fire.</p>   |  <p>Do not disassemble or modify the instrument or the AC adapter. Doing so may cause a fire or electric shock.</p>  |  |  |
|  <p>Always use the AC adapter supplied as a standard accessory or the optional AC adapter, and connect it to an AC outlet of the rated voltage and frequency. If an AC adapter other than those specified by KONICA MINOLTA is used, it may result in damage to the unit, fire or electric shock.</p> |  <p>Take special care not to allow liquid or metal objects to enter the instrument. Doing so may cause a fire or electric shock. Should liquid or metal objects enter the instrument, turn the power OFF immediately, disconnect the AC adapter plug from the AC outlet, and contact the nearest Konica Minolta-authorized service facility.</p> |  |  |
|  <p>If the instrument will not be used for a long time, disconnect the AC adapter plug from the AC outlet. Accumulated dirt or water on the prongs of the AC adapter's plug may cause a fire and should be removed.</p>   |  <p>The instrument should not be operated if it is damaged or the AC adapter is damaged, or if smoke or odd smells occur. Doing so may cause a fire. In such situations, turn the power OFF immediately, disconnect the AC adapter plug from the AC outlet and contact the nearest Konica Minolta-authorized service facility.</p>               |  |  |
|  <p>Do not forcibly bend, twist, or pull the AC adapter power cable. Do not scratch or alter the power cable or place heavy objects on it. Doing so may damage the power cable and cause a fire or electric shock.</p>  |  <p>Always hold the plug itself when disconnecting the AC adapter plug from the AC outlet. Pulling on the power cable may damage it and cause a fire or electric shock.</p>  |  |  |
|  <p>Insert the power plug fully and securely. Incomplete inserting may cause fire or electric shock.</p>  |  <p>Do not insert or disconnect the AC adapter plug from an AC outlet with wet hands. Doing so may cause electric shock.</p>   |  |  |

|  <b>CAUTION</b>  |  | (Failing to adhere to the following points may result in injury or damage to the instrument or other property.) |  |
|---|--|---|--|
|  <p>Do not perform measurement with the specimen measuring port directed towards your eyes. Doing so may damage your eyes.</p>   |  <p>Do not place the instrument on an unstable or sloping surface. Doing so may result in its falling or overturning, causing injury. Be careful not to drop the instrument when carrying it.</p> |   |  |
|  <p>Be careful not to get your hand caught in the openable section of the instrument. Doing so may result in injury. When carrying the instrument, fix it with tape, etc. to prevent the transmittance specimen chamber cover from opening and closing. Doing so may result in your hand caught by the cover and result in injury.</p> |  <p>Make sure that the AC outlet is located near the instrument and that the AC adapter plug can be connected to and disconnected from the AC outlet easily.</p>                                  |   |  |
|   |  <p>When cleaning, disconnect the power plug. Connecting may cause electric shock.</p>  |   |  |

# INTRODUCTION

This spectrophotometer is designed for spectral measurement of color and color differences in various industries. It can measure both reflected and transmitted color with high accuracy.

## ■ Packing Materials

### General Packing Materials

Keep all packing materials (cardboard box, cushioning material, plastic bags, etc.) in a safe place. The CM-3700A is a precision measuring instrument. They can be used to protect the instrument from impact and vibration during shipment to Konica Minolta for maintenance. Should they be lost or damaged, contact the nearest Konica Minolta-authorized service facility.

### Protective cap for the specimen measuring port (integrating sphere opening)

The CM-3700A is delivered with no target mask attached. To protect the specimen measuring port, a protective cap is attached to the specimen measuring port.

This protective cap must be removed before using the CM-3700A.

When you transport the CM-3700A to another place, the protective cap must be attached. Keep the protective cap in a safe place after putting it in the accessory case (CM-A156).

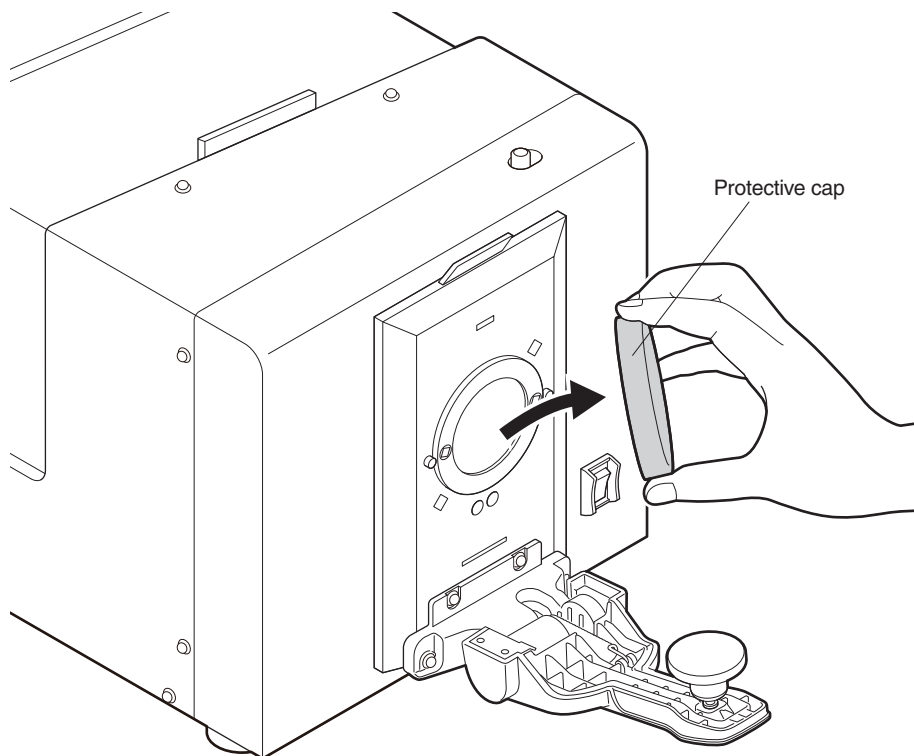

## ■ Notes on Use

Be sure to use this instrument properly. Use of this instrument in ways other than those specified in this manual may result in risk of injury, electric shock, instrument damage, or other problems.

### Operating Environment

- Use the CM-3700A at an ambient temperature between 13°C and 33°C and relative humidity 80% or less (at 33°C) with no condensation. Be sure to use the instrument within this range. Do not use it in areas of rapid temperature changes.
- Do not leave the CM-3700A in direct sunlight or near sources of heat, such as stoves, etc. The internal temperature of the instrument may become much higher than the ambient temperature in such cases.
- Do not use the CM-3700A in areas where dust, cigarette smoke or chemical gases are present. Doing so may cause deterioration in performance or a breakdown.
- Do not use the CM-3700A near equipment which produces a strong magnetic field (such as speakers, etc.).
- The CM-3700A belongs to installation category I products (equipment which is powered by an AC adapter-connected to commercially available power).
- The CM-3700A belongs to pollution degree 2 products (equipment which may cause temporary electrical hazards due to contamination or condensation or products which are used in such an environment).
- Do not use the CM-3700A at altitudes higher than 2,000 m.
- The CM-3700A and the AC adapter supplied as a standard accessory have been designed exclusively for indoor use. They should never be used outdoors because rain or other factors may damage the instrument.

### Measurement

- Make sure no dirt or dust get into the specimen measuring port.
- When using the instrument for long periods of time, the measurement value may change depending on changes in the environment. Therefore, in order to achieve accurate measurements, we recommend that white calibration be done regularly using the White Calibration Plate.

### White Calibration Plate

- The calibration data for the White Calibration Plate was measured at 23°C.  
To achieve the highest accuracy when measuring absolute values (colorimetric values), calibration and measurement should be performed at 23°C.
- Do not allow the White Calibration Plate to get scratched or stained with such as fingerprints.
- Do not move the White Calibration Plate while it has been caught by the sample holder. Doing so may damage the White Calibration Plate.
- When the White Calibration Plate is not in use, be sure to close the cover so that the White Calibration Plate is not exposed to ambient light.

### Target Mask

- Do not touch the Target Mask's inner surface (white-coated surface) by hand, scratch it or make it dirty.
- When not in use, Target Masks should be stored in the accessory case (CM-A156) so that they will not be exposed to ambient light.

### Power Source

- Make sure that the power switch is set to OFF (" I ") when the CM-3700A is not in use.
- Always use the AC adapter supplied as a standard accessory (AC-A308) and connect it to an AC outlet of the rated voltage and frequency.
- Use an AC power supply of the rated supply voltage (within  $\pm 10\%$ ).
- Do not connect the AC adapter to an overloaded electrical circuit. In addition, do not wrap or cover the AC adapter with cloth or other material while in use. Doing so may cause an electric shock or fire.

## **System**

- Do not subject the CM-3700A to strong impact or vibration. Doing so may cause deterioration of performance or breakdown.
- The specimen measuring port and integrating sphere are extremely precise components, and great care should be taken to prevent them getting dirty or exposing them to impacts. When the CM-3700A is not in use, be sure to attach a target mask to the measuring port to prevent entry of foreign matter.
- The CM-3700A may cause interference if used near a television, radio, etc.
- Since the CM-3700A uses a microcomputer, external magnetic noise may cause malfunction. In this case, turn the power OFF, and wait 30 minutes, and then turn it ON again.

## **About Transmittance Measurement**

- Do not spill a specimen or other liquid on the instrument. If any liquid is spilled on the instrument, wipe it off immediately with a soft, dry cloth.

## ■ Notes on Storage

- The CM-3700A should be stored at temperatures between 0°C and 40°C, and at a relative humidity of 80% or less (35°C) without condensation. Do not store the instrument in areas subject to high temperatures, high humidity, sudden changes in temperature, or where freezing or condensation may occur, because these circumstances may cause a breakdown. It is recommended to store the CM-3700A with a drying agent at a temperature around 20°C.
- Do not leave the CM-3700A inside a car such as in the trunk. Otherwise, the temperature and/or humidity may exceed the allowable range for storage during midsummer or midwinter, resulting in a breakdown.
- Keep the packing materials used for shipment and use them to transport the CM-3700A. This protects the instrument from sudden changes in temperature, vibration, and shock.
- Do not store the CM-3700A in areas where dust, cigarette smoke or chemical gases are present. Doing so may cause deterioration in performance or a breakdown.
- Entry of dust into the specimen measuring port will hinder accurate measurement. When the instrument is not in use, you must close the transmittance chamber cover and cover the instrument with the supplied Dust Cover to prevent the entry of dust into the integrating sphere.
- The White Calibration Plate may become discolored if left exposed to light. Therefore, make sure to close the cover when it is not in use so that the White Calibration Plate is not exposed to ambient light during storage.
- The Target Masks may discolor if they are left exposed to light. When they are not in use, keep them in a safe place to prevent exposure to light and to protect them from scratches and dust. And store them in the accessory case (CM-A156).
- Take care not to leave the CM-3700A for a long period of time with a target mask attached. The sample holder may stick to the target mask.
- Be sure to keep all packing materials (cardboard box, cushioning material, plastic bags, etc.). They can be used to protect the instrument during transportation to the service facility for maintenance (re-calibration etc.).

## ■ Notes on Cleaning

- If the CM-3700A becomes dirty, wipe it with a soft, clean dry cloth. Never use solvents such as thinner or benzene.
- If the White Calibration Plate becomes dirty, wipe it with a soft, clean dry cloth. If dirt is difficult to remove, wipe it off with a cloth dampened with commercially-available lens cleaning solution. Then remove the solution with a cloth dampened with water, and leave the plate to dry.
- If the inner surface (white-coated surface) of the Target Masks, or the inside of the integrating sphere, get dirty, contact a Konica Minolta-authorized service facility.
- Should the CM-3700A break down, do not try to disassemble and repair it by yourself. Contact a Konica Minolta-authorized service facility.

## ■ Disposal Method

- Make sure that the CM-3700A and its accessories and packing materials are either disposed of or recycled correctly in accordance with local laws and regulations.

# CONTENTS

|                                 |          |
|---------------------------------|----------|
| <b>Safety Precautions .....</b> | <b>1</b> |
| <b>INTRODUCTION .....</b>       | <b>2</b> |
| Packing Materials .....         | 2        |
| Notes on Use.....               | 3        |
| Notes on Storage.....           | 5        |
| Notes on Cleaning.....          | 5        |
| Disposal Method.....            | 5        |
| <b>CONTENTS.....</b>            | <b>6</b> |

## Using the CM-3700A

|   |           |
|---|-----------|
| <b>Standard Accessories.....</b>  | <b>8</b>  |
| <b>Optional Accessories.....</b>  | <b>9</b>  |
| <b>System Diagram .....</b>   | <b>10</b> |
| <b>Names and Functions of Parts.....</b>  | <b>11</b> |
| <b>Measurement Procedure.....</b>   | <b>12</b> |
| Flow of Preparation and Measurement .....   | 12        |
| <b>Connecting a Personal Computer.....</b>  | <b>13</b> |
| <b>Connecting the AC Adapter.....</b>   | <b>14</b> |
| <b>Turning Power ON and OFF.....</b>  | <b>15</b> |
| <b>Attaching a Target Mask.....</b>   | <b>16</b> |
| Notes on Use of Target Mask .....   | 16        |
| <b>Calibration of Reflectance and<br/>transmittance measurements.....</b>               | <b>17</b> |
| Calibration for Reflectance Measurements .....  | 17        |
| White calibration data .....  | 17        |
| Calibration for Transmittance Measurements .....  | 17        |
| 100% calibration data .....   | 17        |
| Performing calibration.....   | 18        |
| <b>Attaching the Zero Calibration Box .....</b>   | <b>19</b> |
| Notes on Use of Zero Calibration Box .....  | 19        |
| <b>Attaching the White Calibration Plate..</b>  | <b>20</b> |
| Notes on Use of White Calibration Plate .....   | 20        |
| Updating White Calibration Data .....   | 20        |
| <b>Attaching the Transmittance Zero<br/>Calibration Plate (Optional Accessory).....</b> | <b>21</b> |
| Notes on Use of Transmittance Zero Calibration Plate .....                              | 21        |
| <b>Performing 100% calibration .....</b>  | <b>22</b> |
| Setting up instrument for 100% calibration to air....                                   | 22        |
| Setting up instrument for 100% calibration to water....                                 | 22        |

|   |           |
|---|-----------|
| <b>Setting a Specimen .....</b>                             | <b>23</b> |
| Reflectance measurement .....                               | 23        |
| The sample holder for measuring the reflectance ...         | 24        |
| About opacity measurements .....                            | 24        |
| Transmittance measurements .....                            | 25        |
| The transmittance chamber for transmittance measurement.... | 26        |
| About haze measurements.....                                | 26        |
| <b>Cleaning the CM-3700A and Accessories...27</b>           |           |
| Zero Calibration Box and White Calibration Plate..          | 27        |
| Target Mask .....   | 27        |
| Inside Integrating Sphere .....                             | 27        |
| Receiving Window .....                                      | 28        |
| <b>ERROR MESSAGE.....</b>                                   | <b>29</b> |
| <b>TROUBLESHOOTING GUIDE.....</b>                           | <b>31</b> |

## Explanations

|  |           |
|--|-----------|
| <b>Illumination/Observation System.....</b>            | <b>34</b> |
| Measuring Reflected Colors .....                       | 34        |
| Measuring Transmitted Colors.....                      | 34        |
| <b>Illumination and Measurement Areas..</b>            | <b>35</b> |
| Target Mask .....                                      | 35        |
| Measurement Area.....                                  | 35        |
| <b>System Configuration .....</b>                      | <b>35</b> |
| <b>Fluorescent Measurement.....</b>                    | <b>36</b> |
| UV Adjustment .....                                    | 36        |
| WHEN FLUORESCENT CALIBRATION IS<br>PERFORMED .....     | 36        |
| WHEN FLUORESCENT CALIBRATION IS NOT<br>PERFORMED ..... | 36        |
| <b>Dimensions .....</b>                                | <b>37</b> |
| <b>Specifications .....</b>                            | <b>38</b> |





## **Using the CM-3700A**

# Standard Accessories

## White Calibration Plate CM-A154

Used to perform white calibration for measurement of reflectance and to perform measurement of transmittance. A CD-ROM containing white calibration data and software for writing the white calibration data is supplied with this accessory.

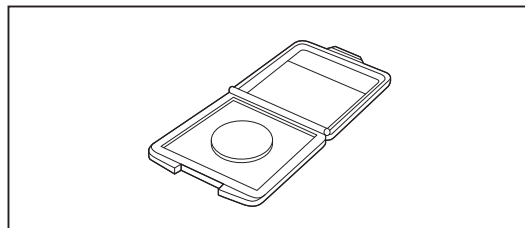

## Target Mask CM-A91 CM-A92 CM-A93

Used to change the illumination area (measurement aperture) according to the specimen. Measurement and illumination (aperture area at specimen surface) areas for each target mask are as follows:

- CM-A91 (SAV) :  $3 \times 5$  mm /  $5 \times 7$  mm
- CM-A92 (MAV) :  $\varnothing 8$  mm /  $\varnothing 11$  mm
- CM-A93 (LAV) :  $\varnothing 25.4$  mm /  $\varnothing 30$  mm

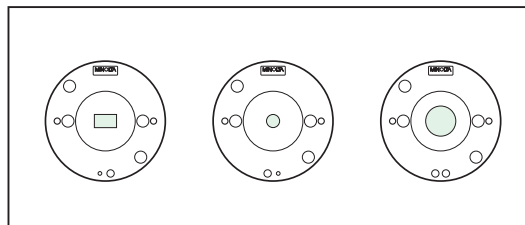

## Zero Calibration Box CM-A155

Used to perform zero calibration for measurement of reflectance and to perform haze measurement at measurement of transmittance.

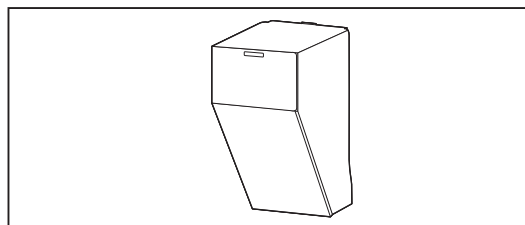

## AC Adapter AC-A308

Used to supply power from an AC outlet to the CM-3700A.  
Input: 100 to 240 V  $\sim$  50/60 Hz  
Output: 8 V  $\equiv$  1.5 A  
Plug design:  $\oplus$   $\ominus$  Center-negative

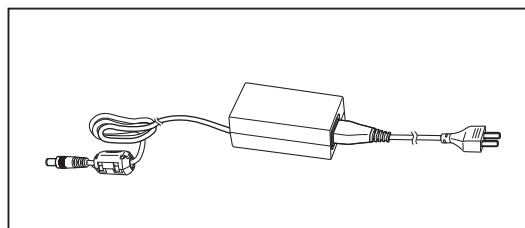

## USB Cable (3 m) IF-A21

Used to connect the instrument to a personal computer (PC).

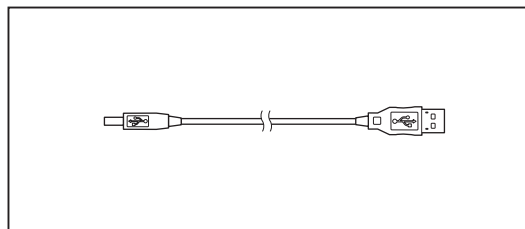

## Accessory Case CM-A156

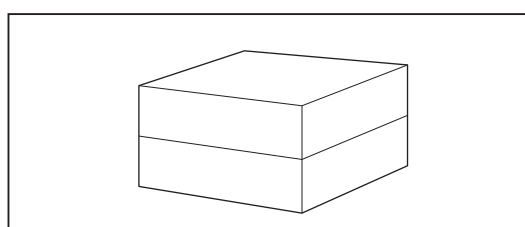

## Dust Cover CM-A69

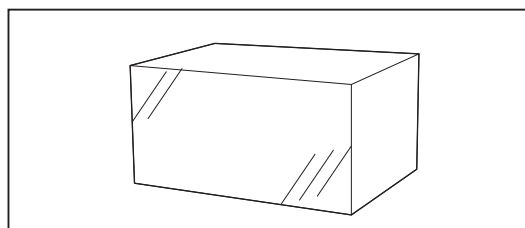

# Optional Accessories

## Software

### **SpectraMagic™ NX CM-S100w**

This software provides various functions (e.g., data processing and file management) and allows the user to operate the CM-3700A using a personal computer.

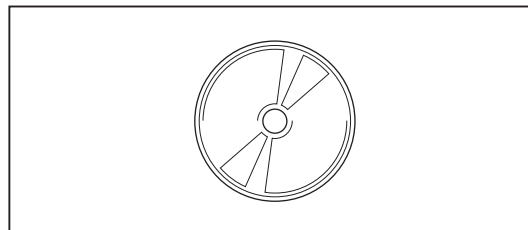

### **Transmittance Specimen Holder CM-A96**

Used to hold the specimen for measurement of transmittance. It can hold specimens up to 22.5 mm (7/8 in.) thick.

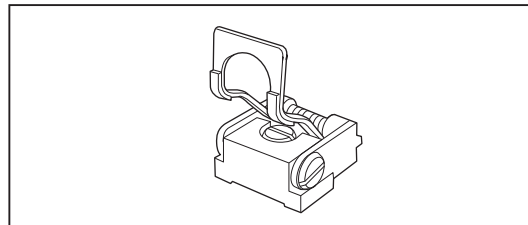

## Plastic Cell

**CM-A130 (optical path length 2mm)**

**CM-A131 (optical path length 10mm)**

**CM-A132 (optical path length 20mm)**

This disposable plastic container is used to hold liquid specimens.

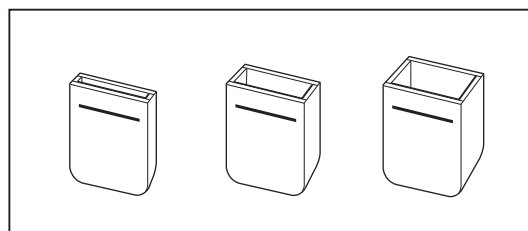

## Cell

**CM-A97 (optical path length 2mm)**

**CM-A98 (optical path length 10mm)**

**CM-A99 (optical path length 20mm)**

This glass container is used to hold liquid specimens.

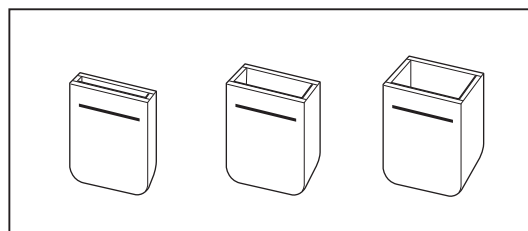

### **Transmittance Zero Calibration Plate CM-A100**

Used when performing zero calibration for transmittance measurements.

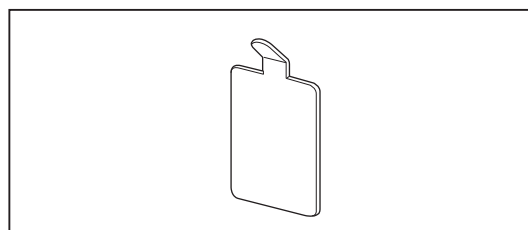

### **USB Cable (5 m) IF-A22**

Used to connect the instrument to a personal computer (PC).

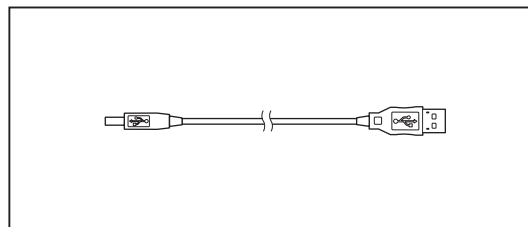

# System Diagram

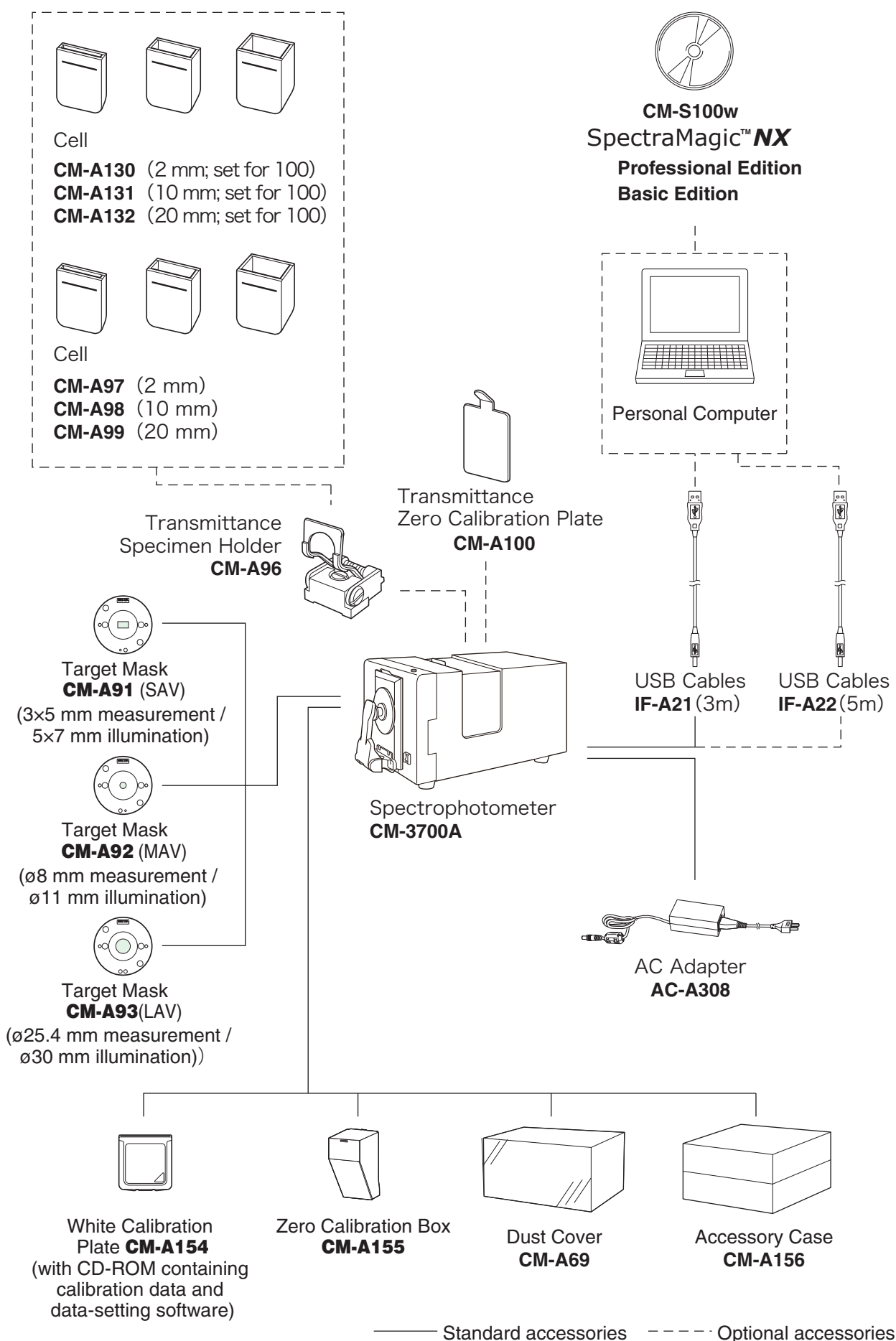

# Names and Functions of Parts

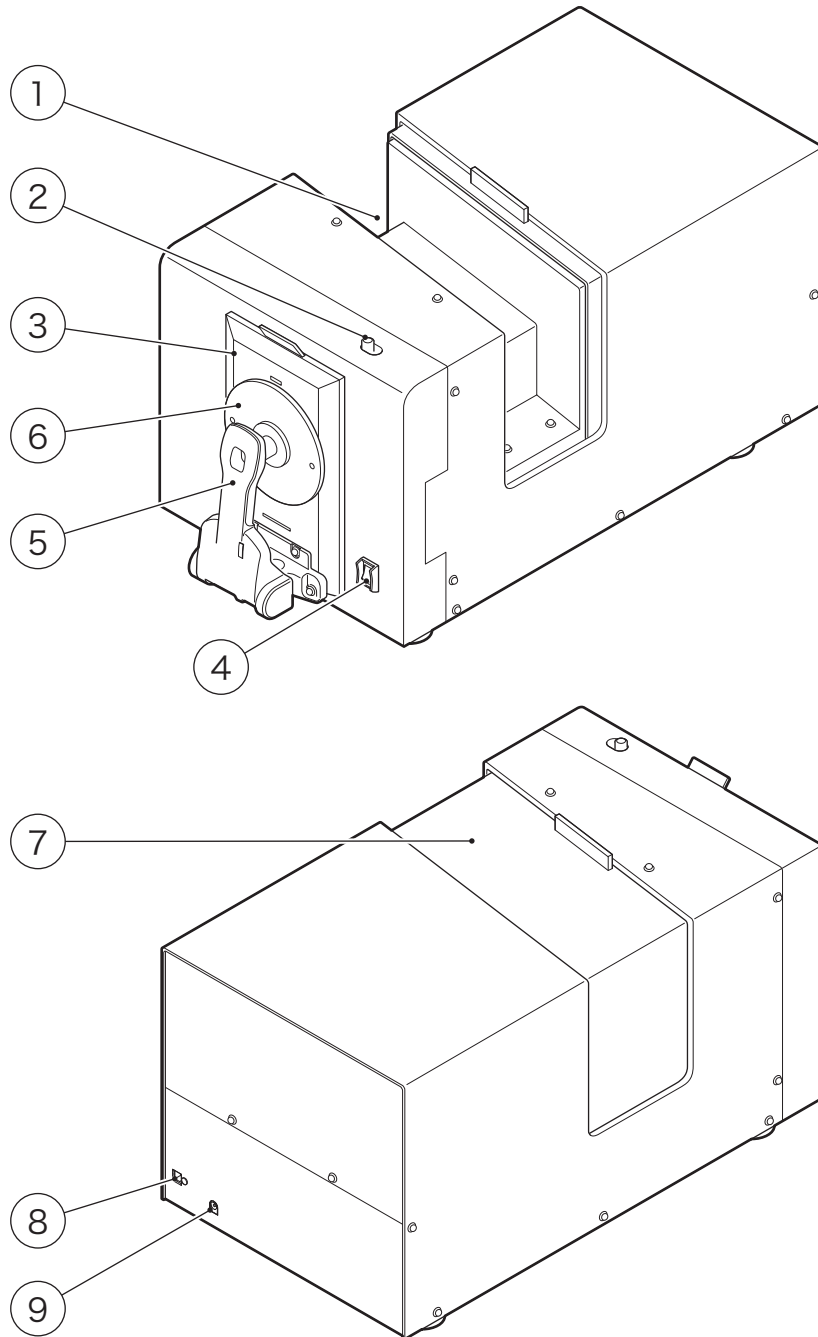

- ① Transmittance chamber ..... Place the specimen in this chamber to perform measurement of transmittance.
- ② Measurement port baseplate lock..... Used to release the lock of the measurement port base plate.
- ③ Measurement port baseplate ..... Can be opened check position of specimen for reflectance measurements.
- ④ Power switch ..... Used to turn power ON and OFF.
- ⑤ Sample holder ..... Used to hold the specimen, white calibration plate or zero calibration box.
- ⑥ Target mask..... Select a suitable target mask (for 5×7mm (SAV), ø11mm (MAV) and ø30mm (LAV) measurements) according to the specimen and attach it to the CM-3700A.
- ⑦ Transmittance specimen chamber cover.... Covers the transmittance specimen chamber when slid closed.
- ⑧ USB connection terminal ..... Used to connect the instrument to a PC with the supplied USB cable (IF-A21 or IF-A22).
- ⑨ AC adapter input socket..... Used to connect the AC adapter supplied with the CM-3700A.

# Measurement Procedure

- ¥ This manual explains how to prepare the CM-3700A and how to set a specimen.
- ¥ The CM-3700A is controlled by a PC to perform measurements.
- ¥ For a description of measuring method using SpectraMagic™ NX (optional), refer to the SpectraMagic™ NX instruction manual.

## ■ Flow of Preparation and Measurement

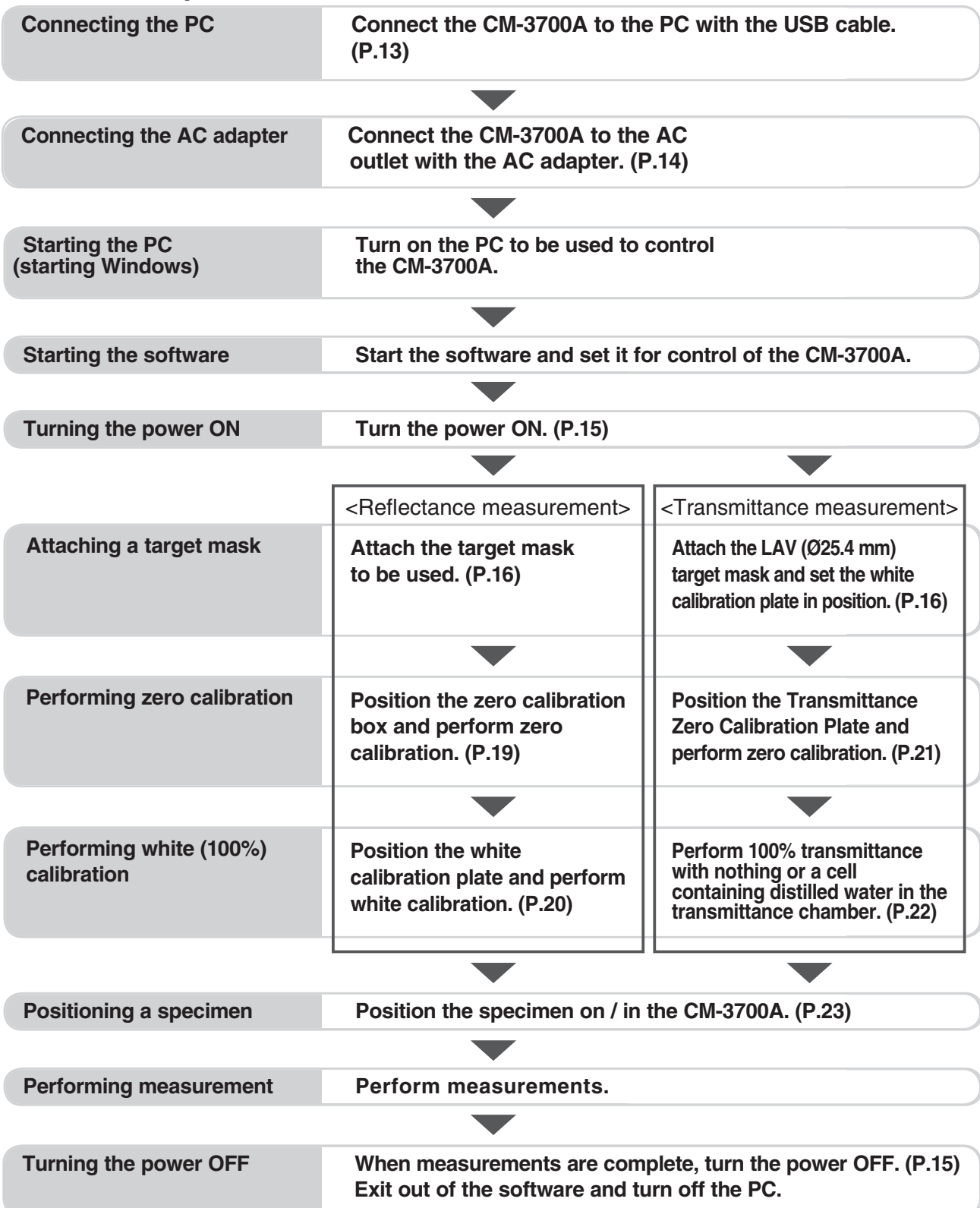

# Connecting a Personal Computer

Connect the instrument to a PC with the supplied USB cable IF-A21 (3 m).

**Memo/**

- To connect the instrument with a PC, it is recommended that you use software that enables connection and operation of the instrument (such as the optional Color Management Software SpectraMagic™ NX).
  - The USB communication port of the instrument conforms to USB 1.1.
- To connect the instrument to a PC, you need to install the USB driver dedicated to the CM-3700A. Install the USB driver supplied with the software that enables connection and operation of the instrument.
  - The instrument is not designed to be powered via the USB cable. You need to connect the AC adapter.
  - Make sure that the USB connector plug is oriented correctly and connected securely.
  - When connecting/disconnecting the USB cable, be sure to hold the connector plug. Do not pull on or forcibly bend the cable. Otherwise, wire breakage may result.
  - Make sure that the cable has sufficient length. Putting tension on the cable may cause connection failure or wire breakage.
  - To connect the USB cable connector, check the shape of the receptacle (connection terminal) and insert the connector fully until it is secured.

## Operating Procedure

In general, a USB cable can be connected/disconnected while the instrument is turned ON; however, you need to turn OFF the instrument in the procedure below. See P.14 for how to connect the AC adapter and P.15 for how to switch the power on and off.

### 1. Turn OFF the instrument (Press the “○” side of the Power switch.).

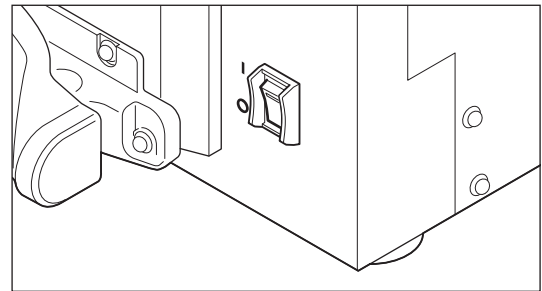

### 2. Connect the B connector of the USB cable to the USB connection terminal (B type) of the instrument.

- Fully insert the connector and ensure secure connection.

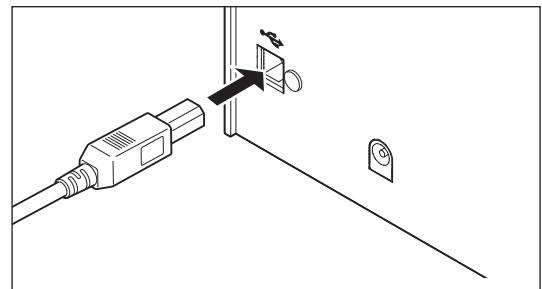

### 3. Connect the A connector of the USB cable to the USB port of the PC.

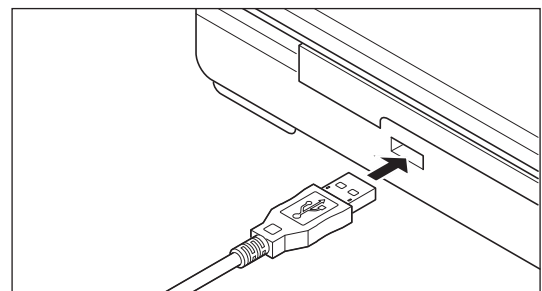

### 4. Connect the AC adapter and turn ON the instrument (Press the “I” side of the Power switch.).

- When you are prompted to install the USB driver, specify the USB driver included with the software or the white calibration data CD and complete the installation.
- When using the optional Color Management Software SpectraMagic™ NX, refer to the SpectraMagic™ NX Installation Guide.
- After installation of the USB driver has finished, switch the instrument off for a few seconds and then switch it back on.

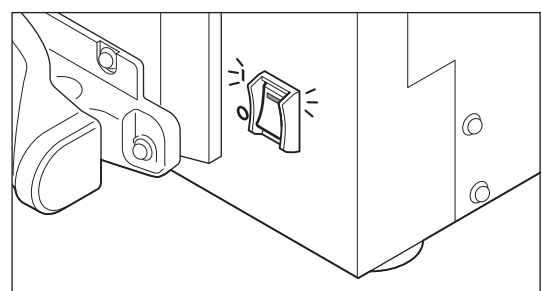

# Connecting the AC Adapter



## WARNING



Always use the AC adapter supplied as a standard accessory or specified replacement AC adapter with the CM- 3700A, and connect it to an AC outlet of the rated voltage and frequency. Failure to do so may damage the CM- 3700A or the AC adapter, causing a fire or electric shock.



If the CM-3700A will not be used for a long time, disconnect the AC adapter from the AC outlet. Accumulated dirt or water on the prongs of the AC adapter's plug may cause a fire and should be removed.



Do not insert or disconnect the AC adapter with wet hands. Doing so may cause electric shock.



Insert the power plug fully and securely. Incomplete inserting may cause fire or electric shock.



Do not disassemble or modify the AC adapter. Doing so may cause a fire or electric shock.



Do not unplug or plug in the AC adapter with the instrument's power switch set to ON. Doing so may cause malfunction.

## Connecting Procedure

**1. Make sure that the power switches of both CM-3700A and host PC are set to OFF ("O").**

**2. Insert the output plug of the AC adapter into the AC adapter input socket on the rear of the CM-3700A.**

**3. Insert the input plug of the AC adapter into an AC wall outlet.**

- The AC Adapter AC-A308 supplied as the standard accessory must be used.
- Before disconnecting the AC adapter, the power switch must be set to OFF ("O").

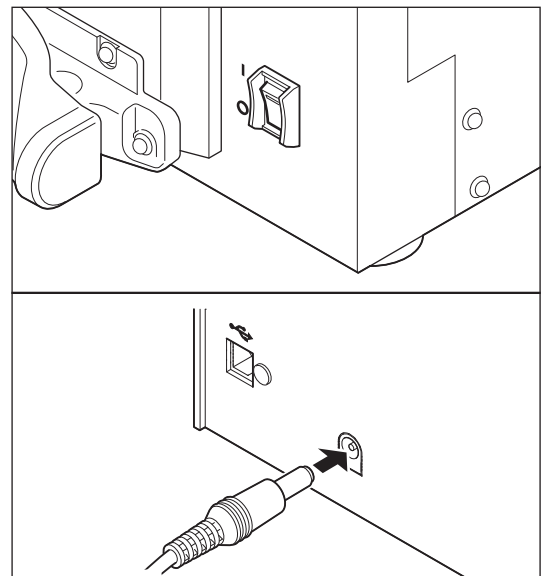



# Turning Power ON and OFF

## **WARNING**

-  The CM-3700A should not be operated if the CM-3700A or the AC adapter is damaged, or smoke or strange odors occur. Doing so may result in a fire. In such situations, turn the power OFF immediately, disconnect the AC adapter from the AC outlet, and contact the nearest Konica Minolta-authorized service facility.

### Procedure

- 1. To turn the power ON and to light the lamp on the power switch, set the power switch to ON (“ I “).**

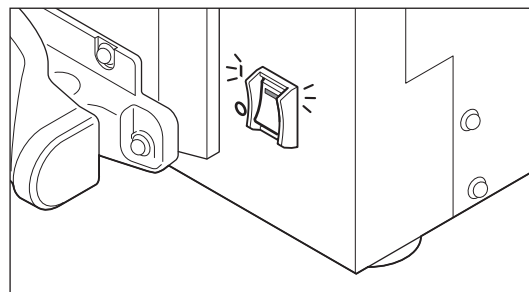

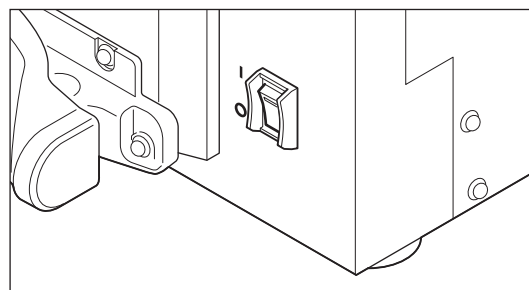

- 2. To turn the power OFF, set the power switch to OFF (“ O “).**



# Attaching a Target Mask

## WARNING

-  Do not place the CM-3700A on an unstable or sloping surface. Doing so may result in its falling or overturning, causing injury. Take care not to drop the CM-3700A when carrying it.
-  Be careful around openings in the CM-3700A. Failure to do so may result in fingers being trapped causing injury.

The CM-3700A allows you to select a target mask from the following three types according to the specimen and your application.

### Target mask

CM-A91 (for LAV 3×5 mm measurements: illumination area: 5×7 mm)

CM-A92 (for MAV ø8 mm measurements: illumination area: ø11 mm)

CM-A93 (for SAV ø25.4 mm measurements: illumination area: ø30 mm)

### Procedure

#### 1. Pull the sample holder toward you and keep it open.

- The sample holder will remain open when opened more than 70 degrees.

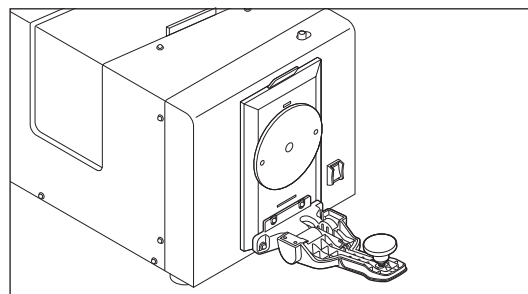

#### 2. Remove the currently attached target mask by pulling it toward you.

**[Memo]** • The target mask is held on by magnets.

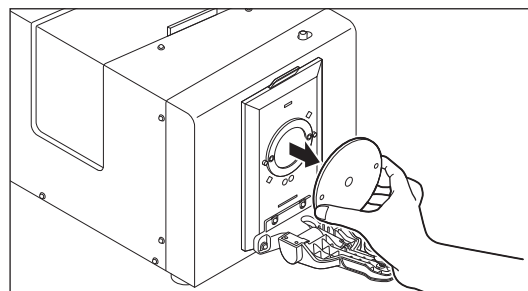

#### 3. Align the target mask positioning holes of the target mask to be attached with the target mask positioning pins of the Spectrophotometer's specimen port baseplate and slide the target mask in against the specimen port baseplate.

**[Memo]** • The target mask should be attached in the direction that makes the white painted surface face inside (toward the CM-3700A side) and position the letters "MADE IN JAPAN" at the top.

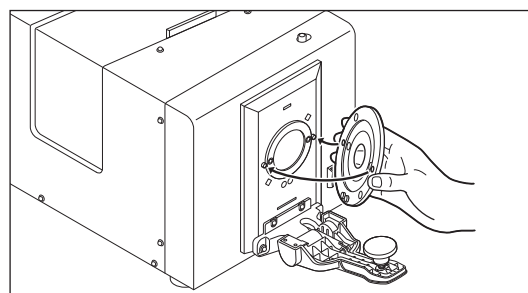

#### 4. Release the sample holder to close it.

### ■ Notes on Use of Target Mask

- Take care not to scratch or make the inner surface (white-coated surface) of the target masks dirty with such as fingerprints.
- The target masks may become discolored if left in areas exposed to light. Therefore, make sure that target masks which are currently not in use are kept inside the accessory case (CM-A156) to prevent exposure to light.
- When not using the CM-3700A, attach one of the target masks or the protective cap to prevent dust entering the integrating sphere.
- Take care not to leave the CM-3700A for a long period of time with a target mask attached. The sample holder may stick to the target mask.

# Calibration of Reflectance and transmittance measurements

## ■ Calibration for Reflectance Measurements

After the Spectrophotometer has been switched on, zero calibration and white calibration must be performed before spectral reflectance measurements are taken. Zero calibration is performed using the Zero Calibration Box (which has a reflectance of 0%) to set the zero reference point for reflectance measurements; white calibration is performed using a white calibration plate (which has a reflectance of approximately 100% and for which spectral reflectance data are provided as white calibration data) to set a high-reflectance reference point for reflectance measurements.

## ■ White calibration data

The white calibration data of the White Calibration Plate are provided under the following six kinds of measurement conditions. When the CM-3700A is purchased, these data are already set within the instrument.

- Measurement area : SAV (3 x 5 mm) / Specular component : SCI
- Measurement area : MAV(ø 8 mm) / Specular component : SCI
- Measurement area : LAV (ø 25.4 mm) / Specular component : SCI
- Measurement area : SAV (3 x 5 mm) / Specular component : SCE
- Measurement area : MAV(ø 8 mm) / Specular component : SCE
- Measurement area : LAV (ø 25.4 mm) / Specular component : SCE

## ■ Calibration for Transmittance Measurements

After the Spectrophotometer has been switched on, 0% calibration and 100% calibration must be performed before spectral transmittance measurements are taken. 0% calibration is performed by blocking the light path with an opaque material (a material which has a transmittance of 0%) to set the 0% reference point for transmittance measurements. 100% calibration is performed using either air (when measuring solid specimens) or distilled water (when measuring liquid specimens) to set a high-transmittance reference point for transmittance measurements; in both cases (air and water) the transmittance is assumed to be 100% for all wavelengths.

- Since using the LAV target mask and setting the measurement area to LAV and the SCI/SCE setting to SCI provides the most stable data for transmittance measurements, it is recommended that transmittance measurements and calibration (both 0% calibration and 100% calibration) for transmittance measurements be performed under these conditions.
- The EEPROM of the Spectrophotometer has space for one set of calibration data for transmittance measurements.

## ■ 100% calibration data

Because it is necessary to set the 100% transmittance data to the CM-3700A for all wavelengths, 100% calibration data are normally set to all wavelengths at shipment.

## ■ Performing calibration

Calibration (both zero calibration and white calibration or both 0% calibration and 100% calibration) is effective only while the Spectrophotometer remains switched on. If it is switched off and then switched on again, both zero calibration and white calibration (or both 0% calibration and 100% calibration) must be performed before measurements are taken.

- The calibration becomes effective only when being performed under six kinds of measurement conditions. Therefore, for example, when performing the measurement of SCI and SCE alternately, performing the measurement by switching the measurement area in a sequential order, or by switching the UV light quantity, if you perform zero calibration and white calibration (0% calibration and 100% of calibration) in advance as to up to six kinds of necessary measurement conditions, you do not have to perform calibration every time the measurement conditions are changed. However, to more accurately perform measurement, it is recommended to perform zero calibration and white calibration (0% calibration and 100% calibration) every time measurement conditions are changed.
- When the calibration has been performed under the seventh kind of measurement conditions, the oldest calibration becomes ineffective and the calibration performed under the seventh kind of measurement conditions becomes effective as the latest. Moreover, when the calibration is re-performed under the same measurement conditions as one calibration that was already performed, not that the oldest calibration becomes ineffective, but the calibration already performed under the same measurement conditions becomes ineffective and the re-performed calibration becomes effective as the latest.

Example) First, zero calibration and white calibration are performed under the following six kinds of measurement conditions in numerical order.

- ① Measurement area : SAV / Specular component : SCI / Target mask : SAV / UV light quantity 99.9
- ② Measurement area : MAV / Specular component : SCI / Target mask : MAV / UV light quantity 99.9
- ③ Measurement area : LAV / Specular component : SCI / Target mask : LAV / UV light quantity 99.9
- ④ Measurement area : SAV / Specular component : SCE / Target mask : SAV / UV light quantity 99.9
- ⑤ Measurement area : MAV / Specular component : SCE / Target mask : MAV / UV light quantity 99.9
- ⑥ Measurement area : LAV / Specular component : SCE / Target mask : LAV / UV light quantity 99.9

In this case, the calibration can be performed under all the six kinds of measurement conditions. Moreover, the calibration can be performed when UV light quantity is set except 99.9. However, in this case, the measured value is calculated and output based on the nearest UV light quantity (in this example 99.9).

Next, if the calibration under the conditions

- ⑦ Measurement area : SAV / Specular component : SCE / Target mask : SAV / UV light quantity 99.9
- is re-performed, not that the oldest calibration under the conditions ① becomes ineffective, but the calibration under the conditions ④, which was performed under the same measurement conditions, becomes ineffective and the calibration under the conditions ⑦ becomes effective as the latest.

Next, if the calibration under the seventh kind of conditions



- ⑧ Measurement area : MAV / Specular component : SCI / Target mask : MAV / UV light quantity 90.0
- is performed, the oldest calibration under the conditions ① becomes ineffective and the calibration under the conditions ⑧ becomes effective as the latest. As a result, effective calibrations can be arranged in the following chronological order.

- ② Measurement area : MAV / Specular component : SCI / Target mask : MAV / UV light quantity 99.9
- ③ Measurement area : LAV / Specular component : SCI / Target mask : LAV / UV light quantity 99.9
- ⑤ Measurement area : MAV / Specular component : SCE / Target mask : MAV / UV light quantity 99.9
- ⑥ Measurement area : LAV / Specular component : SCE / Target mask : LAV / UV light quantity 99.9
- ⑦ Measurement area : SAV / Specular component : SCE / Target mask : SAV / UV light quantity 99.9
- ⑧ Measurement area : MAV / Specular component : SCI / Target mask : MAV / UV light quantity 90.0

- The measured values are affected by UV light quantity to some extent. If you want to perform rigorous measurement, after changing the UV light quantity, zero calibration and white calibration (0% calibration and 100% calibration) should be performed. When performing the fluorescent measurement that does not require rigorous measured values, the measurement should be performed with the UV light quantity of 99.9.
- Due to temperature changes in the surrounding environment and heat generation caused by repeated applications, the indicated values may subtly deviate, but if the calibration is regularly performed, the measurement accuracy will improve.

# Attaching the Zero Calibration Box

## **WARNING**

-  Do not perform measurement with the specimen measuring port directed towards your face. Doing so may cause damage to your eyes .
-  Be careful around openings in the CM-3700A. Failure to do so may result in fingers being trapped causing injury.

The zero calibration box is used to perform zero calibration for measurement of reflectance and to perform haze measurement at measurement of transmittance.

- Make sure that there is nothing in the transmittance chamber.
- Before performing zero calibration, attach the target mask to be used for measurements.
- Before performing zero calibration, set the same measurement area, specular component (SCI/SCE), and UV light quantity as when performing zero calibration using the software. In the fluorescent measurement that does not require rigorous accuracy (that does not perform fluorescent calibration), perform measurement under the condition that the UV cut-off filter does not cover the xenon lamp (UV light quantity is 99.9).

## Procedure

### **1. Pull the sample holder toward you and keep it open.**

- The sample holder will remain open when opened more than 70 degrees.

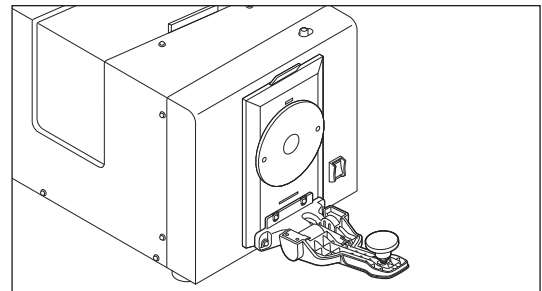

### **2. Fit the projections of the zero calibration box into the grooves on the CM-3700A and then close the sample holder to hold the box in place.**

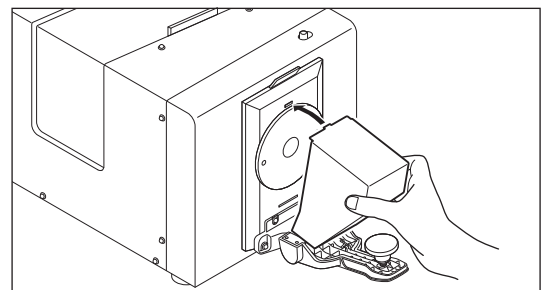



## ■ Notes on Use of Zero Calibration Box

- Take care not to scratch, touch, or make the inside of the zero calibration box dirty with such as fingerprints.
- If the inside of the zero calibration box gets dirty, wipe it with a soft, clean, dry cloth.
- If dirt is difficult to remove, dampen a cloth with commercially available lens cleaning liquid and wipe the zero calibration box. Then wipe off the liquid with a cloth dampened with water, and leave the box to dry.
- Should the inside of the zero calibration box get so dirty that it cannot be cleaned, replace the box with a new one.

# Attaching the White Calibration Plate

## CAUTION

-  Do not perform measurement with the specimen measuring port directed towards your face. Doing so may cause damage to your eyes .
-  Be careful around openings in the CM-3700A. Failure to do so may result in fingers being trapped causing injury.

The white calibration plate is used to perform white calibration for measurement of reflectance and to cover the reflectance measuring port when performing transmittance measurements (zero calibration, 100% calibration, measurement).

- Make sure that there is nothing in the transmittance chamber.
- Before performing white calibration, attach the target mask to be used for measurements.
- Before performing zero calibration, set the same measurement area, specular component (SCI/SCE), and UV light quantity as when performing zero calibration using the software.

In the fluorescent measurement that does not require rigorous accuracy (that does not perform fluorescent calibration), perform measurement under the condition that the UV cut-off filter does not cover the xenon lamp (UV light quantity is 99.9).

## Procedure

### 1. Pull the sample holder toward you and keep it open.

- The sample holder will remain open when opened more than 70 degrees.

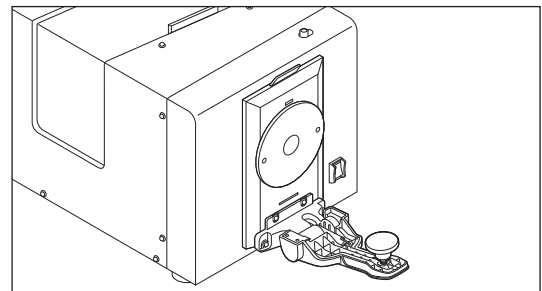

### 2. Position the white calibration plate so that it is held in place by the sample holder by fitting the sample holder pad into the concave (rear) side of the white calibration plate as shown at right.

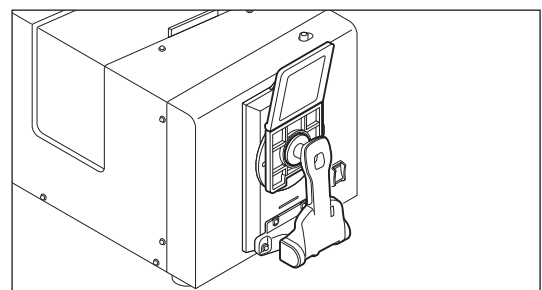

## ■ Notes on Use of White Calibration Plate

**Memo** • When performing white calibration, the white calibration data for the white calibration plate being used is required. The white calibration data for the white calibration plate included with the instrument is stored in the instrument's memory at the time of shipment.

- The white calibration plate may become discolored if left exposed to light. Therefore, when not in use, make sure that the lid is closed to prevent exposure to light.
- Take care not to scratch, touch, or make the white calibration plate surface dirty with such as fingerprints.
- If the white calibration plate gets dirty, wipe it with a soft, clean, dry cloth.
- If dirt is difficult to remove, dampen a cloth with commercially available lens cleaning liquid and wipe the white calibration plate. Then wipe off the liquid with a cloth dampened with water, and leave the plate to dry. Should the white calibration plate get so dirty that it cannot be cleaned, replace the plate with a new one. If the White Calibration Plate is changed, reset the white calibration data to the new plate's.

## ■ Updating White Calibration Data

- You may use the "Data Setting Tool software" stored on the CD-ROM accompanying White Calibration Plate CM-A139 or the optional Color Data Software SpectraMagic™ NX to set the white calibration data.

# Attaching the Transmittance Zero Calibration Plate (Optional Accessory)

The Transmittance Zero Calibration Plate is used for performing zero calibration for transmittance measurements.

- Before starting transmittance calibration and measurements, attach the LAV ( $\varnothing 25.4$  mm) target mask and position the white calibration plate at the reflectance measuring port.
- Before starting transmittance calibration and measurements, set the measurement area to LAV and the specular component to SCI using the software.
- Before starting transmittance calibration and measurements, set the same UV light quantity as when performing measurements using the software. In the fluorescent measurement that does not require rigorous accuracy (that does not perform fluorescent calibration), perform measurement under the condition that the UV cut-off filter does not cover the xenon lamp (UV light quantity is 99.9).

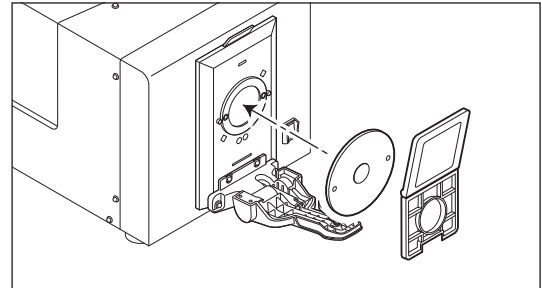

## Procedure

**1. Open the cover of the transmittance chamber.**

**2. Position the Transmittance Zero Calibration Plate in the transmittance chamber so that it completely blocks the illumination window.**

**Memo** • When using the optional Transmittance Specimen Holder, position the Transmittance Zero Calibration Plate in the holder. For information on installing the optional Transmittance Specimen Holder, refer to the instructions included with it.

**3. Close the cover of the transmittance chamber.**

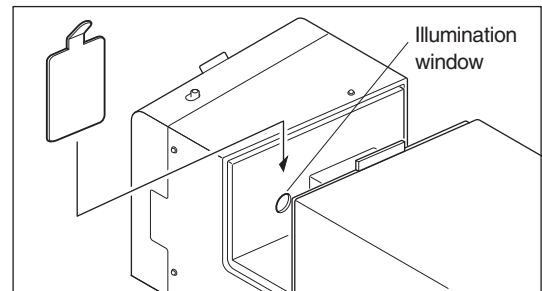

## ■ Notes on Use of Transmittance Zero Calibration Plate

- Take care not to scratch, touch, or make the surface of the transmittance zero calibration plate dirty with such as fingerprints.
- If the transmittance zero calibration plate gets dirty, wipe it with a soft, clean, dry cloth.
- If dirt is difficult to remove, dampen a cloth with commercially available lens cleaning liquid and wipe the zero calibration plate. Then wipe off the liquid with a cloth dampened with water, and leave the plate to dry.
- Should the transmittance zero calibration plate get so dirty that it cannot be cleaned, replace the plate with a new one.

# Performing 100% calibration

Two methods for performing 100% calibration for transmittance measurements are possible:

- 100% calibration to air:  
When the specimen to be measured is in sheet or solid form, 100% calibration should be performed with the transmittance chamber empty.
- 100% calibration to water:  
When the specimen to be measured is in liquid form and will be measured using a cell (optional accessory), 100% calibration should be performed using distilled (or pure) water in the same size and type cell as will be used for measurements.

- Before starting transmittance calibration and measurements, attach the LAV ( $\phi 25.4$  mm) target mask and position the white calibration plate at the reflectance measuring port.
- Before starting transmittance calibration and measurements, set the measurement area to LAV and the specular component to SCI using the software.
- Before starting transmittance calibration and measurements, set the same UV light quantity as when performing measurements using the software.

In the fluorescent measurement that does not require rigorous accuracy (that does not perform fluorescent calibration), perform measurement under the condition that the UV cut-off filter does not cover the xenon lamp (UV light quantity is 99.9).

After setting up the instrument as described below for your selected 100% calibration method, perform 100% calibration from your software.

## ■ Setting up instrument for 100% calibration to air

### Procedure

1. Open the cover of the transmittance chamber.
2. Make sure that there is nothing (specimen, cell, Transmittance Zero Calibration Plate, etc.) between the illumination window and the receiving window in the transmittance chamber.

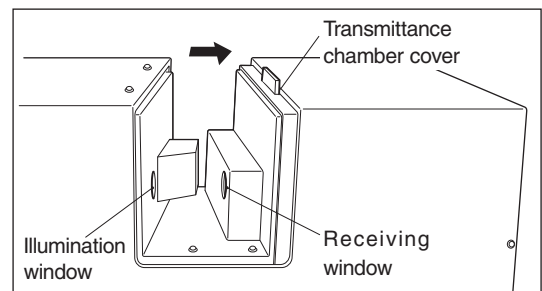
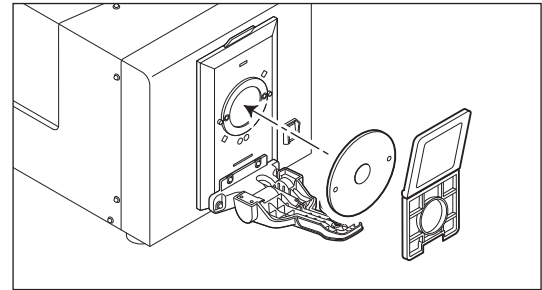

**Memo** • It is no problem that the optional Transmittance Specimen Holder CM-A96 is installed in the transmittance chamber.

3. Close the cover of the transmittance chamber.

## ■ Setting up instrument for 100% calibration to water

### Procedure

1. Open the cover of the transmittance chamber.
2. Fill the cell with distilled (or pure) water to approximately 2/3 (when using any of the cells available as optional accessories) and position the cell in the optional Transmittance Specimen Holder installed in front of the illumination window inside the transmittance chamber.

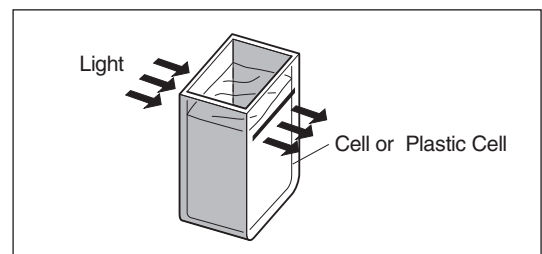

- Although the Transmittance Specimen Holder can be installed in front of either the illumination or receiving window, it is recommended that it is installed in front of the illumination window. In this position, the illumination / observation geometry is diffuse illumination/ $0^\circ$  viewing angle.
- The cell used for calibration should be the same type and have the same optical path length as the cell which will be used for measurements.
- The cell should be positioned in the optional Transmittance Specimen Holder so that the clear sides of the cell are facing the illumination and receiving windows.

3. Close the cover of the transmittance chamber.



# Setting a Specimen



## WARNING



Do not use the CM-3700A in places where flammable or combustible gases (gasoline fumes, etc.) are present. Doing so may cause a fire.



Do not disassemble or modify the CM-3700A. Doing so may cause a fire or electric shock.



The CM-3700A should not be operated if it is damaged, or smoke or strange odors occur. Doing so may result in a fire.

In such situations, turn the power OFF immediately, disconnect the AC adapter from the AC outlet, and contact the nearest Konica Minolta-authorized service facility.



## CAUTION



Do not perform measurement with the specimen measuring port directed towards your face. Doing so may cause damage to your eyes.



Be careful around openings in the CM-3700A. Failure to do so may result in fingers being trapped causing injury.

## ■ Reflectance measurement

- Make sure that there is nothing in the transmittance chamber.
- Before starting reflectance measurements, attach the target mask to be used for measurements.
- Before starting reflectance measurements, set the measurement area, specular component, and UV light quantity using the software.

### Procedure

#### 1. Pull the sample holder toward you and keep it open.

- The sample holder will remain open when it is opened more than 70 degrees.

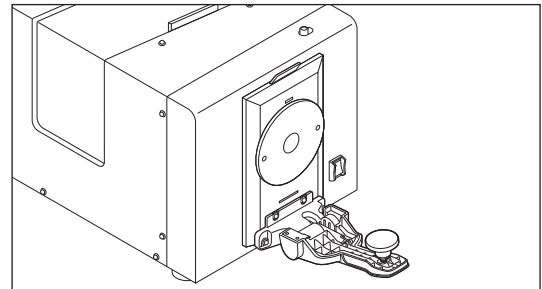

#### 2. Secure the specimen with the sample holder.

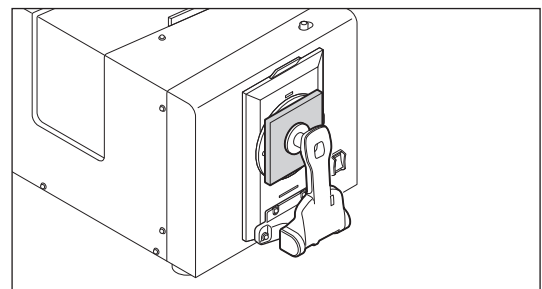

#### 3. Slide the measurement port baseplate lock in the direction of the arrow, open the measurement port baseplate, and check the position of the specimen.

- Hold the measurement port baseplate when sliding the measurement port baseplate lock to keep it from falling open.
- Do not apply strong pressure to the measurement port baseplate when the measurement port baseplate is open.
- The measurement cannot be performed when the measurement port baseplate is open.

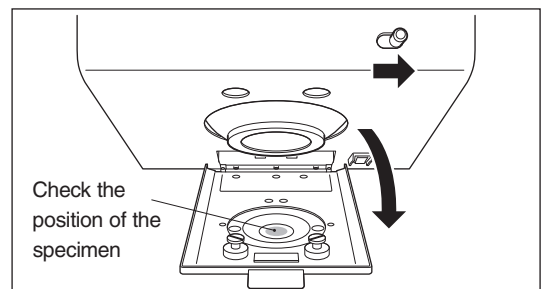

## When widely opening the measurement port baseplate

- If you remove the stopper below the measurement port baseplate, the measurement port baseplate can be widely opened.
- Remove the two stopper attaching screws by turning them counterclockwise using a Phillips-head screwdriver.
- Keep the removed screws and stopper in a safe place.
- When widely opening the measurement port baseplate, install the CM -3700A at the edge of desk so that the sample holder does not touch the desk below.

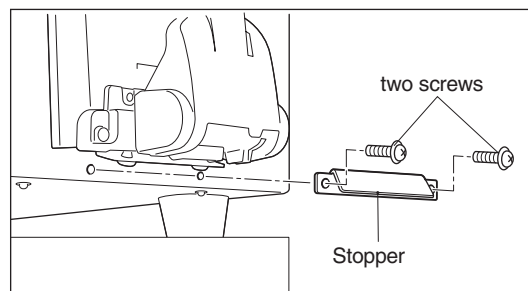

## 4. Repeat the procedure 2 and 3, and after deciding the position of the specimen so that the part that you want to measure is located at the measurement point, close the measurement port baseplate.

- When shifting the position of the specimen, in order to protect the surface of the specimen, you should pull the sample holder toward the front and keep it open.
- When closing the measurement port baseplate, be sure that the measurement port baseplate lock is at the open position (slid in the direction of the arrow). If the lock is in the closed position, the measurement port baseplate cannot be closed.
- Do not open the measurement port baseplate and the transmittance specimen chamber cover while performing measurement. Doing so may result in inaccurate measurement.

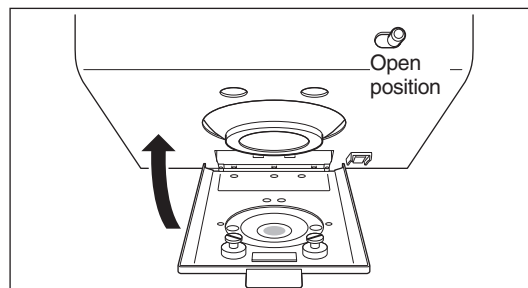

## ■ The sample holder for measuring the reflectance

To measure the reflectance of a film - or plate-like specimen, the specimen needs to be secured with the sample holder. If the specimen cannot be secured in this way, remove the sample holder and hold the specimen against the measurement aperture.

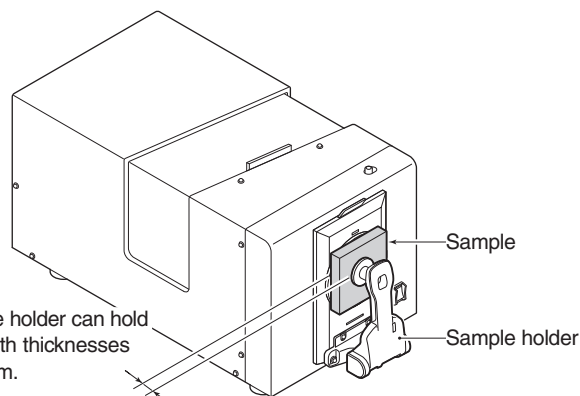

## Removing Sample Holder

### Procedure

## 1. To remove the specimen holder when taking reflectance measurements of large specimens, use a crosspoint screwdriver to turn the four screws of the specimen holder counterclockwise, remove the screws, and then remove the specimen holder.

- Keep the screws and sample holder in a safe place.

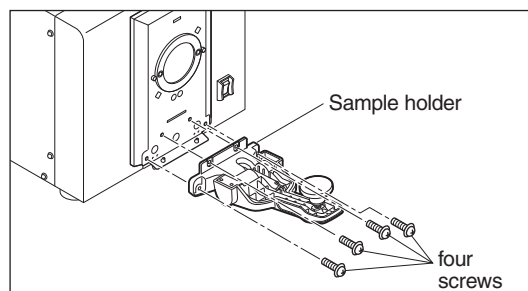

## ■ About opacity measurements

When using the optional Color Management Software SpectraMagic™ NX, pairs of white-backed and black-backed measurements can be taken and opacity can be calculated.

## ■ Transmittance measurements

- Before starting transmittance calibration and measurements, attach the LAV ( $\varnothing 25.4$  mm) target mask and position the white calibration plate at the reflectance measuring port.
- Before starting transmittance calibration and measurements, set the measurement area to LAV and the specular component to SCI using the software.
- Before starting transmittance calibration and measurements, set the UV light quantity using the software.

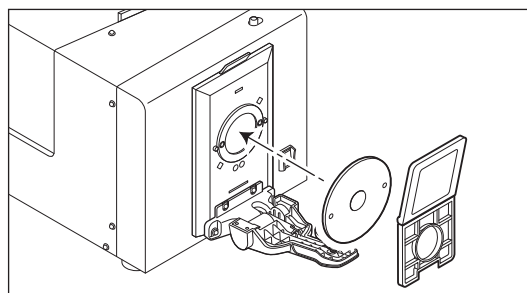

### Procedure

#### 1. Open the cover of the transmittance chamber.

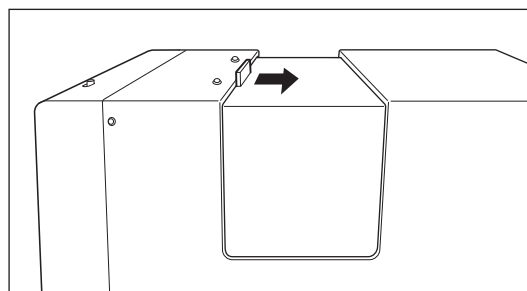

#### 2. Place the specimen against the illumination window tightly. (When measuring a liquid specimen, the specimen container must be placed against the illumination window.)

- The specimen must be placed so that the area to be measured entirely covers the entire illumination window.

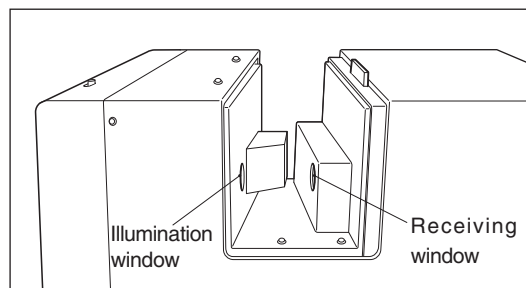

**Memo** • Although the specimen can be placed in front of either the illumination or receiving window, it is recommended that it is placed in front of the illumination window. In this position, the illumination/observation geometry is diffuse illumination/ $0^\circ$  viewing angle. In the position in front of the receiving window, the illumination/observation geometry is approximately  $0^\circ : 0^\circ$ . It does not strictly satisfy the definition of such as CIE No.15. However, this presents no problem if the values are used as relative values.

- It is recommended that the optional Transmittance Specimen Holder CM-A96 be used to hold the specimen in place.
- In the case of a liquid specimen, use of an optional cell (CM-A97 to 99, A130 to 132) is recommended.

- If you are going to use a container other than the above cells, it must be transparent and constructed in such a way that it can be positioned with opposing surfaces parallel to both illumination and receiving windows.
- Take care not to spill the liquid specimen on the CM-3700A. Should there be any spillage, immediately wipe it with a soft, dry cloth.
- Never measure flammable liquids.
- No measurements must be performed if the specimen or its container is scratched or dirty. If you hold the measuring surface of the specimen with your fingers, it will be marked with fingerprints, so always hold another part of the specimen when setting it in place.
- Air bubbles on the inner surface of the specimen's container will hinder correct measurements, so make sure that all air bubbles are removed before measurement. (Air bubbles sometimes develop even if the container is just left standing still.)
- Correct measurements will be hindered if water drops develop on the specimen or its container due to condensation.
- Liquids containing particles may cause unstable measurements due to precipitation of the particles.

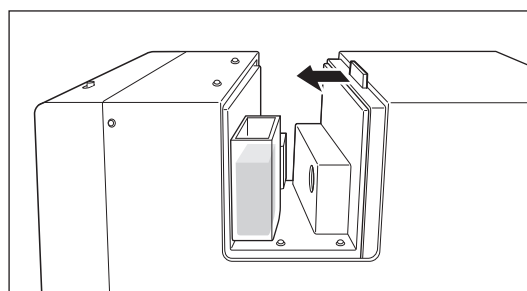

#### 3. Close the cover of the transmittance chamber.

## ■ The transmittance chamber for transmittance measurement

Set the liquid and transmittance specimen to the transmittance chamber. If you cannot set the specimen because it touches the Light Trap in the transmittance chamber, remove the Light Trap before setting the specimen.

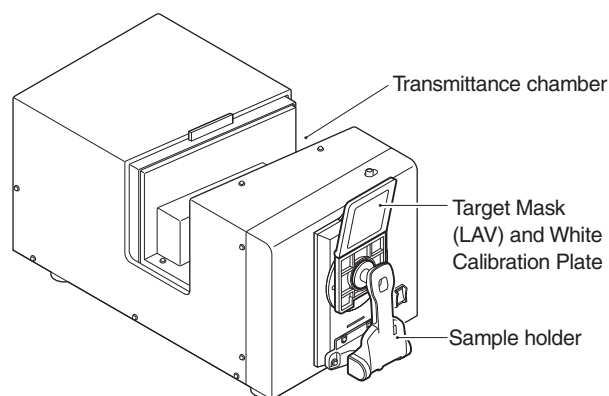

### How to remove / attach the Light Trap

- Before removing or attaching the Light Trap, be sure to set the specular component to SCI using the software.

#### Removing Light Trap

- 1. If the specimen for transmittance measurements cannot be positioned because the light trap is in the way, the light trap can be removed by turning the screw of the light trap counterclockwise, removing the screw, and then removing the light trap.**

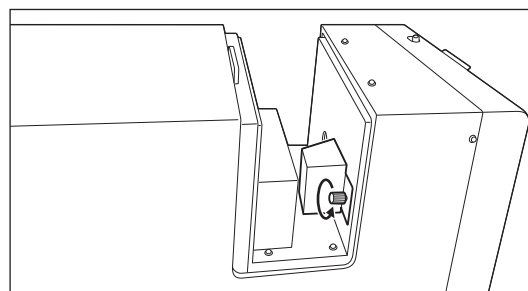

#### Replacing Light Trap

- 1. To replace the light trap, hook the flange of the light trap into the Spectrophotometer as shown, inset the screw, and turn the screw clockwise until snug.**

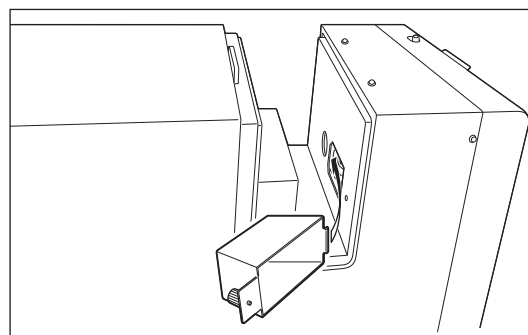

## ■ About haze measurements

When the White Calibration Plate is positioned over the reflectance measuring aperture, the measurement geometry for transmittance measurements becomes  $di:0^\circ$ . When the Zero Calibration Box is positioned over the reflectance measuring aperture, the measurement geometry for transmittance measurements becomes  $de:0^\circ$ .

The illumination/observation system does not strictly satisfy the definition of haze (ASTM D 1003).

However, this presents no problem if the values are used as relative values.

When using the optional Color Management Software SpectraMagic™ NX, these two types of transmittance measurements ( $di:0^\circ$ ,  $de:0^\circ$ ) with and without specimen can be taken and haze can be calculated.

# Cleaning the CM-3700A and Accessories



## WARNING



Do not disassemble or modify the CM-3700A or AC adapter. Doing so may cause a fire or electric shock.



The CM-3700A should not be operated if it is damaged, or if smoke or strange odors occur. Doing so may result in a fire. In such situations, turn the power OFF immediately, disconnect the AC adapter from the AC outlet, and contact the nearest Konica Minolta-authorized service facility.



## CAUTION



When cleaning, disconnect the power plug. Connecting may cause electric shock.



Be careful around openings in the CM-3700A. Failure to do so may result in fingers being trapped causing injury.

## ■ Zero Calibration Box and White Calibration Plate

Wipe gently with a dry soft cloth. If dirt is difficult to remove, dampen a cloth with commercially available lens cleaning liquid and wipe. Then wipe off the liquid with a cloth dampened with water, and leave it to dry.

- When cleaning, take care not to scratch the zero calibration box or white calibration plate.

## ■ Target Mask

Use a blower to remove dirt and dust from the target masks.

- Do not touch the black-coated surface of the target masks with fingers or wipe it with a cloth. If the target masks get so dirty that dirt cannot be removed using a blower, contact the nearest Konica Minolta-authorized service facility.

## ■ Inside Integrating Sphere

### 1. Remove the light trap cover. (See P.26)

- Be sure to set the SCI/SCE setting to SCI before removing the light trap.
- Store the light trap and screw carefully.

### 2. Make sure that there is nothing placed against the illumination window.

### 3. Block the receiving window so that no dust or dirt enters.

### 4. Set the specular component to SCE using the software.

### 5. Open the Measurement port baseplate and remove dust and dirt using a blower.

- Do not touch the white-coated inner surface of the integrating sphere, wipe it with a cloth or place any object against it. If the white-coated surface gets so dirty that dirt cannot be removed using a blower, contact the nearest Konica Minolta-authorized service facility.

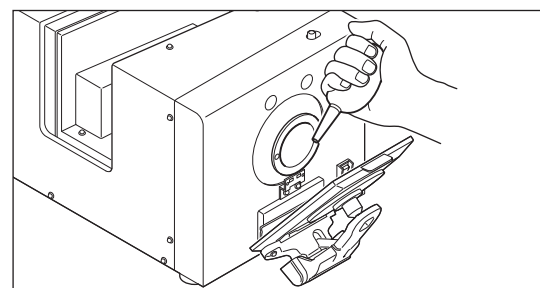
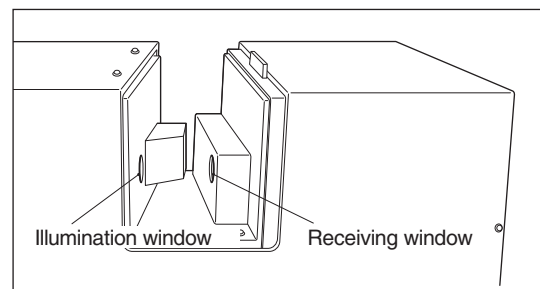

## ■ Receiving Window

### 1. Set the measurement area to SAV using your software.

**[Memo]** • This will cause the lens to move closer to the receiving window, making it easier to clean.

### 2. Use a blower to remove dirt and dust from the receiving window.

- Do not put your fingers into the receiving window or touch any optical lenses.

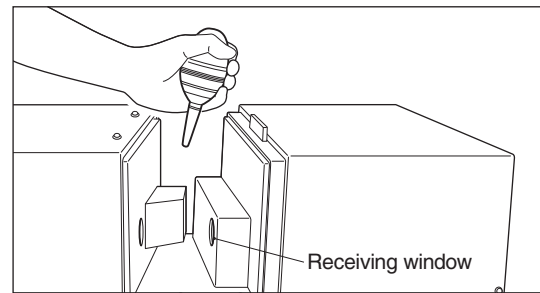

# Error message

The following error messages may appear when you use SpectraMagic® NX CM-S100w, optional color management software, to control the instrument.

If you see an error message, follow the instructions shown in the table below. If a problem persists, contact the nearest Konica Minolta-authorized service facility.

| Error Message  | Problem / possible cause   | Action   | Refer to page |
|--|--|--|---------------|
| Flash Error  | The light amount of the xenon lamp has been lowered to 50% or less. <ul style="list-style-type: none"> <li>• Degradation of the xenon lamp</li> <li>• Contamination of the integrating sphere</li> </ul> | Clean the integrating sphere according to the instructions in "Cleaning the CM-3700A and Accessories" on page 27. If the problem persists, contact the nearest Konica Minolta-authorized service facility. | 27            |
| Flash not ready.   | The illumination unit has not been charged.  | Contact a KONICA MINOLTA-authorized service facility.  | -             |
| Flash Error.   | The xenon lamp failed to emit light. <ul style="list-style-type: none"> <li>• Xenon lamp dead</li> <li>• Illumination circuit failure</li> <li>• Sensor failure"</li> </ul>                              | Retry measurement or perform recalibration. If the message persists, contact the nearest Konica Minolta-authorized service facility.   | -             |
| Incorrect Calibration Procedure.   | The calibration procedure is not correct.<br>The count value is not appropriate for zero (0%) or white (100%) calibration.   | Use the zero calibration box for zero calibration and the white calibration plate for white calibration.   | 19,20         |
| A/D Error.   | A/D conversion failed. <ul style="list-style-type: none"> <li>• A/D converter failure</li> <li>• Circuit failure"</li> </ul>   | Turn the power off and then on again. If the message persists, contact the nearest Konica Minolta-authorized service facility.   | 15            |
| Attached target mask is for smaller measurement area than the selected measurement area. | No target mask is installed or the target mask installed is too small.   | Install a target mask suitable for or larger than the measurement area or diameter.  | 16            |
| Circuit is not operating properly.   | The motor for changing the measurement diameter, adjusting the UV light amount, or switching between SCI and SCE is not working.   | Turn the power off and then on again. If the message persists, contact the nearest Konica Minolta-authorized service facility.   | 15            |
| Not Ready.   | Charging for flashing the xenon lamp is not complete.  | Wait for at least 3 seconds after the last flash. If the message persists, contact the nearest Konica Minolta-authorized service facility.   | -             |

|   |  |  |  |
|---|--|--|--|
| No response from instrument   | Communication with the instrument failed. <ul style="list-style-type: none"> <li>• The power of the instrument is off.</li> <li>• COM port setting is incorrect.</li> <li>• Communication settings are incorrect.</li> </ul> | Turn on the power of the instrument.<br>Check and correct the COM port and communication settings.                         | 15   |
|   | Hardware initialization at power on (of lens, filter and trap positions) is in progress.   | After turning the power on, wait for ten and several seconds until the lens, trap and UV filter positions are initialized. | -  |
| Time for Periodic Calibration. Please contact the closest Service Center.   | It is time to perform periodic calibration.  | Contact a KONICA MINOLTA-authorized service facility and request periodic calibration.                                     | -  |
| Not Calibration data. Set Calibration data. Are you sure?   | The calibration data for while calibration is not found.   | Load the calibration data into the instrument.   | 20   |
| Check UV Settings.  | UV Settings has been set to "100% Full".   | Set the UV Settings to "UV adjustment" .   | Refer to the SpectraMagic™ NX (optional) instruction manual. |
| UV adjustment not possible. Change Standard value or tolerance settings, or use a different Fluorescent Standard.   | Current settings did not allow adjustment of the filter position.  | Change Standard value or tolerance settings, or use a different Fluorescent Standard; then retry "UV adjustment".          | 34   |
| UV adjustment not possible. UV is set to XX and cannot be adjusted further in the required direction. Change Standard value or tolerance settings, or use a different Fluorescent Standard. | Current settings did not allow adjustment of the filter position.  | Change Standard value or tolerance settings, or use a different Fluorescent Standard; then retry "UV adjustment".          | 34   |



# TROUBLESHOOTING GUIDE

If a problem occurs with the Spectrophotometer, please check the following points before requesting service. If the problem continues to occur even after the suggested corrective actions have been taken, contact the nearest Konica Minolta-authorized service facility.

| Condition   | Checkpoint   | Recommended action   | Refer to page |
|---|--|--|---------------|
| Reflectance measurement results seem strange.   | Was specimen positioned correctly?   | Open measurement port baseplate and check measurement point.   | 23            |
|   | Are the white calibration data correct?  | Set the correct white calibration data.  | 20            |
|   | Was white calibration performed correctly?   | Attach White Calibration Plate correctly and perform white calibration correctly.  | 20            |
|   | Was zero calibration performed correctly?  | Attach Zero Calibration Plate correctly and perform zero calibration correctly.  | 19            |
|   | Is there any obstacle in the transmittance chamber?                                  | Make sure that there is nothing in the transmittance chamber.  | 23            |
|   | Was measurement mode set to reflectance?   | By referring to the operation manual of the software, perform the operation correctly.   | —             |
| Transmittance measurement results seem strange.   | Was specimen positioned correctly?   | Position specimen correctly.   | 23            |
|   | Was 100% calibration performed correctly?  | Attach White Calibration Plate correctly and perform 100% calibration correctly using the appropriate calibration standard (air or distilled water). | 22            |
|   | Was zero calibration performed correctly?  | Attach White Calibration Plate correctly, block all light from reaching the receptor window, and perform zero calibration correctly.                 | 21            |
|   | Was measurement mode set to transmittance?   | By referring to the operation manual of the software, perform the operation correctly.   | —             |
| Data input/output between the Spectrophotometer and a computer cannot be performed.<br>Commands cannot be input to the Spectrophotometer from a computer. | Is the USB cable connected correctly to both the Spectrophotometer and the computer? | Connect the USB cable correctly between the Spectrophotometer and the computer.  | 13            |
|   | Is the software operating correctly?   | By referring to the operation manual of the software, perform the operation correctly.   | —             |
|   |  | Set POWER switch of Spectrophotometer to OFF and then set it back to ON.   | 15            |





# Explanations

# Illumination/Observation System

## ■ Measuring Reflected Colors

The flow of measurement is shown below.

The geometry of the CM-3700A conforms to CIE No.15, ISO 7724/1, ASTM E 1164, DIN 5033 Teil 7, and JIS Z 8722 condition c (diffused illumination/perpendicular viewing system) standards, and offers both di:8° (SCI: specular component included ; Total reflectance) and de:8° (SCE: specular component excluded ; Diffuse reflectance) measurements. (SCI/SCE switchable)

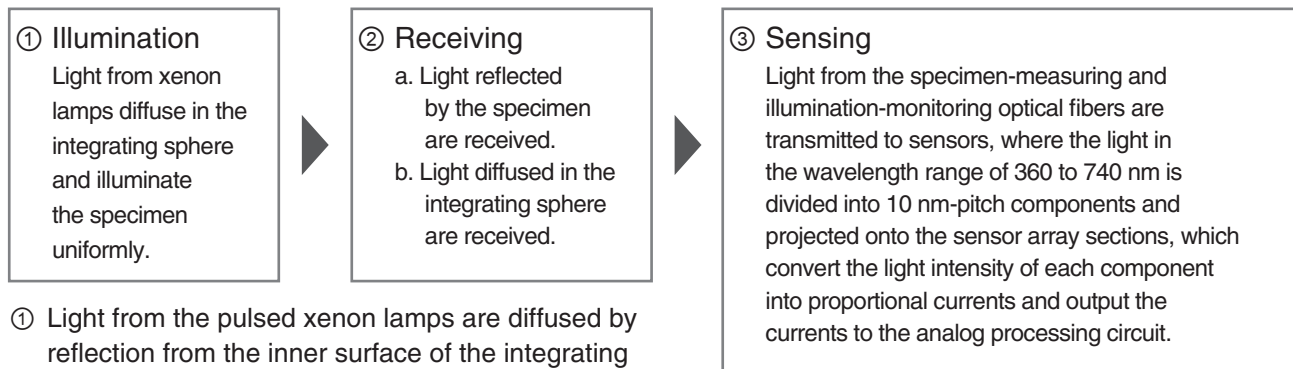

- ① Light from the pulsed xenon lamps are diffused by reflection from the inner surface of the integrating sphere, and finally illuminate the specimen uniformly.
- ② a. The light reflected by the specimen surface at an angle of 8° to the normal to the surface is received by the specimen-measuring optical system and guided to the sensor.  
b. The diffused light in the integrating chamber is received by the illumination-monitoring optical fiber and guided to the sensor.
- ③ The light from the specimen-measuring optical fiber and from the illumination-monitoring optical fiber is divided into each wavelength component and projected onto the sensor array sections, which convert the light into proportional currents and output the currents to the analog processing circuit.

**Memo** • By using the outputs from the specimen-measuring sensor and the illumination-monitoring sensor for calculations, compensation for slight differences in the spectral characteristics and intensity of the illumination light is performed (double-beam system).

## ■ Measuring Transmitted Colors

The flow of measurement is shown below.

The geometry conforms to CIE No. 15, ASTM E 1164, DIN 5033 Teil 7, and JIS Z 8722 condition g, and offers di:0° (SCI: Total transmittance) and de:0° (SCE: Diffuse transmittance) measurements.

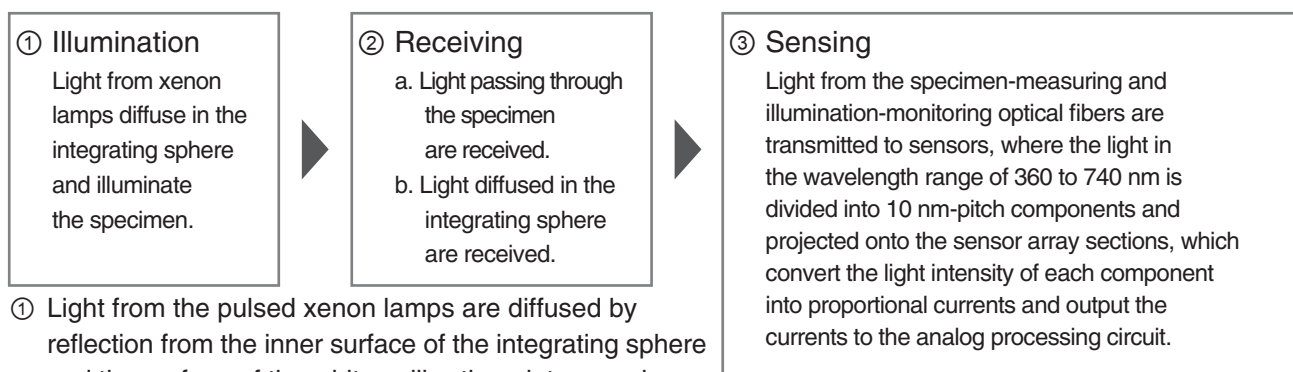

- ① Light from the pulsed xenon lamps are diffused by reflection from the inner surface of the integrating sphere and the surface of the white calibration plate covering the reflectance measurement aperture, and finally illuminate the specimen in the transmittance chamber.
- ② a. The light transmitted by the specimen is received by the specimen-measuring optical system and guided to the sensor.  
b. The diffused light in the integrating chamber is received by the illumination-monitoring optical fiber and guided to the sensor.
- ③ The light from the specimen-measuring optical fiber and from the illumination-monitoring optical fiber is divided into each wavelength component and projected onto the sensor array section, which convert the light into proportional currents and output the currents to the analog processing circuit.

**Memo** • By using the outputs from the specimen-measuring sensor and the illumination-monitoring sensor for calculations, compensation for slight differences in the spectral characteristics and intensity of the illumination light is performed (double-beam system).

# Illumination and Measurement Areas

The CM-3700A allows you to select a target mask from three types: LAV (for  $\varnothing 25.4\text{mm}$  measurements), MAV (for  $\varnothing 8\text{mm}$  measurements) and SAV (for  $3\times 5\text{mm}$  measurements), according to the specimen and your application. Select and attach a suitable target mask (illumination area) for each measurement area.

## ■ Target Mask

Each target mask is equipped with pins at the bottom of the target mask plate; the number and position of these pins indicate to the Spectrophotometer which target mask is attached (and thus which illumination area is being used). However, changing the target mask does not automatically change the measurement area of the Spectrophotometer. Therefore, when changing the target mask, follow the direction of the color conditioning software CM-S100w.

The target mask for SAV measurements is essentially the same as the one for MAV measurements, but with a 0.3 mm-thick diffusion plate attached to increase the illumination area and reduce the edge-loss error which occurs with semitransparent specimens.

The target mask surface which faces into the integrating sphere has a high-reflectance white coating. Since the reflectance of this coating affects measurements, be careful to protect the white surface from scratches and never touch the white surface.

## ■ Measurement Area

When the measurement area is switched from one to another, the condensing lens of the receiving optical system is moved by the motor according to the commands from the software running on a personal computer.

# System Configuration

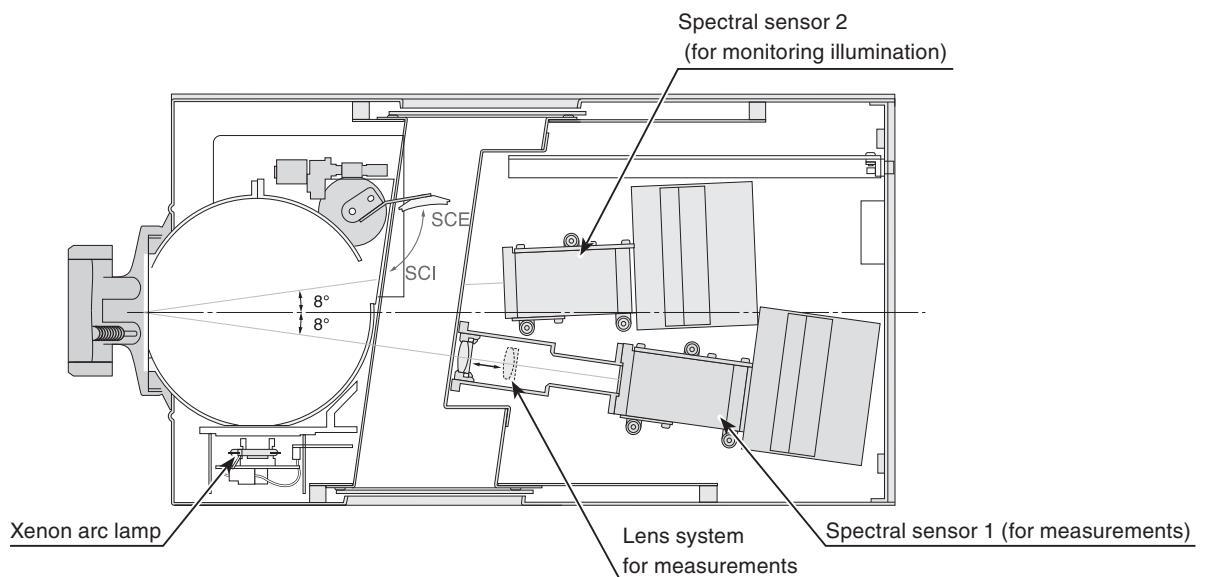

# Fluorescent Measurement

The Spectrophotometer is equipped with a UV cutoff filter positioned in front of the pulsed xenon arc lamp. The position of this filter is controlled by a motor and allows the amount of UV included in the illumination to be controlled. When the pulsed xenon arc lamp is completely blocked by the UV cutoff filter, all light at wavelengths below 390 nm is eliminated from the illumination. The position of the filter can also be adjusted to provide illumination which closely matches CIE illuminant D<sub>65</sub>.

## ■ UV Adjustment

The position of the filter (and thus the amount of UV included in the illumination) can be adjusted in 1000 steps, from 0.0 to 99.9% by software.

For the highest possible accuracy when measuring fluorescent specimens, fluorescent calibration using a standard specimen for which standard values should be performed by measuring the standard specimen repeatedly and the position of the UV filter adjusted so that the measured values closely match the standard values. In addition, since the xenon lamp will age and the light output by the lamp will change over time, it is recommended that fluorescent calibration be performed periodically if fluorescent specimens will be measured.

## ■ WHEN FLUORESCENT CALIBRATION IS PERFORMED

When SpectraMagic™NX is used, the following four fluorescent calibration methods are available to enable accurate measurement of fluorescent reflectance.

### 1. Tint mode

Correction coefficients for fluorescent measurement are obtained so that the measured CIE Tint value for the fluorescent standard plate is within the specified range (Tint value for the fluorescent standard plate calibrated with a D<sub>65</sub> light source is entered).

### 2. Whiteness (WI) mode

Correction coefficients for fluorescent measurement are obtained so that the measured CIE Tint and WI values for the fluorescent standard plate are both within the specified range (Tint and WI values for the fluorescent standard plate calibrated with a D<sub>65</sub> light source are entered).

## ■ WHEN FLUORESCENT CALIBRATION IS NOT PERFORMED

If extremely high accuracy is not required and fluorescent calibration will not be performed, it is recommended that fluorescent specimens be measured with the UV filter completely removed from in front of the xenon lamp, allowing 99.9% of UV to be included in the illumination.

# Dimensions

(mm)

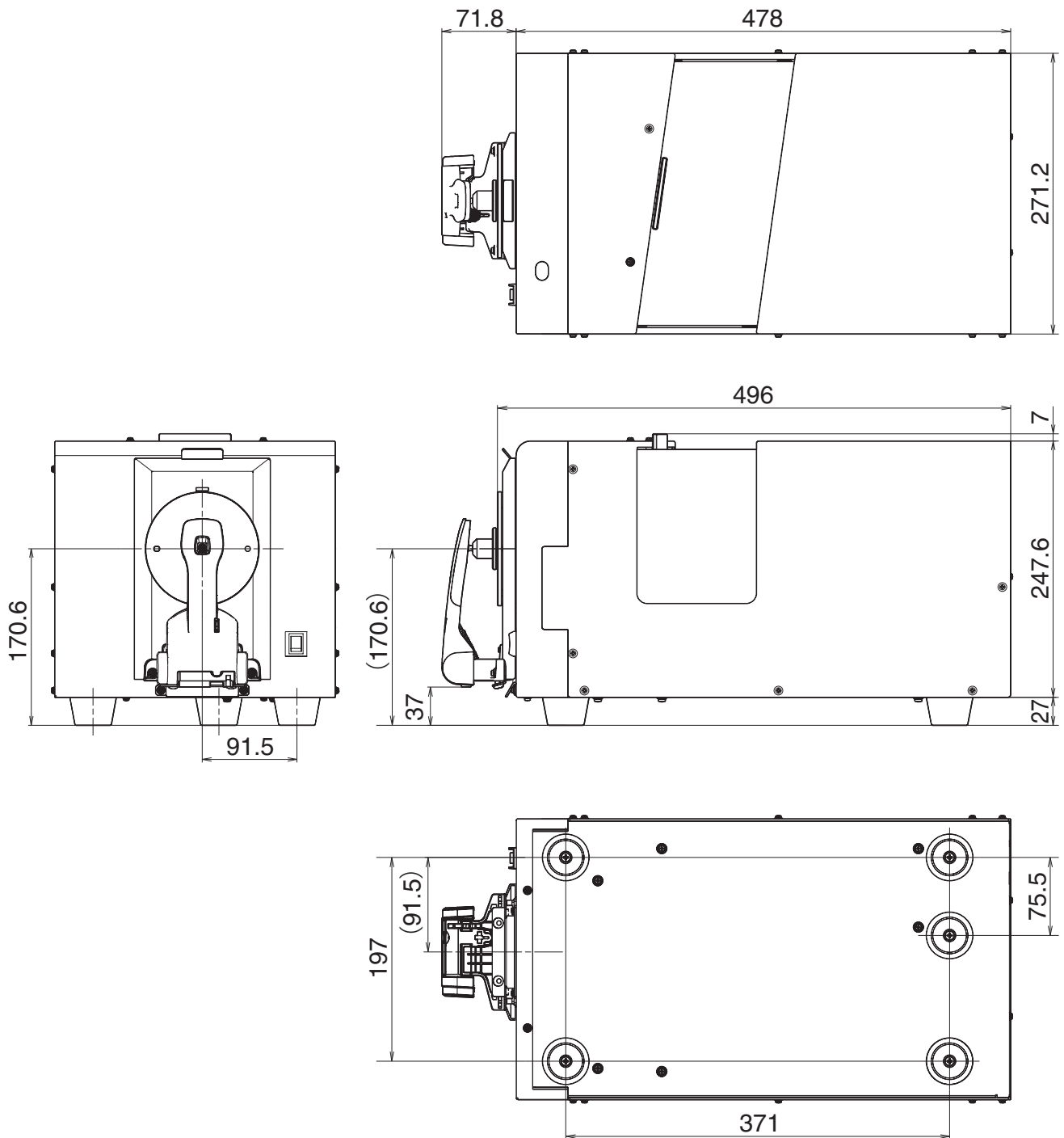

# Specifications

|   |   |   |
|---|---|---|
| Illumination/<br>viewing system               | Reflectance   | di:8°, de:8° (diffuse illumination/8° viewing angle)  |
|   |   | SCI (specular component included)/SCE (specular component excluded) switchable  |
|   |   | Conforms to CIE No.15, ISO 7724/1, ASTM E 1164, DIN 5033 Teil 7 and JIS Z 8722 condition c standard.  |
|   | Transmittance   | di:0°, de:0° (diffuse illumination/0° viewing angle)  |
|   |   | Conforms to CIE No.15, ASTM E 1164, DIN 5033 Teil 7 and JIS Z 8722 condition g standard.  |
| Detector                                      | Silicon photodiode array with flat holographic grating  |   |
| Wavelength range                              | 360 to 740 nm   |   |
| Wavelength pitch                              | 10 nm   |   |
| Half bandwidth                                | Approx. 14 nm average   |   |
| Measuring range                               | 0 to 200%; Resolution: 0.001%   |   |
| Light source                                  | Pulsed xenon arc lamp   |   |
| Minimum measurement interval                  | 3 seconds   |   |
| Measurement/<br>illumination area             | Reflectance   | Changeable between SAV, MAV, and LAV<br>SAV : 3x5 mm measurement / 5x7 mm illumination<br>MAV : ø8 mm measurement / ø11 mm illumination<br>LAV : ø25.4 mm measurement / ø28 mm illumination |
|   |   | Transmittance   |
| Repeatability                                 | 1. When white calibration plate is measured 30 times at 10-sec. intervals after white calibration has been performed:<br>Spectral reflectance: Standard deviation within 0.05%<br>Chromaticity: Standard deviation within $\Delta E^*_{ab}$ 0.005   |   |
|   | 2. When black tile (BCRA Series II; reflectance: 1%) is measured 30 times at 10-second intervals after white calibration has been performed:<br>Spectral reflectance: 380 to 740 nm: Standard deviation within 0.02%<br>360 and 370 nm: Standard deviation within 0.04%<br>Chromaticity: Standard deviation within $\Delta E^*_{ab}$ 0.05 |   |
| Inter-instrument agreement                    | Mean $\Delta E^*_{ab}$ 0.08 (typical) Average for 12 BCRA Series II color tiles.<br>Max $\Delta E^*_{ab}$ 0.3 (corresponds to approx. $\Delta E^*_{CMC}$ 0.2) for any of 12 BCRA Series II color tiles compared to values measured with Konica Minolta master body.   |   |
| UV adjustment                                 | Computer controlled: continuously variable  |   |
| Transmittance chamber                         | Maximum sample thickness: Approx. 50 mm<br>Maximum sample length: Unlimited (no sides when transmittance chamber cover is open)<br>Sample holder (optional) for holding sheet samples or containers of liquid samples can be installed/removed  |   |
| Interface                                     | USB 1.1   |   |
| Power   | AC 100 to 240 V 50/60 Hz 25 VA (using included AC adapter)  |   |
| Operation temperature/<br>humidity range (*1) | 13 to 33°C, relative humidity 80% or less (at 33°C) with no condensation  |   |
| Storage temperature/<br>humidity range        | 0 to 40°C, relative humidity 80% or less (at 35°C) with no condensation   |   |
| Size (W x H x D)                              | 271 x 274 x 500 mm (10-11/16 x 10-3/4 x 19-11/16 in.)   |   |
| Weight  | 18 kg (39.7 lb.)  |   |

\*1 Operating temperature/humidity range of products for North America : 13 to 33°C, relative humidity 80% or less (at 31°C) with no condensation

The specifications and drawings given here are subject to change without prior notice.



**< CAUTION >**

KONICA MINOLTA WILL NOT BE LIABLE FOR ANY DAMAGES RESULTING FROM THE MISUSE, MISHANDLING, UNAUTHORIZED MODIFICATION, ETC. OF THIS PRODUCT, OR FOR ANY INDIRECT OR INCIDENTAL DAMAGES (INCLUDING BUT NOT LIMITED TO LOSS OF BUSINESS PROFITS, INTERRUPTION OF BUSINESS, ETC.) DUE TO THE USE OF OR INABILITY TO USE THIS PRODUCT.



KONICA MINOLTA