



KONICA MINOLTA

Spectrophotometer **CM-25cG**



New standard model for color and gloss measurement!



A two-in-one model for color and gloss

The CM-25cG measures both color and gloss with a single press of the measuring button. This greatly improves work efficiency by eliminating the need to switch between two instruments - one for color, one for gloss - for each measurement, thus reducing takt time, and providing color and gloss data from exactly the same measurement point for more accurate quality control.

Changeable apertures allow easy measurements of small objects.

Color: Ø8 mm/ Ø3 mm

Gloss: Ø10 mm/ Ø3 mm

High inter-instrument agreement

The CM-25cG offers high inter-instrument agreement of within ΔE^* 0.15 (typical) (MAV) for color and ± 0.2 GU for gloss measurements of 1 to 10 GU. This high inter-instrument agreement enables digital color communication for more efficient quality control among your factories or between your company and your partners.



High repeatability and user friendliness

By using a 45°:c:0° illumination/viewing system with ring-shaped illumination having light sources radially located at certain intervals, the CM-25cG provides stable data while minimizing instrument rotational effects. The system also provides data with high accuracy and repeatability even if there is a small gap between the measurement aperture and the subject.

Other features include high-speed measurement, cable-free operation, and viewing ports and measuring buttons on both the right and left sides of the instrument body for easy operation and high measurement stability in any situation.

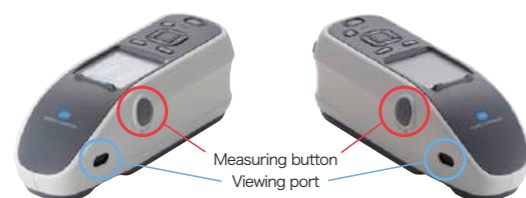

*Level of subject visibility through viewing port depends on measurement subject.



<NEW> Enhanced work efficiency improvement function

✓Standard color automatic selection function

When this function is set, the optimum target color candidates for comparison from among the target colors registered in advance are automatically displayed after sample measurement. This makes it easy to determine the appropriate target color.

Even when various colors are measured in the inspection process in the automobile industry, etc., there is no need to manually reset the target color before measurement. The target color can be easily selected from the candidates displayed after measurement.

This function can shorten the inspection time.



✓Job function

You can set the work procedure according to the inspection work flow on your device by using the optional SpectraMagic NX2. For example, by registering the measurement part and measurement procedure on the device together with the explanatory image, the operator can perform the work according to the procedure displayed on the device. It is especially effective for repeated measurement work for inspection.

Spectrophotometer Configuration Tool CM-CT1 Ver.1.5 or later

The CM-CT1 gives manufacturers the means for easily and quickly setting up the CM-25cG spectrophotometers. Moreover, when multiple devices are used or when the same conditions need to be set amongst multiple factories or suppliers, settings can be compiled into a file and shared. Setting of User Index*1 has been added.

*1: Function is available only with a valid activated SpectraMagic NX2 dongle or dongle-less license.

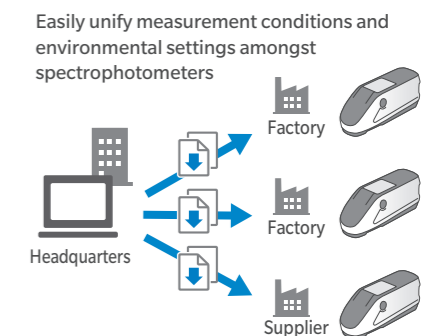
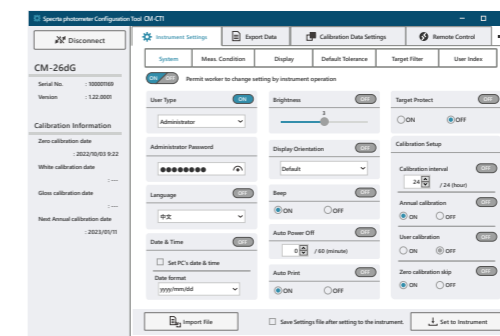

- OS: Windows® 10 Pro 64 bit Version 1903 or higher / Windows® 11 Pro
- CPU: 2.0 GHz equivalent or faster
- Memory: 2 GB or more
- Hard disk: 10 GB or more of free space for installation
- Other: USB port (For connecting to spectrophotometers and SpectraMagic NX2 dongle)
- Windows® is a trademark or registered trademark of Microsoft Corporation in the USA and other countries.

Option Color Data Software SpectraMagic NX2

SpectraMagic NX2 is color management software that gives users a customizable screen display and a wide range of functions for operating and configuring their spectrophotometers or Chroma Meter from a computer. Users can display data lists and create color difference graphs and spectral graphs to assist in color management that requires judgment based on numerous values and indicators.

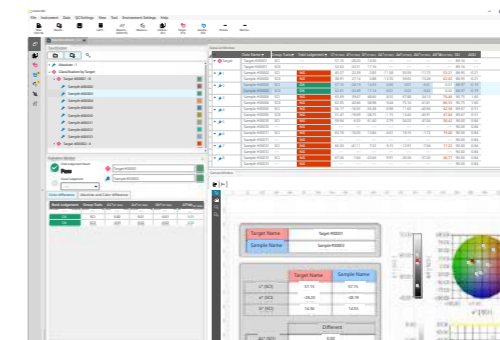

You can see the details in the catalog from the following 2D code. →



SpectraMagic NX2 web Site

Main Specifications

Model	Spectrophotometer CM-25cG		
Illumination/viewing system	45°c:0° Conforms to CIE No. 15 (2004), ISO 7724/1, ASTM E179, ASTM E1164, DIN 5033 Teil7, JIS Z8722 Condition "a"		
Detector	Dual 40-element silicon photodiode arrays		
Spectral separation device	Planar diffraction grating		
Wavelength range	360 to 740 nm		
Wavelength pitch	10 nm		
Half bandwidth	Approx. 10 nm		
Measurement range	0 to 175 %; Resolution : 0.01 %		
Light source	Pulsed xenon lamp		
Measurement/illumination area	MAV: Ø8 mm/12×16 mm, SAV: Ø3 mm/12×16 mm		
Color	Repeatability	Standard deviation within ΔE*ab 0.04 (When a white calibration plate is measured 30 times at 10-second intervals after white calibration under Konica Minolta standard conditions)	
	Inter-instrument agreement	Within ΔE*ab 0.15 (MAV) (Average for 12 BCRA Series II color tiles compared to values measured with a master body under Konica Minolta standard conditions)	
	Observer	2° Standard Observer, 10° Standard Observer	
	Illuminant	A, C, D50, D65, F2, F6, F7, F8, F10, F11, F12, D50, D65, User illuminant *1 (simultaneous evaluation with two illuminants possible)	
	Display items	Spectral values/graph, colorimetric values/graph, color-difference values/graph, pass/fail judgement, pseudocolor	
Color spaces	L*a*b*, L*c*h, Hunter Lab, Yxy, XYZ, and color differences in these spaces; Munsell		
Indexes	MI, WI (ASTM E313-73), YI (ASTM E313-73, ASTM D1925), ISO Brightness (ISO2470), WI/Tint (CIE), User Index*2		
Color-difference equations	ΔE*ab (CIE 1976), ΔE*94 (CIE 1994), ΔE00 (CIEDE2000), CMC (l:c), ΔE (Hunter), ΔE99a (DIN 99a)		
Gloss	Measurement geometry	60°	
	Light source	White LED	
	Detector	Silicon photo diode	
	Color sensitivity	Spectrally adjusted to CIE photopic luminous efficiency V(λ) under CIE illuminant C	
	Measurement range	0 to 200 GU; Output/display resolution : 0.01 GU	
	Measurement area	MAV: Ø10 mm, SAV: Ø3 mm	
	Repeatability	Standard deviation	0 to 10 GU: Within 0.1 GU 10 to 100 GU: Within 0.2 GU 100 to 200 GU: Within 0.2%
		(When measured 30 times at 10-second intervals under Konica Minolta standard measurement conditions)	
	Inter-instrument agreement	0 to 10 GU: Within ± 0.2 GU 10 to 100 GU: Within ± 0.5 GU (MAV: compared to values measured with a master body under Konica Minolta standard measurement conditions)	
	Standard compliance	JIS Z8741, JIS K5600, ISO 2813, ISO 7668, ASTM D523-08, ASTM D2457-13, DIN 67530	
	Measurement time	Approx. 1 seconds (to data display/output)	
	Minimum measurement interval	Approx. 2 seconds	
Battery performance	Approx. 3,000 measurements (approx. 1,000 measurements when using WLAN/Bluetooth) when measurements are taken at 10-second intervals at 23°C with the dedicated lithium battery		
Displayed languages	Japanese, English, German, French, Italian, Spanish, Chinese (Simplified), Portuguese, Russian, Turkish, Polish		
Display	2.7-inch TFT color LCD		
Interfaces	USB 2.0; Bluetooth (SPP-compatible)* WLAN (802.11 a/b/g/n)* *Optional WLAN/Bluetooth module required		
	WLAN security supports WPA2-PSK (WPA2-Personal) and WPA-PSK (WPA-Personal) for the AdHoc method, and WPA3-PSK (WPA3-Personal), WPA2-PSK (WPA2-Personal) and WPA-PSK (WPA-Personal) for the Infrastructure method.		
Data memory	Target data: 2,500 measurements; Sample data: 7,500 measurements		
Power	Dedicated lithium-ion battery (removable), USB bus power (with lithium-ion battery installed), Special AC adapter (with lithium-ion battery installed)		
Charging time	Approx. 6 hours when no charge remains		
Operation temperature/humidity range	5 to 40 °C, relative humidity is 80% or less (at 35°C) with no condensation		
Storage temperature/humidity range	0 to 45 °C, relative humidity is 80% or less (at 35°C) with no condensation		
Size (W x H x D)	Approx. 81 x 81 x 224 mm		
Weight	Approx. 600 g (including battery)		

*1 Optional Color Data Software SpectraMagic NX2 Pro is required to use UV Adjusted setting.

*2 Spectrophotometer Configuration Tool CM-CT1 (Ver. 1.4 or later) and Color Data Software SpectraMagic NX2 is required for setting user indexes.

System Diagram

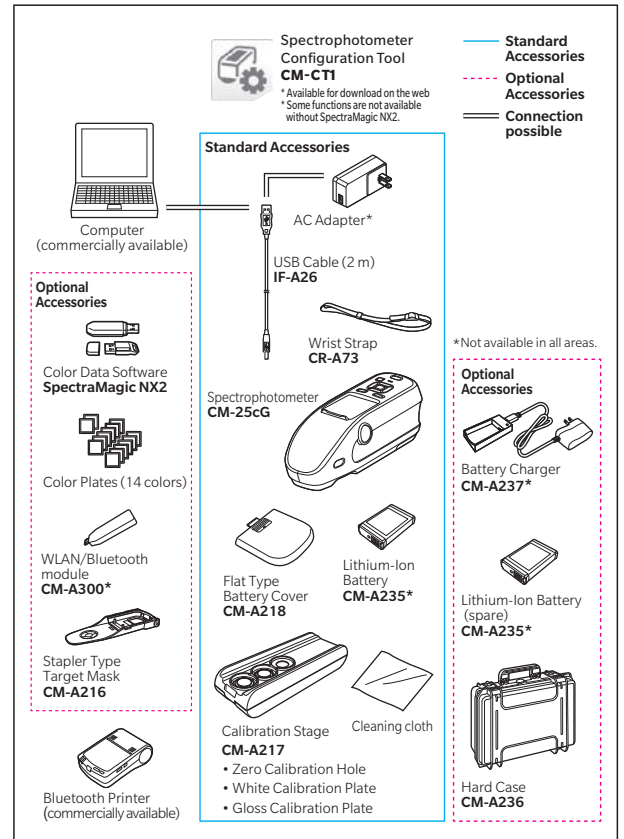

Dimensions (Units: mm)

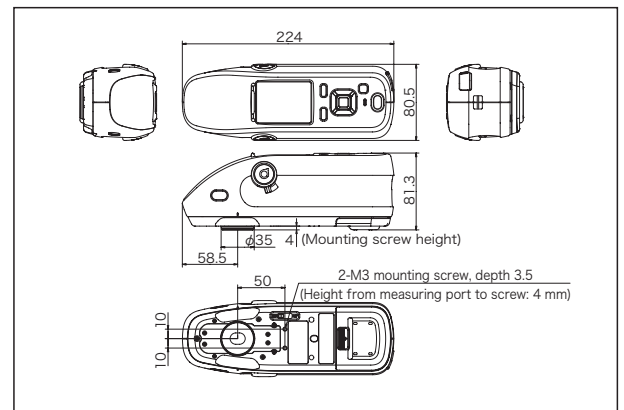

- KONICA MINOLTA, the Konica Minolta logo and symbol mark, "Giving Shape to Ideas" and SpectraMagic are registered trademarks or trademarks of Konica Minolta, Inc.
- Bluetooth® is a registered trademark of Bluetooth SIG, Inc. and is used under license agreement.
- Displays shown are for illustration purpose only.
- The specifications and appearance shown herein are subject to change without notice.



SAFETY PRECAUTIONS

For correct use and for your safety, be sure to read the instruction manual before using the instrument.

- Always connect the instrument to the specified power supply voltage. Improper connection may cause a fire or electric shock.
- Be sure to use the specified batteries. Using improper batteries may cause a fire or electric shock.



JQA-QMA15888
Design, development, manufacture/
manufacturing management, calibration, and
service of measuring instruments.



JQA-E-80027
Design, development, manufacture, service and sales
of measuring instruments.

KONICA MINOLTA, INC.	Osaka, Japan	PHONE: (888)473-2656 (in USA), +1(201)236-4300 (outside USA)	FAX: +1(201)785-2480	E-Mail: service.us@konicaminolta.com
Konica Minolta Sensing Americas, Inc.	New Jersey, U.S.A.			
Konica Minolta Sensing Europe B.V.	European HQ / BENELUX	Nieuwegein, Netherlands	PHONE: +31(0)30 248-1193	E-Mail: info.benelux@seu.konicaminolta.eu
	German Office	München, Germany	PHONE: +49(0)89 4357 156 0	E-Mail: info.germany@seu.konicaminolta.eu
	French Office	Roissy CDG Cedex, France	PHONE: +33(0)1 80 11 10 70	E-Mail: info.france@seu.konicaminolta.eu
	UK Office	Warrington, United Kingdom	PHONE: +44(0)1925 467300	E-Mail: info.uk@seu.konicaminolta.eu
	Italian Office	Cinisello Balsamo, Italy	PHONE: +39 02849488.00	E-Mail: info.italy@seu.konicaminolta.eu
	Swiss Office	Dietikon, Switzerland	PHONE: +41(0)43 322-9800	E-Mail: info.switzerland@seu.konicaminolta.eu
	Nordic Office	VÄSTRA FRÖLUNDA, Sweden	PHONE: +46(0)31 7099464	E-Mail: info.nordic@seu.konicaminolta.eu
Polish Office	Wroclaw, Poland	PHONE: +48(0)71 73452-11	E-Mail: info.poland@seu.konicaminolta.eu	
Konica Minolta (CHINA) Investment Ltd.	SE Sales Division	Shanghai, China	PHONE: +86-(0)21-6057-1089	E-Mail: hcn_sensing@gcp.konicaminolta.com
	Beijing Office	Beijing, China	PHONE: +86-(0)10-8522 1551	E-Mail: hcn_sensing@gcp.konicaminolta.com
	Guangzhou Office	Guangzhou, China	PHONE: +86-(0)20-3826 4220	E-Mail: hcn_sensing@gcp.konicaminolta.com
	Chongqing Office	Chongqing, China	PHONE: +86-(0)23-6773 4988	E-Mail: hcn_sensing@gcp.konicaminolta.com
	Qingdao Office	Shandong, China	PHONE: +86-(0)532-8079 1871	E-Mail: hcn_sensing@gcp.konicaminolta.com
	Wuhan Office	Hubei, China	PHONE: +86-(0)27-6885 0586	E-Mail: hcn_sensing@gcp.konicaminolta.com
	Shenzhen Office	Shenzhen, China	PHONE: +86-(0)755-2868 7535	E-Mail: hcn_sensing@gcp.konicaminolta.com
Xiamen Office	Xiamen, China	PHONE: +86-(0)592-7107 399	E-Mail: hcn_sensing@gcp.konicaminolta.com	
Konica Minolta Sensing Singapore Pte. Ltd.	Singapore	PHONE: +65 6563-5533	E-Mail: se-service.sg@konicaminolta.com	
Konica Minolta Sensing Korea Co., Ltd.	Korean HQ	Goyang-si, Korea	PHONE: +82(0)2-523-9726	E-Mail: se.korea@konicaminolta.com
	Cheonan Office	Cheonan-si, Korea	PHONE: +82(0)41-556-9726	E-Mail: se.korea@konicaminolta.com

Addresses and telephone/fax numbers and e-mail address are subject to change without notice.
For the latest contact information, please refer to KONICA MINOLTA Worldwide Offices web page:

<https://konicaminolta.com/instruments/network>