



KONICA MINOLTA

Spectrodensitometer **FD-7 / FD-5**

14

3-in-1 next-generation measurement tool

Color

Density

Illumination

**Streamlines color adjustment in printing,
even on substrates with fluorescent
whitening agents**



A high-accuracy, compact, lightweight, handheld, next-generation spectrodensitometer that measures color, density, and illumination* for applications from R&D to quality control. *FD-7 only

Color

The world's first measuring instrument that corresponds to Measurement Condition M1 of ISO 13655

- Konica Minolta's original VFS (Virtual Fluorescence Standard) technology enables L*a*b* measurements corresponding to ISO 13655 Measurement Condition M1.
- The FD-7 and FD-5 can take measurements corresponding to all four of the ISO 13655 Measurement Conditions. Measurements corresponding to M1 are enabled by Konica Minolta's original VFS (Virtual Fluorescence Standard) technology, and measurements corresponding to M0 (CIE Illuminant A) and M2 (illumination with UV-cut filter) can also be taken. In addition, by attaching the included polarization filter, measurements corresponding to M3 (M2+ polarization filter) can be taken.

Scan measurements can be performed. (FD-7 only)

- Manual scan measurements can be performed when the instrument is connected to a PC.
- With optional software basIColor catch all, the colorimetric values, density values, and spectral reflectance values of various test charts (MediaWedge ECI2002, IT8.7/3, etc.) can be measured in a single operation.

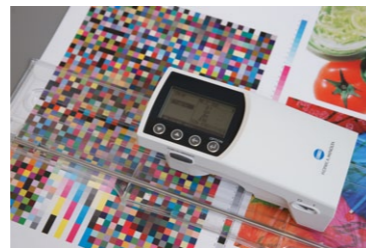

Spectral output (FD-7 only)

- When the FD-7 is connected to a computer, the spectral reflectance data (380 to 730 nm) of samples under various illuminants and the spectral irradiance data (360 to 730 nm) of the environmental lighting can be measured and output to a computer. This makes the FD-7 ideal for research and development applications.

Illumination

Illumination environment light can be measured. (FD-7 only)

- The illuminance and color temperature in a color viewing cabinet or the actual ambient light under which printed materials will be evaluated can be measured.

Measured environmental light can be set as illumination light source (user illuminant)

- In the past, when measuring printed materials containing fluorescent whitening agents (FWA), large differences between measured values and visual evaluation sometimes occurred. But with the FD-7, colorimetric values can be calculated under the measured environmental light source, providing results which more closely correspond to on-site visual evaluation. This ensures customers receive the colors they want and eliminates time and labor lost resolving customer complaints due to the effects of FWA or metamerism.

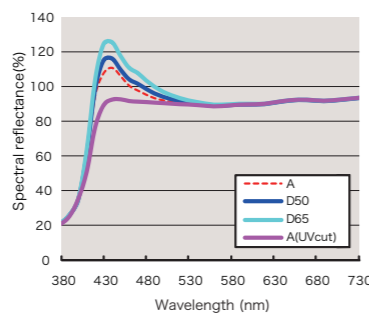
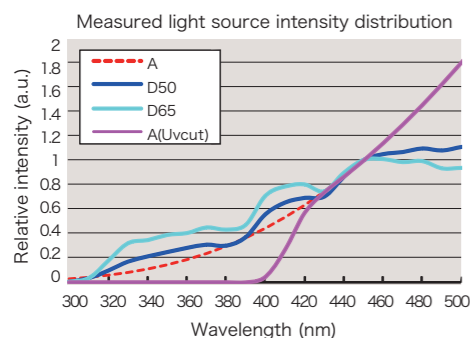

By measuring the environmental light source with an FD-7 master body and then transferring the user illuminant data to multiple FD-5 or FD-7 working bodies, color control using the same illumination light source at multiple locations can be achieved. In addition, the automatic wavelength compensation function minimizes inter-instrument errors when using multiple instruments.

FD-5
(Working body)



FD-5
(Working body)



FD-7
(Master body)



Data Management Software FD-S1w (included as standard accessory)

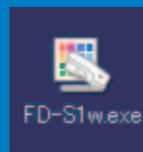

Features:

- Transfer of measurement data to Excel® sheet.
- Reading/registration of user illuminant data to/and storage as PC file
- Color set management functions (for instrument and Target Match functions)**2

System Requirements

- OS** Windows XP, Windows Vista or Windows 7; 32-bit or 64-bit versions
- Excel** Excel 2003 (Windows XP), Excel 2007 (Windows Vista), or Excel 2010 (32-bit version; Windows 7)
- The hardware or the computer system to be used must meet or exceed the recommended system requirements for the compatible OS and Excel version being used.

- Compatible Instruments** Spectrodensitometer FD-7, FD-5
- Display language** English, Japanese, Chinese (Simplified) (Select one during installation.)

Density

Printing quality control functions including trapping, dot gain, etc.

- A new industry-standard tool for commercial printing and packaging printing to improve productivity and quality at low cost.

- CMYK density • Dot area • Dot gain • Trapping • Simple density difference
- PS plate dot area • PS plate dot gain • Spot color density

Improvements in quality control functions to meet more advanced needs at printing locations.



Target Match function**2

- Displays the color difference from the target color and the process color or spot color density adjustment needed to bring the measured color closer to the target color. By using the Target Match function, ink color adjustment can be performed without a computer or special software.
- Ideal for spot colors or process colors.
- Displays color difference and density.
- Displays estimated density adjustment needed to bring the measured color closer to the target color and the predicted color difference after adjustment.

Measure color difference. Result: Adjusting the density of spot color with 400 nm peak absorbance from 0.86 to 1.16 is predicted to result in a color difference of 0.48.

TARGETMATCH	M1 2' D50	
<input checked="" type="checkbox"/> Paper	ΔD(400)	+0.30 D
<input checked="" type="checkbox"/> Target	ΔE*94	
<input checked="" type="checkbox"/> Sample	2.54 @ 0.86 D	
	>> 0.48 @ 1.16 D	
Measure sample		

Functions corresponding to various printing standards

- Pass/fail judgment against ISO, JapanColor, GRACoL®/SWOP®, PSO, or user-defined custom targets can be performed. The FD-7 and FD-5 are ideal for on-site printing quality control.
- ISO 12647 check**2
Color difference, TVI, and mid-tone spread can be evaluated.
- Gray balance
Gray balance can be evaluated using the G7® evaluation method.

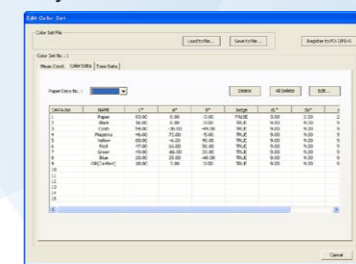

ISO CHECK	M1 2' D50	
<input checked="" type="checkbox"/> Yellow40%	ΔL*	-0.32
<input checked="" type="checkbox"/> Red	Δa*	0.08
<input checked="" type="checkbox"/> Green	Δb*	-0.22
<input type="checkbox"/> Blue	ΔE*ab	0.40
	16/21	CS01 : PT1-AM-BB
Red : Pass		

*1 Target colors (color sets) must be set using the included FD Data Management Software FD-S1w.
*2 Backing conversion function converts the target values to enable evaluation even when backing conditions for samples do not match those of the targets.

Industry's first automatic wavelength compensation function

- Wavelength compensation is performed during white calibration^{*3} without requiring additional work.
- Until now, wavelength compensation could only be carried out as one part of manufacturer servicing. This task is now performed whenever white calibration^{*3} is done, helping to maintain the high reliability of measurement values until the next periodic servicing.

*3 Except when polarization filter is attached.

World's lightest^{*4}

- The main body weighs only about 350g, and even with the target mask attached it's only about 430g, lighter than any previous spectrophotometer.
- This reduces the load on the user's arm during work, improving efficiency when taking measurements over a long time.

*4 Display-equipped spectrophotometer. As of December 1, 2012

Worry-free after-sales service

- Worldwide service centers provide rapid support when needed.
- A comprehensive service network is in place to ensure that your instrument is always in top shape.

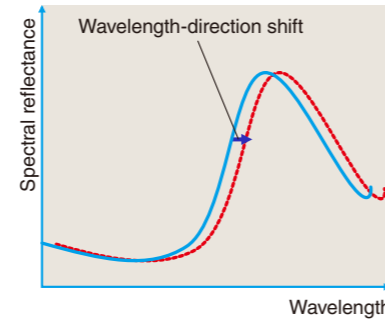

System Diagram

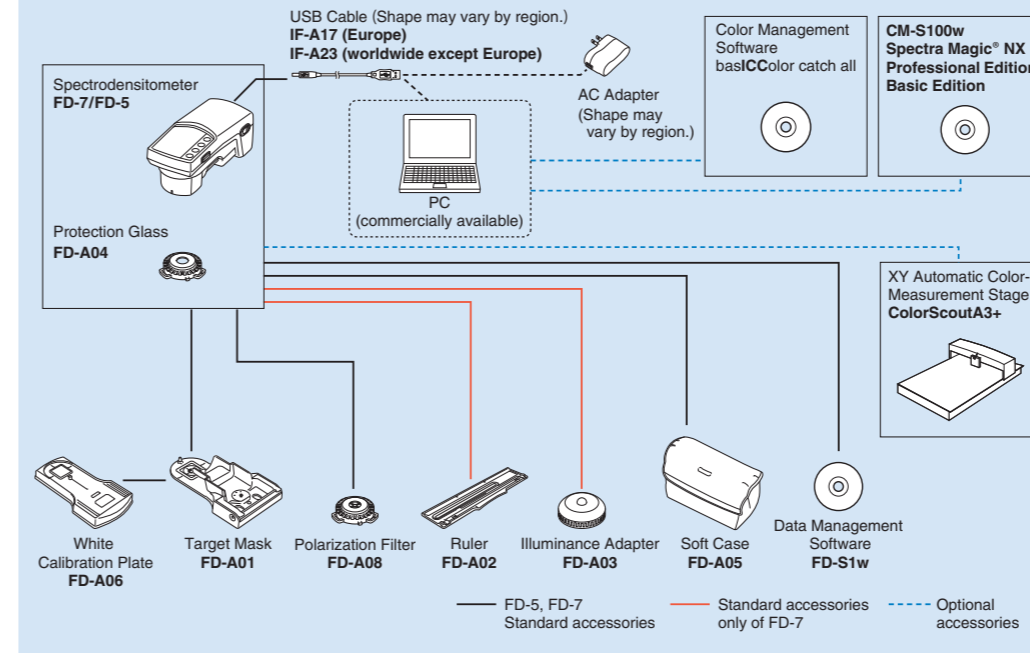

Dimensions (Units: mm)

With removable target mask attached

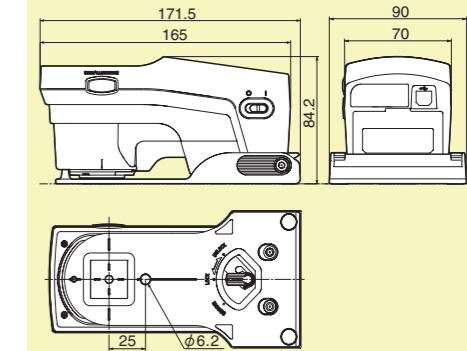

Optional accessories

XY Automatic Color-Measurement Stage ColorScout series^{*5}

The ColorScout series enables accurate, high-efficiency measurements of color charts with the Spectrophotometer FD-7 and FD-5. It enables automatic positioning and measurement of the instrument, providing higher repeatability and reducing labor compared to manual measurements.

XY automatic color-measurement stage
Backing sheet available as either white surface or black surface.

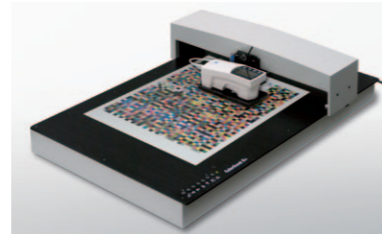

Capable of both spot and scan measurements!

- Supports A3+ and A4+ sizes. Measurements can be efficiently done without cutting, folding and switching in and out important color charts
- Definitions files can be easily created for charts using the ClrChrt application that comes standard with the product.
- Data can be saved in ANSI8.7 or CGATS.5 format and exported to profile editing software. Colors can be reproduced closer to what is perceived with the human eye, by using M1 light sources or user-defined light sources.
- The ES series uses electrostatic attraction to immobilize charts during measurement.

ClrChrt software (Included)

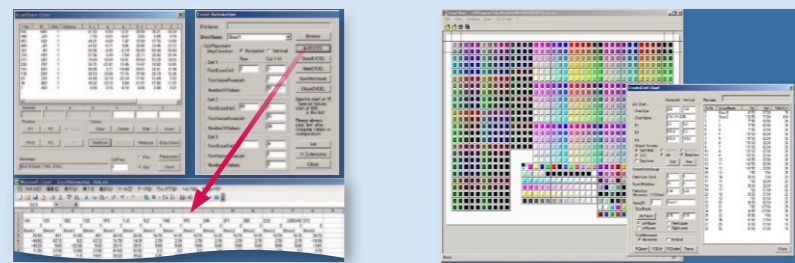

Measurement data

Chart design screen

Specification	ColorScout A3+	ColorScout A3+ ES	ColorScout A4+ ES
Electrostatic attraction	—	✓	✓
Measurable sizes	320 x 460 mm	320 x 460 mm	320 x 230 mm
Sample thickness	Max 1.5 mm	Max 1.0 mm	Max 1.0 mm

ColorChart minimum computing requirements	
OS; CPU	Windows® XP(32-bit), Windows® 7(32-bit, 64-bit); 300MHz or faster
Hard disk; Memory	30MB or more available disk space; 64MB or more

Color Management Software basIColor series^{*5}

The software contains interfaces for all models of the FD series and enables users to handle everything from measuring colors to creating, analyzing and managing the quality (pass/fail judgment) of ICC profiles.

For major efficiency increases in daily color control work.

- Enables color measurement, ICC profile creation, and quality control (pass/fail evaluation and certification).
- Incorporates a variety of profile evaluation functions, such as tone curves for 2D/3D color gamuts and ΔE comparison and display, and supports functions that improve profile quality (measurement data smoothing, duplicate patch correction, defect [measured value] correction).
- Enables profile creation with multi-channel data (seven colors at most) having more colors than CMYK full color as well as normal measurement and normal profile creation.
- Supports device link profile creation, editing, and evaluation. Can automatically create and output PDF reports.

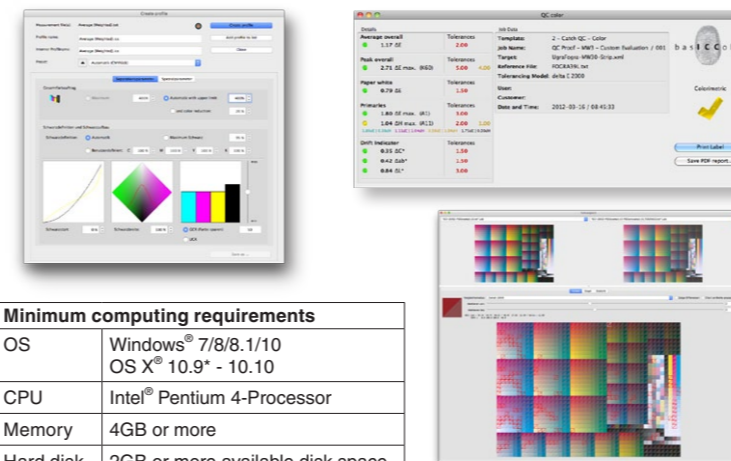

Minimum computing requirements	
OS	Windows® 7/8/8.1/10 OS X® 10.9* - 10.10
CPU	Intel® Pentium 4-Processor
Memory	4GB or more
Hard disk	2GB or more available disk space

* basIColor Print requires OS X® 10.9.5 or above.

Color Data Software SpectraMagic® NX^{*5}

Ideal for color-difference control of spot colors relative to target colors.

Achieves overall ease of use with free selection of evaluation equations and report formatting.

With the new E*₉₄ and E₀₀ color difference equations as well as a user index that allows users to freely set their own evaluation equations, SpectraMagic® NX can meet a wide variety of user needs.

Measurement data can be displayed in list form or in objects such as spectral graphs, color-difference graphs, etc. that the user can freely lay out, and those objects can be copied and pasted as is into other software such as Excel® for easy data control. In addition, printing screens can also be designed using the same objects to create user-defined formats for easy-to-read reports.

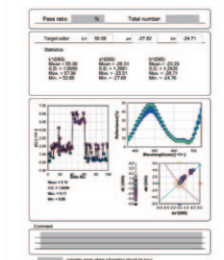

Printing screen

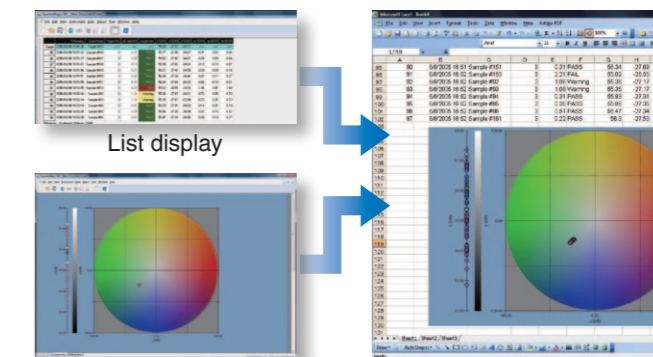

List display

Color-difference graph object

Pasted into Excel®

Minimum Computing Requirements	
OS	Windows® Vista business 32-bit, 64-bit; Windows® 7 Professional 32-bit, 64-bit; Windows® 8.1 Pro 32-bit, 64-bit; Windows® 10 Pro 32-bit, 64-bit (English, Japanese, German, French, Spanish, Italian, Traditional Chinese, Simplified Chinese, Portuguese, and Hangul versions) • The hardware of the computer system to be used must meet or exceed the greater of the recommended system requirements for the compatible OS being used or the following specifications.
CPU	Pentium® III 600 MHz or higher (recommended)
Memory	128 MB (256 MB recommended)
Hard disk	450 MB of available disk space (At least 400 MB of available space is required in the system drive.)

*5 Measurements with polarization filter attached cannot be performed.

Function

	FD-7	FD-5
Density measurement functions		
Density, density difference	●	●
Dot area	●	●
Dot gain	●	●
Trapping	●	●
PS plate dot area	●	●
PS plate dot gain	●	●
Spot color density	●	●
Gray balance	●	●
Midtone spread	●	●
ISO 12647 check	●	●
Target match	●	●
Colorimetric measurement functions		
L*a*b*	●	●
L*C*h	●	●
Hunter Lab	●	●
Yxy	●	●
XYZ	●	●
ΔE^*_{ab} (CIE1976)	●	●
ΔE^*_{94} (CIE1994)	●	●
ΔE_{00} (CIE2000)	●	●
ΔE (Hunter)	●	●
CMC (l:c)	●	●
Illuminance measurement functions		
Illuminance	●	
Correlated color temperature	●	
Paper index		
WI/Tint (ASTME313-96)	●	●
ISO Brightness (ISO2470-1)	●	●
D ₆₅ Brightness (ISO2470-2)	●	●
Fluorescence index	●	●
Spectral reflectance		
Spectral data output	●	
Memory		
Target density	30	30
Target color	30	30
Color sets of 15 colors each*1	50	50
Other functions		
Manual scan*2	●	
Automatic function (density, dot area, color)	●	●
PASS/FAIL judgment	●	●
Software		
basICColor series	●	●
FD-S1w	●	●
SpectraMagic NX	●	●
ClrChrt (Included with ColorScout series)	●	●

Main specifications

Illumination/viewing system	45°a: 0°(annular illumination)*3 Conforms to CIE No. 15, ISO 7724/1, DIN5033 Teil 7, ASTM E 1164, and JIS Z 8722 Condition a for reflectance measurements.
Spectral separation device	Concave grating
Wavelength range	Spectral reflectance: 380 to 730 nm; Spectral irradiance (FD-7 only): 360 to 730 nm
Wavelength pitch	10 nm
Half bandwidth	Approx. 10 nm
Measurement area	Ø3.5 mm
Light source	LED
Measurement range	Density: 0.0D to 2.5D; Reflectance: 0 to 150%
Short-term repeatability	Density: $\sigma 0.01D$ Without polarization filter : 0.0D ~ 2.5D, Yellow 0.0D ~ 2.0D With polarization filter : 0.0D ~ 2.5D, Yellow 0.0D ~ 1.8D (When measurements taken 30 times at 10-second intervals after white calibration has been performed) Colorimetric: Within $\sigma \Delta E_{00} 0.05$ (Without polarization filter) (When white plate is measured 30 times at 10-second intervals after white calibration has been performed)
Inter-instrument agreement	Within $\Delta E_{00} 0.3$ (Average of 12 BCRA Series II color tiles compared to values measured with a master body under Konica Minolta standard conditions; without polarization filter)
Measurement time	Approx. 1.4 s (single-point reflectance measurement without polarization filter)
Measurement conditions	Corresponding to ISO 13655 Measurement Conditions M0 (CIE Illuminant A), M1 (CIE Illuminant D50), M2 (illumination with UV-cut filter), and M3 (M2 + polarization filter); User-defined illuminant
Illuminant	A, C, D50, D65, ID50, ID65, F2, F6, F7, F8, F9, F10, F11, F12, User-defined illuminant
Observer	2° or 10° Standard Observer
Density	ISO Status T, ISO Status E, ISO Status A, ISO Status I; DIN16536
Display language	English, French, German, Spanish, Japanese, Chinese (Simplified)
Interface	USB 2.0
Output data*2	Displayed values; Spectral reflectance data (FD-7 only); Spectral irradiance data (FD-7 only)
Power	Rechargeable internal lithium-ion battery (Number of measurements per charge: Approx. 2,000 when new without polarization filter); AC adapter; USB bus power
Size (W x D x H)	70 x 165 x 83 mm (Body only); 90 x 172 x 84 mm (With target mask attached)
Weight	Approx. 350 g (Body only); Approx. 430 g (With target mask attached)
Operation temperature/humidity range	10 to 35°C, 30 to 85% relative humidity with no condensation
Storage temperature/humidity range	0 to 45°C, 0 to 85% relative humidity with no condensation
Standard accessories	White Calibration Plate, Target Mask, Protection Glass, AC Adapter, USB Cable, Soft Case, Polarization Filter, Data Management Software FD-S1w, Illuminance Adapter (FD-7 only), Ruler (FD-7 only)
Optional accessories	Color Management Software basICColor series, XY Automatic Color Measurement Stage Color Scout series, Color Management Software SpectraMagic NX

*1 Used for ISO 12647 Check / Target match; Must be set using included FD-S1w software.

*2 Available when using PC software.

*3 Illumination for wavelengths under 400nm is unidirectional.

• Displays shown are for illustration purpose only.

• The specifications and appearance shown herein are subject to change without notice.

• KONICA MINOLTA, the Konica Minolta logo and symbol mark, "Giving Shape to Ideas" and SpectraMagic™ are registered trademarks or trademarks of KONICA MINOLTA, INC.

• The basICColor logo is a registered trademark of basICColor GmbH.

• Other company names and product names used herein are trademarks or registered trademarks of their respective companies.



SAFETY PRECAUTIONS

For correct use and for your safety, be sure to read the instruction manual before using the instrument.

- Always connect the instrument to the specified power supply voltage. Improper connection may cause a fire or electric shock.



Certificate No.: LRQ 0960094/A
Registration Date: March 3, 1995



Certificate No.: JOA-E-80027
Registration Date: March 12, 1997

KONICA MINOLTA, INC.
Konica Minolta Sensing Americas, Inc.
Konica Minolta Sensing Europe B.V.

Osaka, Japan
New Jersey, U.S.A.
European Headquarter / BENELUX
German Office
French Office
UK Office
Italian Office
Swiss Office
Nordic Office
Polish Office
Turkish Office
SE Sales Division
Beijing Office
Guangzhou Office
Chongqing Office
Qingdao Office
Wuhan Office

Konica Minolta (CHINA) Investment Ltd.

Konica Minolta Sensing Singapore Pte Ltd.
Konica Minolta Sensing Korea Co., Ltd.

Addresses and telephone/fax numbers are subject to change without notice. For the latest contact information, please refer to the KONICA MINOLTA Worldwide Offices web page :

©2010-2016 KONICA MINOLTA, INC.

Phone : 888-473-2656 (in USA), 201-236-4300 (outside USA)
Nieuwegein, Netherlands **Phone** : +31 (0)30 248-1193
München, Germany **Phone** : +49 (0)89 4357 156 0
Roissy CDG, France **Phone** : +33 (0)1 80 11 10 70
Warrington, United Kingdom **Phone** : +44 (0)1925 467300
Cinisello Balsamo, Italy **Phone** : +39 02849488.00
Dietikon, Switzerland **Phone** : +41 (0)43 322-9800
Västra Frölunda, Sweden **Phone** : +46 (0)31 7099464
Wroclaw, Poland **Phone** : +48 (0)71 73452-11
Istanbul, Turkey **Phone** : +90 (0) 216-528 56 56
Shanghai, China **Phone** : +86- (0)21-5489 0202
Beijing, China **Phone** : +86- (0)10-8522 1551
Guangdong, China **Phone** : +86- (0)20-3826 4220
Chongqing, China **Phone** : +86- (0)23-6773 4988
Shandong, China **Phone** : +86- (0)532-8079 1871
Hubei, China **Phone** : +86- (0)27-8544 9942
Singapore **Phone** : +65 6563-5533
Goyang-si, Korea **Phone** : +82 (0)2-523-9726

Fax : 201-785-2482
Fax : +31 (0)30 24 81 211
Fax : +49 (0)89 4357 156 99
Fax : +33 (0)1 80 11 10 82
Fax : +44 (0)1925 711143
Fax : +39 02849488.30
Fax : +41 (0)43 322-9809
Fax : +48 (0)71 734 52 10
Fax : +90 (0) 212-253 49 69
Fax : +86- (0)21-5489 0005
Fax : +86- (0)10-8522 1241
Fax : +86- (0)20-3826 4223
Fax : +86- (0)23-6773 4799
Fax : +86- (0)532-8079 1873
Fax : +86- (0)27-8544 9991
Fax : +65 6560-9721
Fax : +82 (0)31-995-6511

<http://konicaminolta.com/instruments/network>

9242-4897-10 BGMPK Printed in Japan